

3-TERMINAL 0.1A POSITIVE ADJUSTABLE REGULATOR

The FR317L/LF is adjustable 3-terminal positive voltage regulator capable of supplying in excess of 100mA over a 1.2V to 37V output range.

This is exceptionally easy to use and require only two external resistors to set the output voltage.

Further, it employ internal current limiting, thermal shutdown and safe area compensation.

FEATURES

- Adjustable output between 1.2V and 37V
- Guaranteed 100mA output current
- Line regulation typically 0.01%/V
- Load regulation typically 0.1%
- 80dB ripple rejection (with Cadj)
- Internal thermal overload protection
- Internal short-circuit current limiting
- Output transistor safe-area compensation

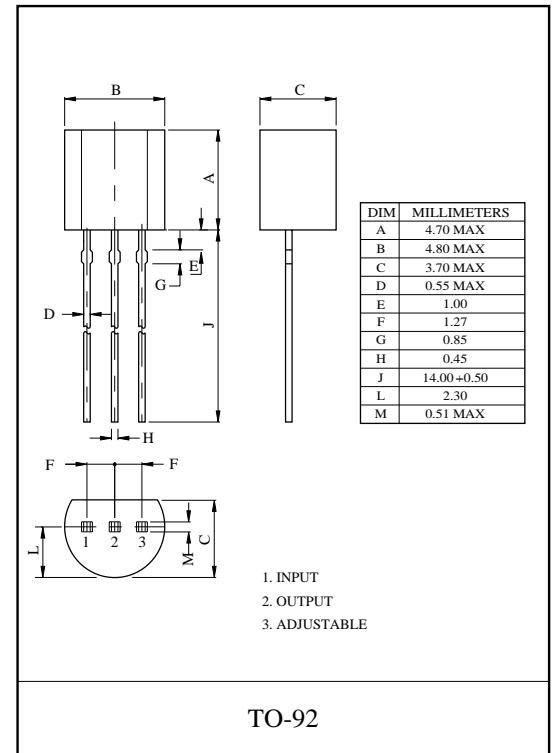

BLOCK DIAGRAM

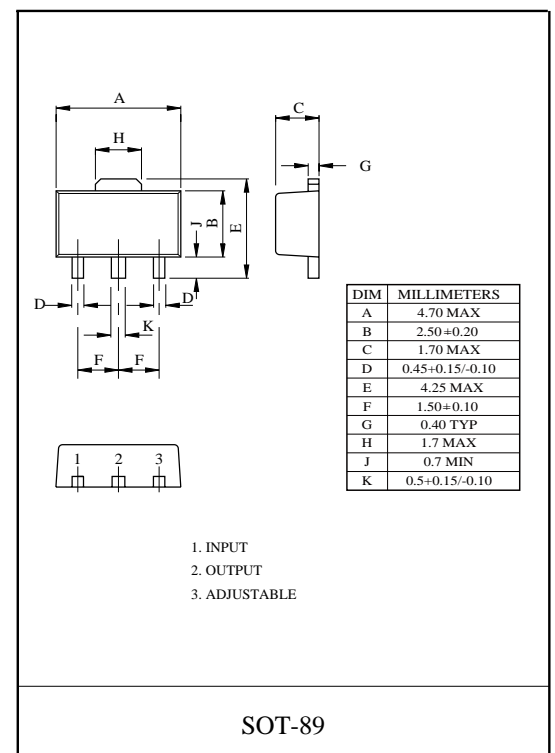
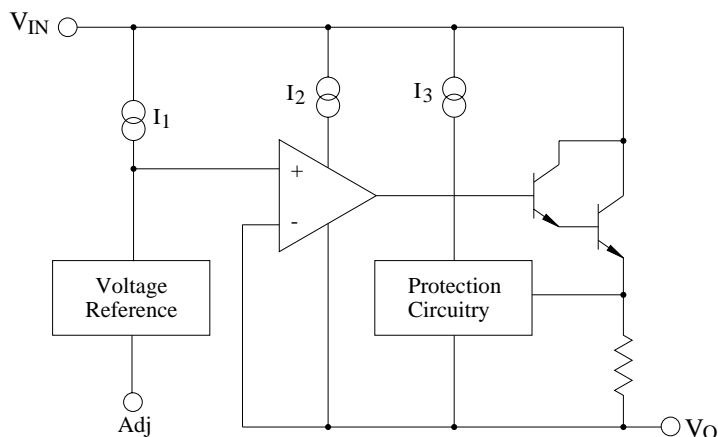



FR317L/LF

MAXIMUM RATINGS (Ta=25 °C)

CHARACTERISTIC	SYMBOL	RATING	UNIT
Input-Output Voltage Differential	$V_{IN} - V_{OUT}$	40	V
Power Dissipation (With infinite heat sink)	P_D	Internally limited	W
Operating Temperature	T_{opr}	-40 ~ 125	°C
Storage Temperature	T_{stg}	-65 ~ 150	°C

ELECTRICAL CHARACTERISTICS (Ta=25 °C)

($V_I - V_O = 3V$, $I_O = 40mA$, $-10^\circ C \leq T_j \leq 125^\circ C$, unless otherwise specified.)

CHARACTERISTIC	SYMBOL	TEST CONDITION	MIN.	TYP.	MAX.	UNIT
Line Regulation	$\Delta V_O(\text{Line})$	$3V \leq V_{IN} - V_{OUT} \leq 40V$	-	-	180	mV
Load Regulation	$\Delta V_O(\text{Load})$	$10mA \leq I_{OUT} \leq I_{MAX}$	-	-	10	mV
Adjustable Pin Current	I_{Adj}		10	-	100	μA
Adjustable Pin Current Change	ΔI_{Adj}	$10mA \leq I_O \leq I_{MAX}$, $3V \leq V_{IN} - V_{OUT} \leq 40V$	-	-	5	μA
Reference Voltage	V_{ref}	$10mA \leq I_O \leq I_{MAX}$, $3V \leq V_{IN} - V_{OUT} \leq 40V$, $P \leq P_{MAX}$	1.20	-	1.30	V
Minimum Load Current to Maintain Regulation	$I_{O(MIN)}$	$(V_{IN} - V_{OUT}) = 40V$	-	-	10	mA
Current Limit	$I_{O(MAX)}$	$(V_{IN} - V_{OUT}) = 3.0V$, $P \leq P_{MAX}$	0.1	-	0.3	A
		$(V_{IN} - V_{OUT}) = 40V$, $P \leq P_{MAX}$, $T_a = 25^\circ C$	0.025	-	0.15	A
Ripple Rejection Ratio	RR	$V_O = 10V$, $f = 120Hz$	66	-	-	dB

Note : Load and line regulation are specified at constant junction temperature.

Change in V_o due to heating effects must be taken into account separately. Pulse testing with low duty is used. ($P_{MAX} = 20W$)

TYPICAL APPLICATION (PROGRAMMABLE REGULATOR)

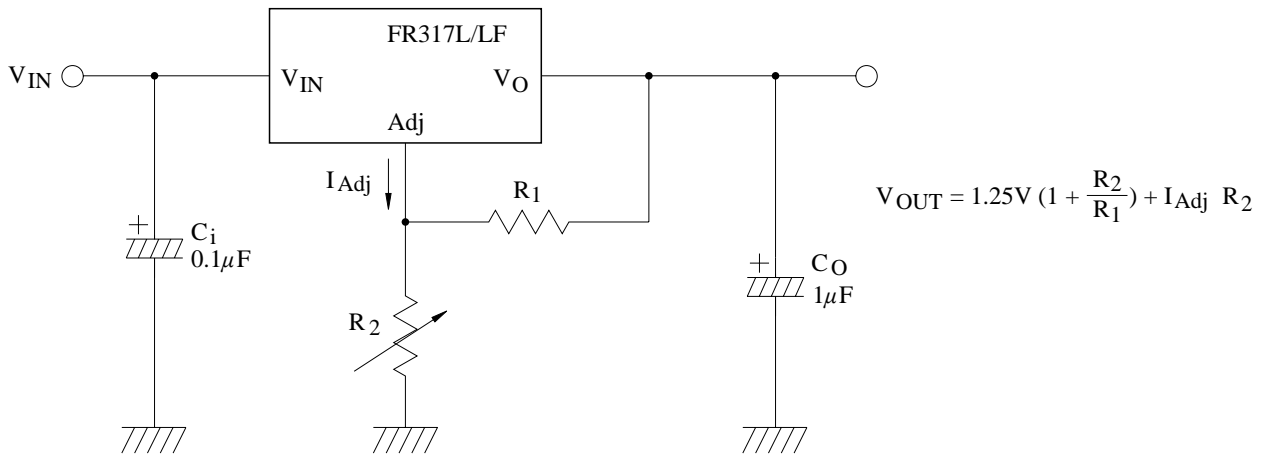

C_i is required when regulator is located an appreciable distance from power supply filter.

C_o is not needed for stability, however, in the range of $1\mu F$ to $100\mu F$ of aluminum or tantalum electrolytic are commonly used to provide improved output impedance and rejection of transients.

Since I_{Adj} is controlled to less than $100\mu A$, the error associated with this term is negligible in most applications.

Typical Characteristics Curves

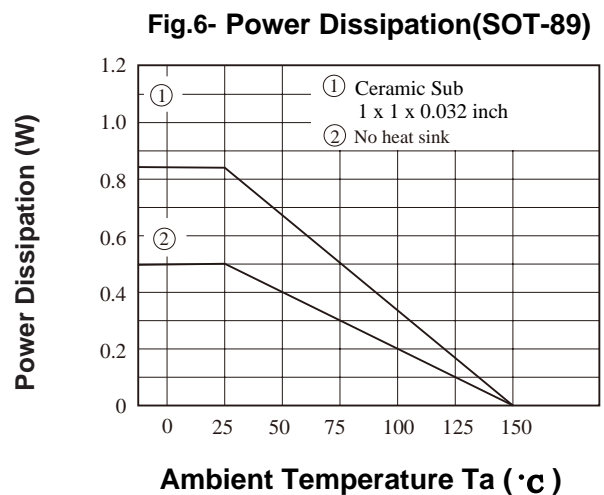
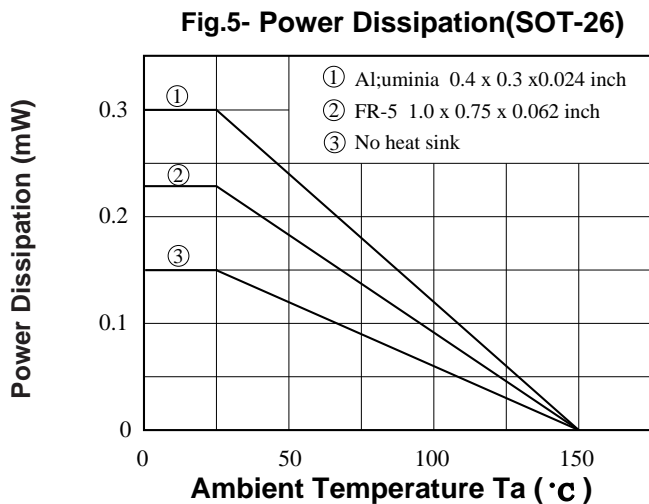
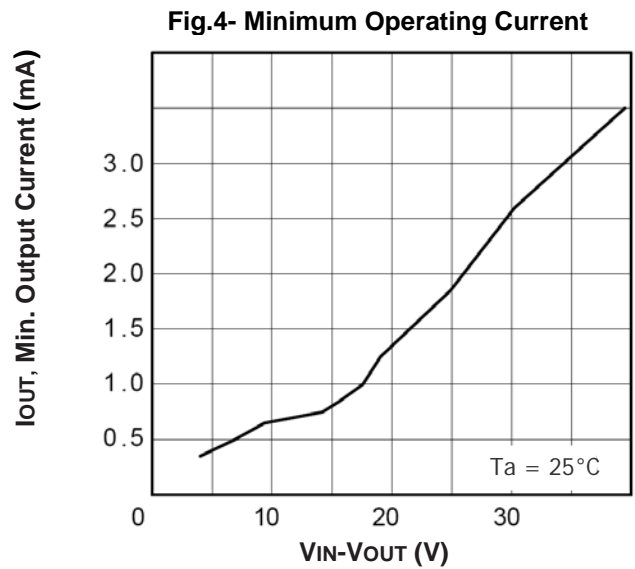
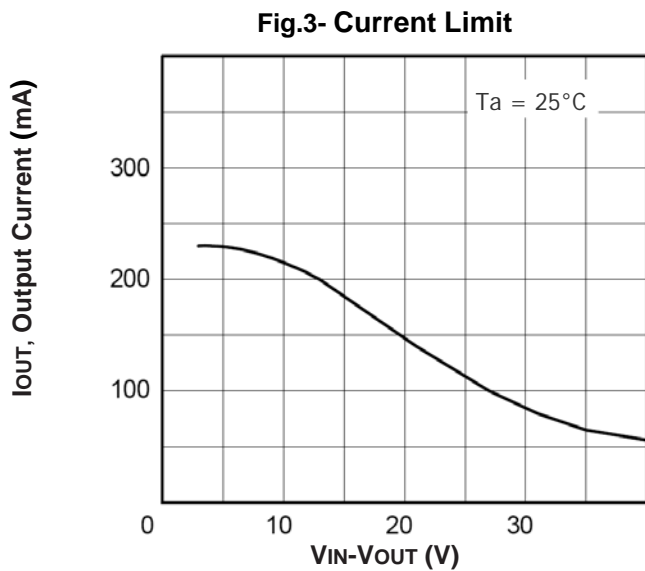
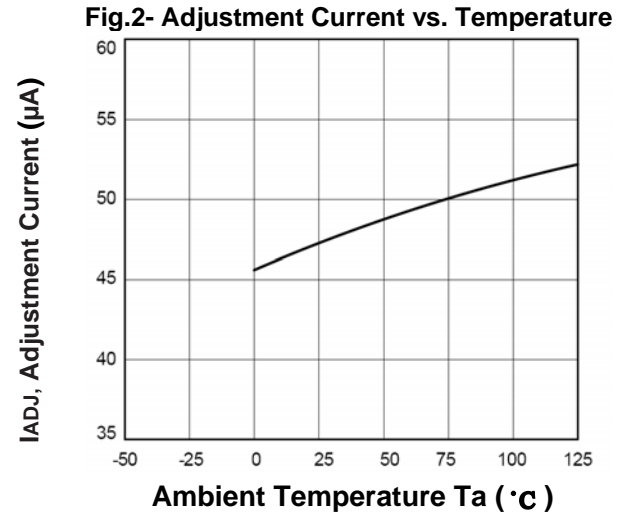
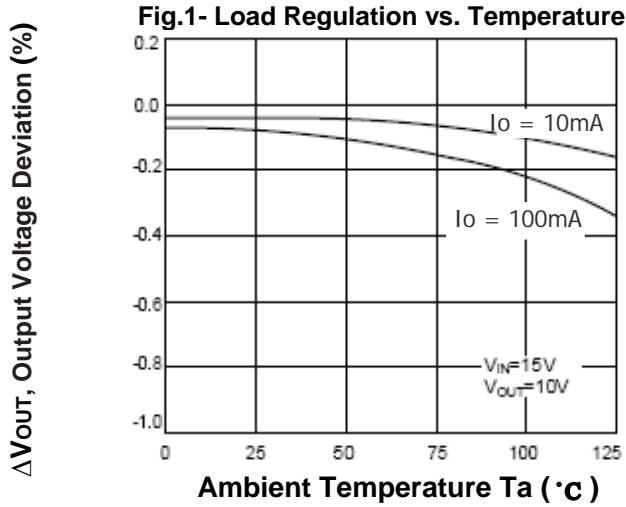

Soldering Methods

1. Storage environment: Temperature=10°C~35°C Humidity=65%±15%
2. Reflow soldering of surface-mount devices

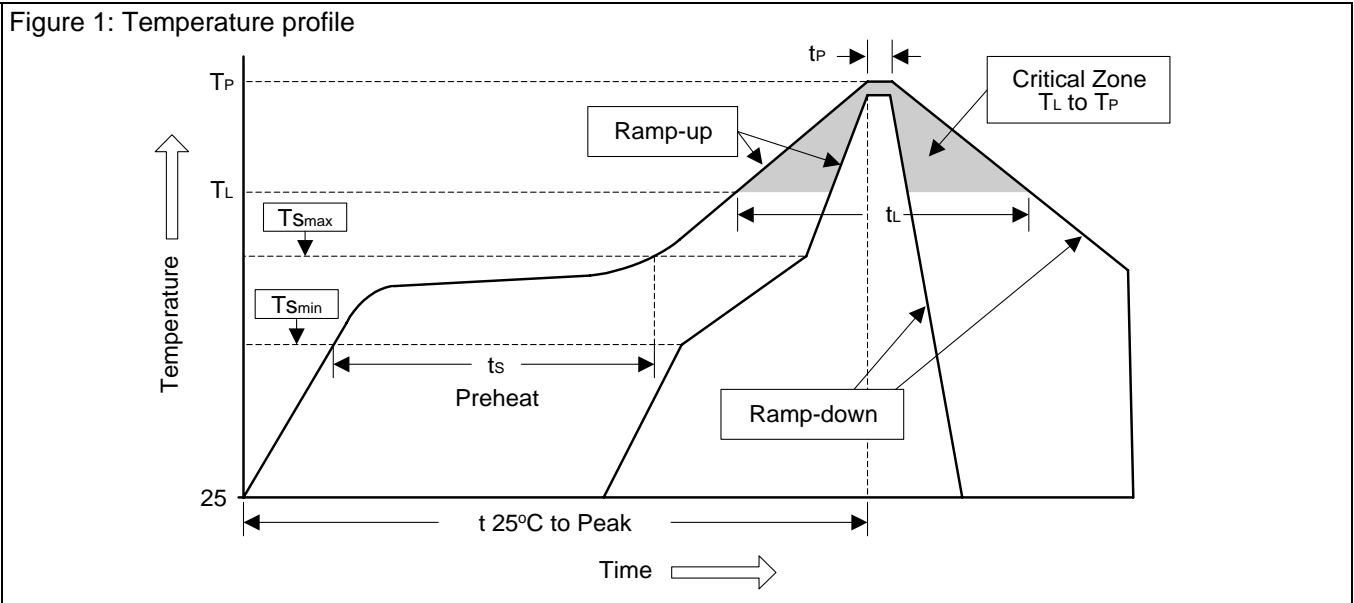

Profile Feature	Sn-Pb Eutectic Assembly	Pb-Free Assembly
Average ramp-up rate (T_L to T_P)	<3°C/sec	<3°C/sec
Preheat		
- Temperature Min (T_{Smin})	100°C	150°C
- Temperature Max (T_{Smax})	150°C	200°C
- Time (min to max) (t_s)	60~120 sec	60~180 sec
T_{Smax} to T_L		
- Ramp-up Rate	<3°C/sec	<3°C/sec
Time maintained above:		
- Temperature (T_L)	183°C	217°C
- Time (t_L)	60~150 sec	60~150 sec
Peak Temperature (T_P)	240°C +0/-5°C	260°C +0/-5°C
Time within 5°C of actual Peak Temperature (t_P)	10~30 sec	20~40 sec
Ramp-down Rate	<6°C/sec	<6°C/sec
Time 25°C to Peak Temperature	<6 minutes	<8 minutes

3. Flow (wave) soldering (solder dipping)

Products	Peak temperature	Dipping time
Pb devices.	245°C ±5°C	5sec ±1sec
Pb-Free devices.	260°C +0/-5°C	5sec ±1sec