

DC/DC Converter Controller

The MC34063AF/AP series is a monolithic control circuit containing the primary functions required for DC-to-DC converters. These devices consist of an internal temperature compensated reference, comparator, controlled duty cycle oscillator with an active current limit circuit. driver and high current output switch. This series was specifically designed to be incorporated in Step-Down or Step-Up or Voltage-Inverting applications with a minimum number of external components.

FEATURES

- Operation from 3.0V to 40V input.
- Low Standby Current.
- Current Limiting.
- Output Switch Current to 1.5A.
- Output Voltage Adjustable.
- Frequency Operation to 100kHz.
- Precision 2% Reference.

Pin Configuration

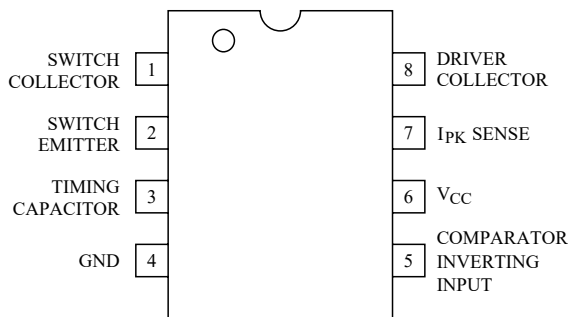

PIN NO.	PIN NAME	PIN NO.	PIN NAME
1	SC	8	DC
2	SE	7	IPK
3	CT	6	VCC
4	GND	5	FB



MC34063AF/AP

MAXIMUM RATINGS (Ta=25°C)

CHARACTERISTIC		SYMBOL	RATING	UNIT
Power Supply Voltage		V_{CC}	40	V
Comparator Input Voltage Range		V_{IR}	-0.3 ~ 40	V
Switch Collector Voltage		$V_{C(SWITCH)}$	40	V
Switch Emitter Voltage ($V_{PIN1}=40V$)		$V_{E(SWITCH)}$	40	V
Switch Collector to Emitter Voltage		$V_{CE(SWITCH)}$	40	V
Driver Collector Voltage		$V_{C(DRIVER)}$	40	V
Driver Collector Current (Note 1)		$I_{C(DRIVER)}$	100	mA
Switch Current		I_{SW}	1.5	A
Power Dissipation	MC34063AP	P_D	500	mW
	MC34063AF		320	
Operating Temperature		T_{opr}	-40 ~ 85	°C
Storage Temperature		T_{stg}	-65 ~ 150	°C

Note 1) Maximum package power dissipation limits must be observed.

BLOCK DIAGRAM

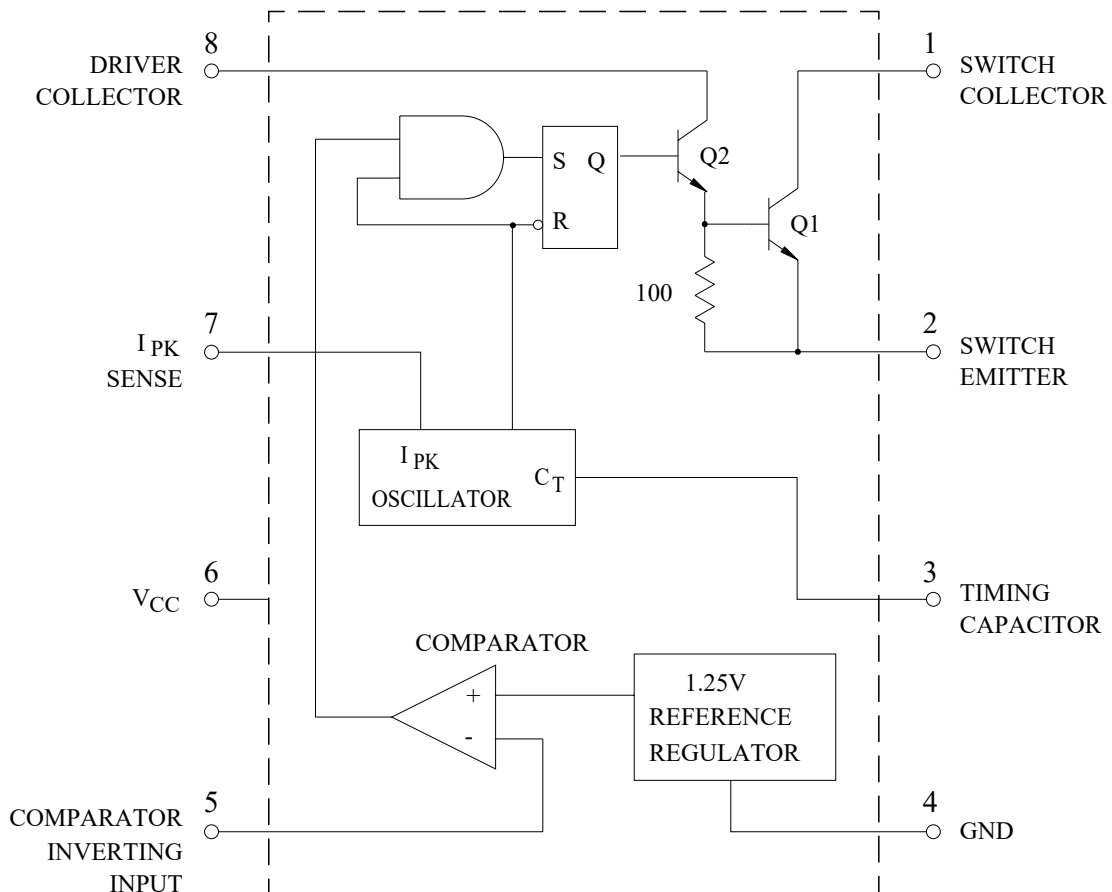



MC34063AF/AP

ELECTRICAL CHARACTERISTICS ($V_{CC}=5.0V$, $T_a=25^\circ C$, unless otherwise specified)

OSCILLATOR SECTION

CHARACTERISTIC	SYMBOL	TEST CONDITION	MIN.	TYP.	MAX.	UNIT
Frequency	f_{OSC}	$V_{PIN5}=0V$, $C_T=1.0nF$	24	33	42	kHz
Charge Current	I_{CHG}	$V_{CC}=5.0 \sim 40V$	24	33	42	μA
Discharge Current	I_{DISCHG}	$V_{CC}=5.0 \sim 40V$	140	200	260	μA
Discharge to Charge Current Ratio	I_{DISCHG}/I_{CHG}	Pin 7 ~ V_{CC}	5.2	6.5	7.5	-
Current Limit Sense Voltage	$V_{IPK(SENSE)}$	$I_{DISCHG}=I_{CHG}$	250	300	350	mV

OUTPUT SWITCH SECTION (Note 2)

CHARACTERISTIC	SYMBOL	TEST CONDITION	MIN.	TYP.	MAX.	UNIT
Saturation Voltage, Darlington Connection	$V_{CE(SAT1)}$	$I_{SW}=1.0A$, Pins 1, 8 Connection	-	1.0	1.3	V
Saturation Voltage (Note 3)	$V_{CE(SAT2)}$	$I_{SW}=1.0A$, Forced $\beta = \simeq 20$ $R_{PIN8}=82 \Omega$ to V_{CC}	-	0.45	0.7	V
DC Current Gain	h_{FE}	$I_{SW}=1.0A$, $V_{CE}=5.0A$,	-	-	1.2	-
Collector Off-State Current	$I_{C(OFF)}$	$V_{CE}=40V$	-	0.01	100	μA

COMPARATOR SECTION

CHARACTERISTIC	SYMBOL	TEST CONDITION	MIN.	TYP.	MAX.	UNIT
Threshold Voltage	V_{TH}	$T_a=T_{LOW} \sim T_{HIGH}$	1.21	-	1.29	V
Threshold Voltage Line Regulation	Reg line	$V_{CC}=3.0 \sim 40V$	-	1.4	5.0	mV
Input Bias Current	I_{IB}	$V_{IN}=0$	-	-40	-400	nA

TOTAL DEVICE

CHARACTERISTIC	SYMBOL	TEST CONDITION	MIN.	TYP.	MAX.	UNIT
Supply Current	I_{CC}	$V_{CC}=5.0 \sim 40V$, $C_T=1.0nF$, Pin 7= V_{CC} , Pin 2=GND, $V_{PIN5}>V_{TH}$, remaining pins open	-	-	4.0	mA

Note) 2. Low duty cycle pulse techniques are used during test to maintain junction temperature as close to ambient temperature as possible.

3. If the output switch is driven into hard saturation (non-Darlington configuration) at low switch currents ($\leq 300mA$) and high driver currents ($\geq 30mA$), it may take up to $2.0\mu S$ for it to come out of saturation. This condition will shorten the off time at frequencies $\geq 30kHz$, and is magnified at high temperatures. This condition does not occur with a Darlington configuration, since the output switch cannot saturate. If a non-Darlington configuration is used, the following output drive condition is recommended ;

$$\text{Forced of output switch : } \frac{I_{C \text{ output}}}{I_{C \text{ driver}-7.0mA *}} \geq 10$$

* The 100Ω resistor in the emitter of the driver device requires about $7.0mA$ before the output switch conducts.

APPLICATION CIRCUIT

(1) Step-up Converter

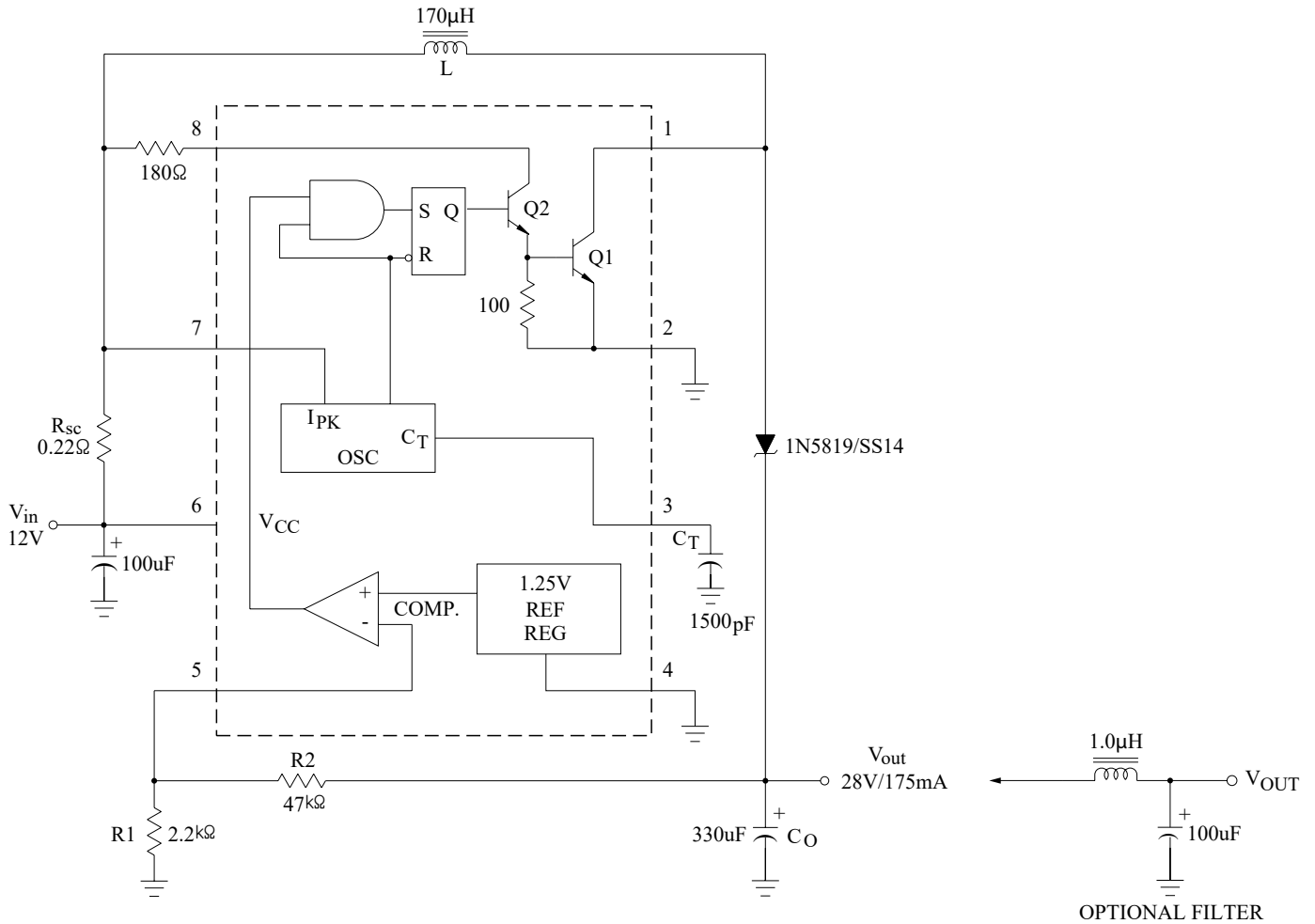

TEST	CONDITIONS	RESULTS
Line Regulation	$V_{IN}=8.0V$ to $16V$, $I_O=175mA$	30mV
Load Regulation	$V_{IN}=12V$, $I_O=75mA$ to $175mA$	10mV
Output Ripple	$V_{IN}=12V$, $I_O=175mA$	300 mVpp

(2) Step-Down Converter

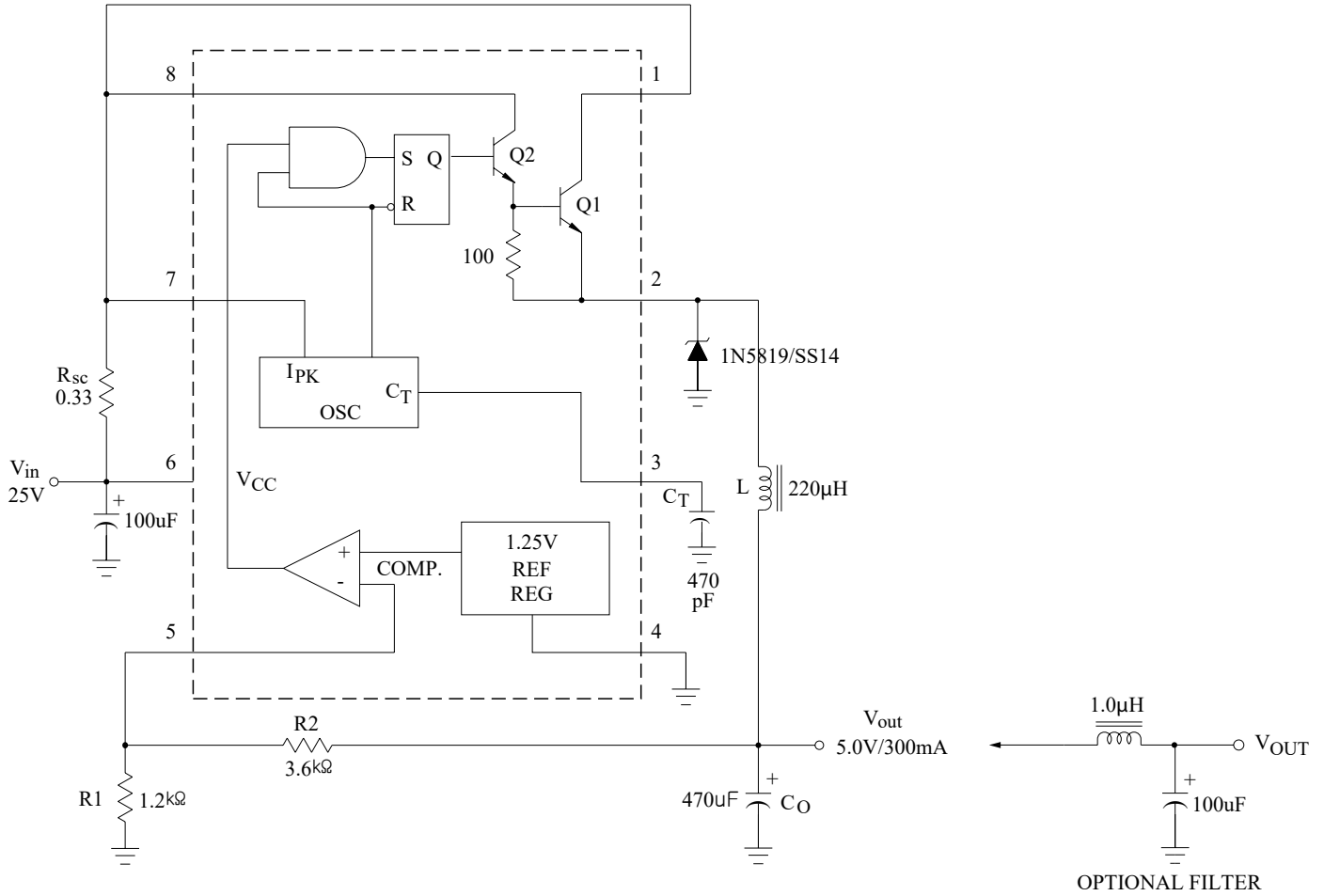

$$V_{OUT} = 1.25 * (1 + R2/R1)$$

TEST	CONDITIONS	RESULTS
Line Regulation	$V_{IN}=15V$ to $25V$, $I_O=300mA$	12mV
Load Regulation	$V_{IN}=25V$, $I_O=50mA$ to $300mA$	22mV
Output Ripple	$V_{IN}=25V$, $I_O=300mA$	500 mVpp
Short Circuit Current	$V_{IN}=25V$, $R_L=0.1\Omega$	0.51A
Efficiency	$V_{IN}=25V$, $I_O=300mA$	64.5%

(3) Voltage Inverting Converter

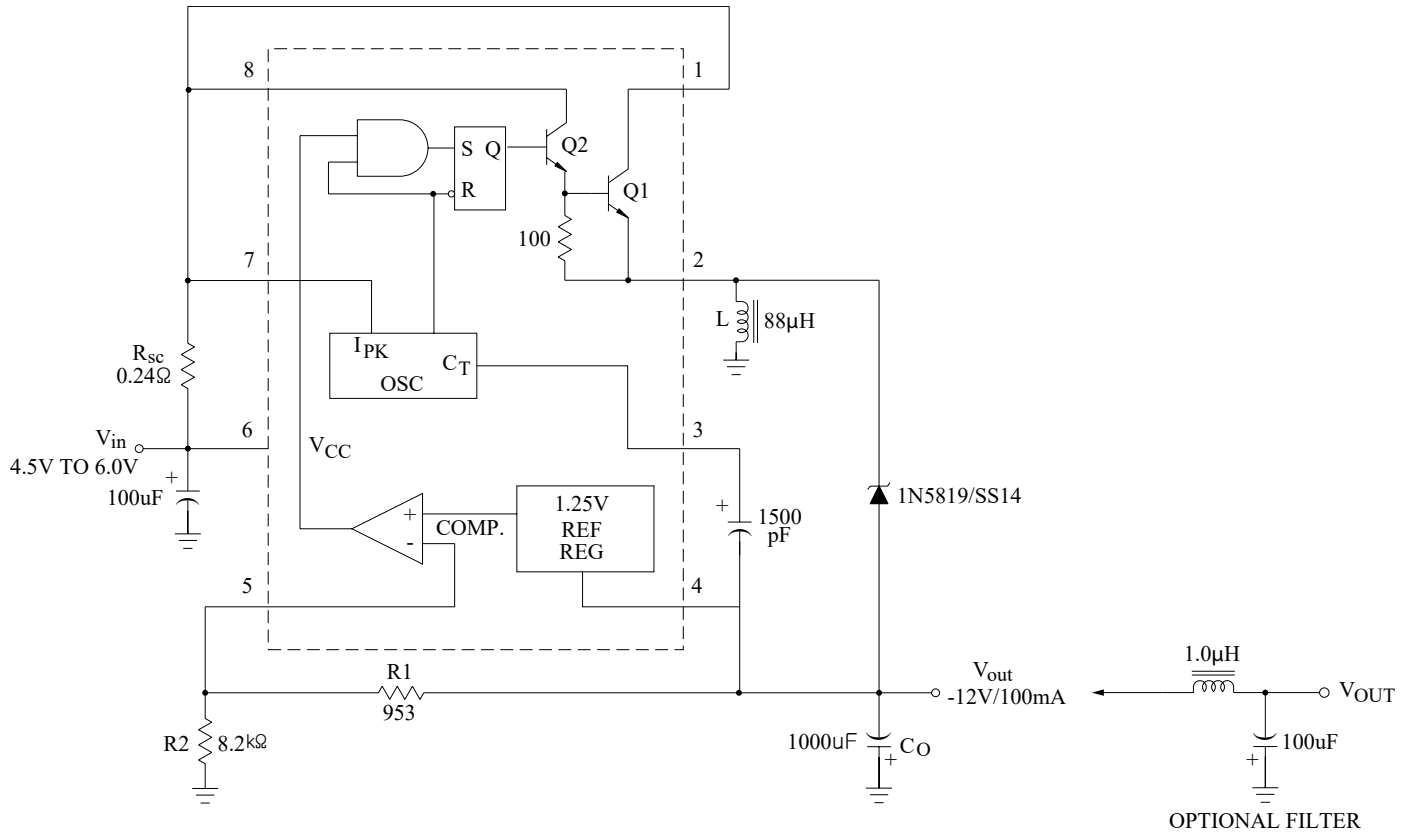

TEST	CONDITIONS	RESULTS
Line Regulation	$V_{IN}=4.5V$ to $6.0V$, $I_O=100mA$	3mV
Load Regulation	$V_{IN}=5.0V$, $I_O=10mA$ to $100mA$	22mV
Output Ripple	$V_{IN}=5.0V$, $I_O=100mA$	500 mVpp



MC34063AF/AP

Calculation

Parameter	Step-Up (Discontinuous mode)	Step-Down (Continuous mode)	Voltage Inverting (Discontinuous mode)
t_{on}/t_{off}	$\frac{V_{out} + V_F - V_{in(min)}}{V_{in(min)} - V_{sat}}$	$\frac{V_{out} + V_F}{V_{in(min)} - V_{sat} - V_{out}}$	$\frac{ V_{out} + V_F}{V_{in} - V_{sat}}$
$(t_{on} + t_{off})_{max}$	$1/f_{min}$	$1/f_{min}$	$1/f_{min}$
C_T	$4.5 \times 10^{-5} t_{on}$	$4.5 \times 10^{-5} t_{on}$	$4.5 \times 10^{-5} t_{on}$
$I_{PK(switch)}$	$2I_{out(max)}[(t_{on}/t_{off})+1]$	$2I_{out(max)}$	$2I_{out(max)}[(t_{on}/t_{off})+1]$
R_{SC}	$0.3/I_{PK(switch)}$	$0.3/I_{PK(switch)}$	$0.3/I_{PK(switch)}$
C_O	$\equiv \frac{I_{out} t_{on}}{V_{ripple(p-p)}}$	$\frac{I_{PK(switch)} (t_{on} + t_{off})}{8V_{ripple(p-p)}}$	$\equiv \frac{I_{out} t_{on}}{V_{ripple(p-p)}}$
$L(min)$	$\frac{V_{in(min)} - V_{sat}}{I_{PK(switch)}} t_{on(max)}$	$\frac{V_{in(min)} - V_{sat} - V_{out}}{I_{PK(switch)}} t_{on(max)}$	$\frac{V_{in(min)} - V_{sat}}{I_{PK(switch)}} t_{on(max)}$

NOTES:

V_{sat} = Saturation voltage of the output switch

V_F = Forward voltage drop of the output rectifier

THE FOLLOWING POWER SUPPLY CHARACTERISTICS MUST BE CHOSEN:

V_{in} = Nominal input voltage

V_{out} = Desired output voltage, $|V_{out}| = 1.25(1+R_2/R_1)$

I_{out} = Desired output current

f_{min} = Minimum desired output switching frequency at the selected values of V_{in} and I_o

V_{ripple} = Desired peak to peak output ripple voltage. In practice, the calculated capacitor value will and to be increased due to its equivalent series resistance and board layout. The ripple voltage should be kept to a low value since it will directly affect the line and load regulation.

Packaging Information

Package Type: DIP-8

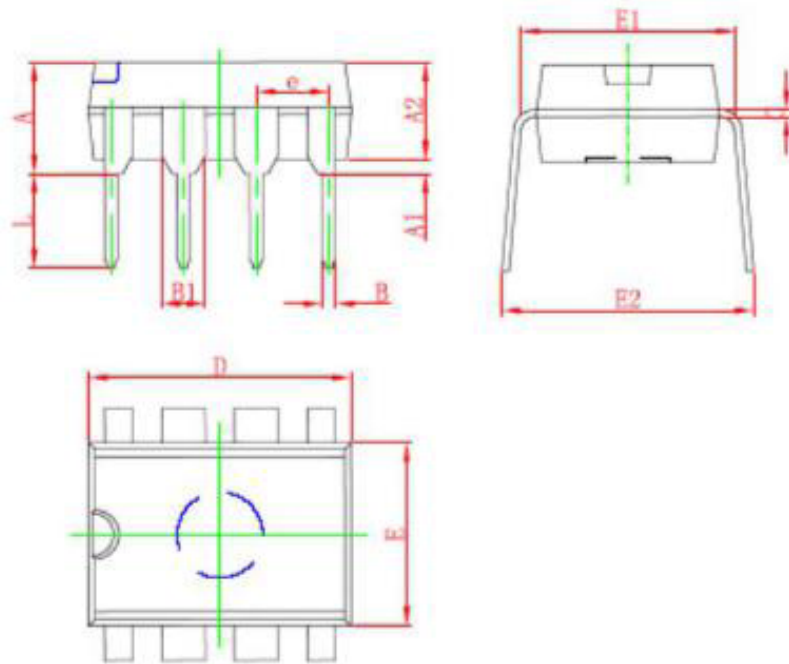

Symbol	Dimensions In Millimeters		Dimensions In Inches	
	Min	Max	Min	Max
A	3.710	4.310	0.146	0.170
A1	0.510		0.020	
A2	3.200	3.600	0.126	0.142
B	0.380	0.570	0.015	0.022
B1	1.524 (BSC)		0.060 (BSC)	
C	0.204	0.360	0.008	0.014
D	9.000	9.400	0.354	0.370
E	6.200	6.600	0.244	0.260
E1	7.320	7.920	0.288	0.312
e	2.540 (BSC)		0.100 (BSC)	
L	3.000	3.600	0.118	0.142
E2	8.400	9.000	0.331	0.354

Packaging Information

Package Type: SOP-8

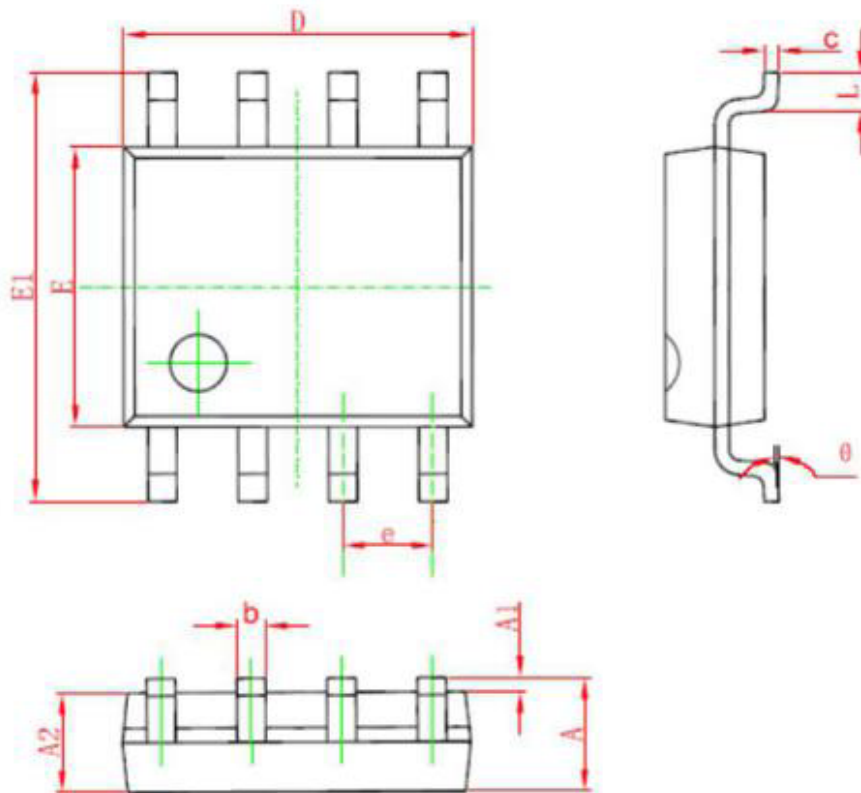

Symbol	Dimensions In Millimeters		Dimensions In Inches	
	Min	Max	Min	Max
A	1.350	1.750	0.053	0.069
A1	0.100	0.250	0.004	0.010
A2	1.350	1.550	0.053	0.061
b	0.330	0.510	0.013	0.020
c	0.170	0.250	0.006	0.010
D	4.700	5.100	0.185	0.200
E	3.800	4.000	0.150	0.157
E1	5.800	6.200	0.228	0.244
e	1.270 (BSC)		0.050 (BSC)	
L	0.400	1.270	0.016	0.050
θ	0°	8°	0°	8°