

8 HIGH-VOLTAGE HIGH-CURRENT DARLINGTON TRANSISTOR ARRAYS

The FD6208* series are high-voltage, high-current darlington drivers comprised of eight NPN darlington pairs. All units feature integral clamp diodes for switching inductive loads. Applications include relay, hammer, lamp and display(LED) drivers.

FEATURES

- Output Current (Single Output) : 500mA Max.
- High Sustaining Voltage Outputs : 50V Min.
- Output Clamp Diodes
- Inputs Compatible With Various Types of Logic.
- PKG Type, AP : DIP-18Pin.
- PKG Type, AF : SOP-20Pin

TYPE	INPUT BASE RESISTOR	DESIGNATION
FD62083	2.7kΩ	TTL, 5V C-MOS
FD62084	10.5kΩ	6 ~ 15V P-MOS, C-MOS

MAXIMUM RATINGS (Ta=25°C, unless otherwise noted)

CHARACTERISTIC		SYMBOL	RATING	UNIT
Output Sustaining Voltage		$V_{CE(SUS)}$	-0.5 ~ 50	V
Output Current		I_{OUT}	500	mA/ch
Input Voltage		V_{IN}	-0.5 ~ +30	V
Clamp Diode	Reverse Voltage	V_R	50	V
	Forward Current	I_F	500	mA
Power Dissipation	AP	P_D	1.47	W
	AF		0.96	W
Operating Temperature		T_{opr}	-40 ~ 85	°C
Storage Temperature		T_{stg}	-55 ~ 150	°C

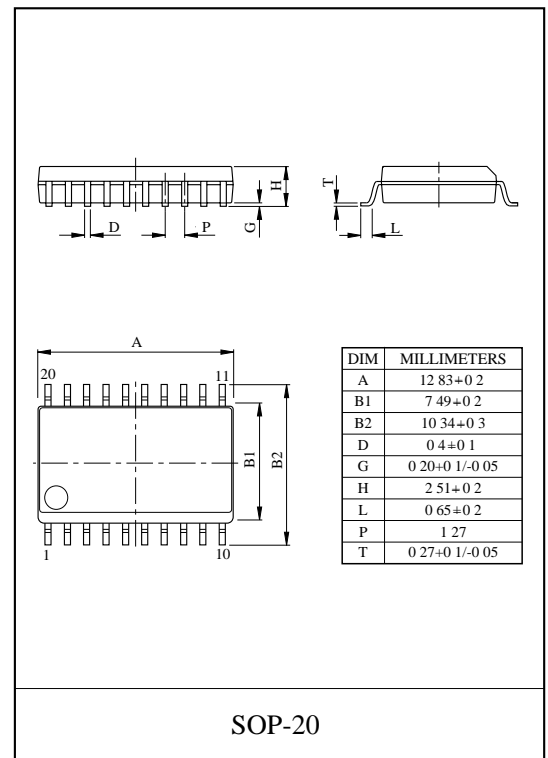
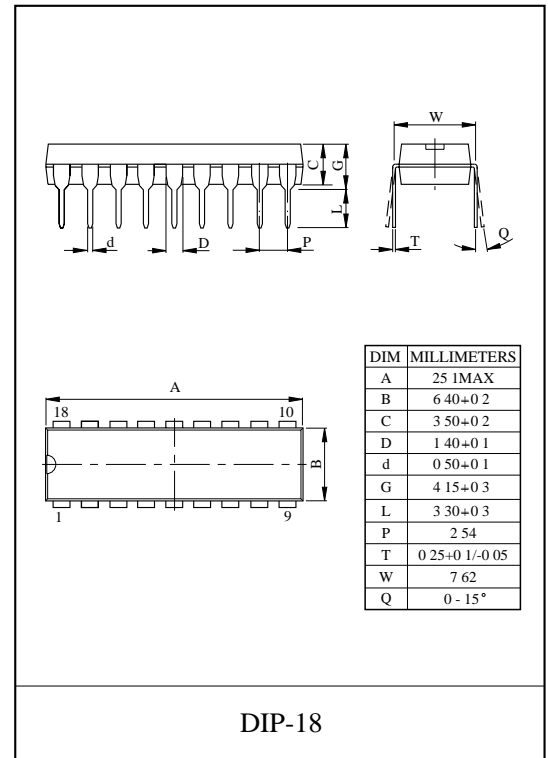

PIN CONNECTION (TOP VIEW)

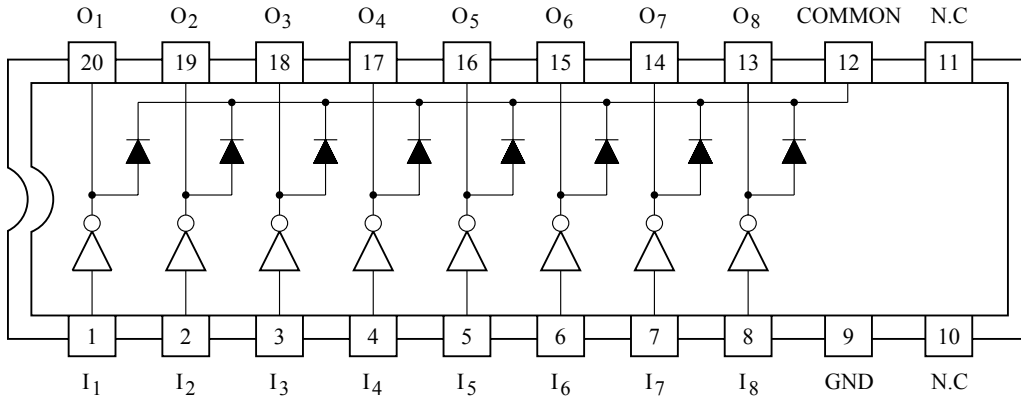

FD62083

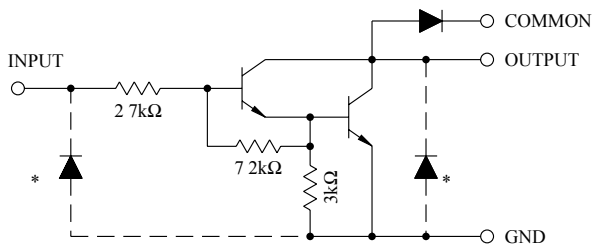

FD62084

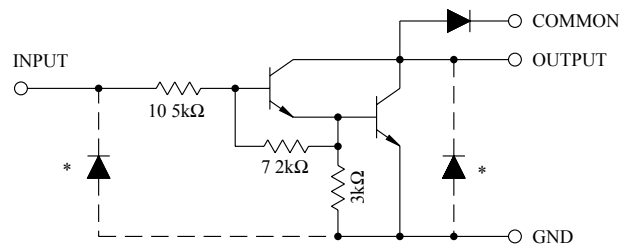

(* : Parasitic Diodes
 NOTE. The input and output parasitic diodes cannot be used as clamp diodes.)



FD62083AP/AF FD62084AP/AF

RECOMMENDED OPERATING CONDITIONS (Ta=-40 ~ 85°C)

CHARACTERISTIC		SYMBOL	CONDITION	MIN.	TYP.	MAX.	UNIT
Output Sustaining Voltage		$V_{CE(SUS)}$		0	-	50	V
Output Current	AP	I_{OUT}	$T_{PW}=25ms, Duty=10\%, 8 Circuits$	0	-	347	mA/ch
			$T_{PW}=25ms, Duty=50\%, 8 Circuits$	0	-	123	
	AF		$T_{PW}=25ms, Duty=10\%, 8 Circuits$	0	-	268	
			$T_{PW}=25ms, Duty=50\%, 8 Circuits$	0	-	90	
Input Voltage		V_{IN}		0	-	30	V
Input Voltage (Output ON)	FD62083	$V_{IN(ON)}$		3.5	-	30	V
	FD62084			8	-	30	
Clamp Diode Reverse Voltage		V_R		-	-	50	V
Clamp Diode Forward Current		I_F		-	-	400	mA
Power Dissipation	AP	P_D		-	-	0.52	W
	AF			-	-	0.35	



FD62083AP/AF FD62084AP/AF

ELECTRICAL CHARACTERISTICS (Ta=25 °C, unless otherwise noted)

CHARACTERISTICS		SYMBOL	TEST CIRCUIT	TEST CONDITION	MIN.	TYP.	MAX.	UNIT
Output Leak Current	FD62083	I _{CEX}	1	V _{CE} =50V, Ta=25 °C	-	-	50	μA
				V _{CE} =50V, Ta=85 °C	-	-	100	
	FD62084			V _{CE} =50V, V _{IN} =1V	-	-	500	
Collector-Emitter Saturation Voltage		V _{CE(sat)}	2	I _{OUT} =350mA, I _{IN} =500μA	-	1.3	1.6	V
				I _{OUT} =200mA, I _{IN} =350μA	-	1.1	1.3	
				I _{OUT} =100mA, I _{IN} =250μA	-	0.9	1.1	
Input Current	FD62083	I _{IN(ON)}	3	V _{IN} =3.85V	-	0.93	1.35	mA
	FD62084			V _{IN} =5V	-	0.35	0.5	
				V _{IN} =12V	-	1.0	1.45	
		I _{IN(OFF)}	4	I _{OUT} =500μA, Ta=85 °C	50	65	-	μA
Input Voltage (Output On)	FD62083	V _{IN(ON)}	5	V _{CE} =2V, I _{OUT} =200mA	-	-	2.4	V
				V _{CE} =2V, I _{OUT} =250mA	-	-	2.7	
				V _{CE} =2V, I _{OUT} =300mA	-	-	3.0	
	FD62084			V _{CE} =2V, I _{OUT} =125mA	-	-	5.0	
	V _{CE} =2V, I _{OUT} =200mA			-	-	6.0		
	V _{CE} =2V, I _{OUT} =275mA			-	-	7.0		
	V _{CE} =2V, I _{OUT} =350mA			-	-	8.0		
DC Current Transfer Ratio		h _{FE}	2	V _{CE} =2V, I _{OUT} =350mA	1000	-	-	
Clamp Diode Reverse Current		I _R	6	Ta=25 °C (*1)	-	-	50	μA
				Ta=85 °C (*1)	-	-	100	
Clamp Diode Forward Voltage		V _F	7	I _F =350mA	-	-	2.0	V
Input Capacitance		C _{IN}			-	-	15	pF
Turn-On Delay		t _{ON}	8	R _L =125Ω, V _{OUT} =50V	-	0.1	-	μs
Turn-Off Delay		t _{OFF}			-	0.21	-	

*1 VR=VR MAX

TEST CIRCUIT

1. I_{CEX}

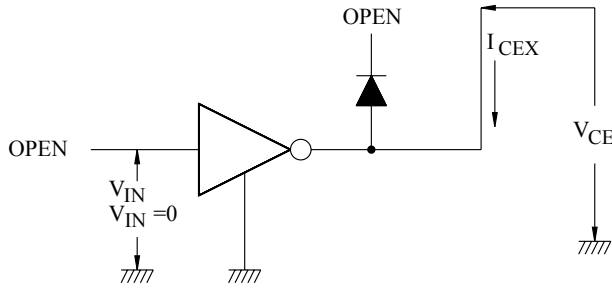

2. $V_{CE(sat)}$, h_{FE}

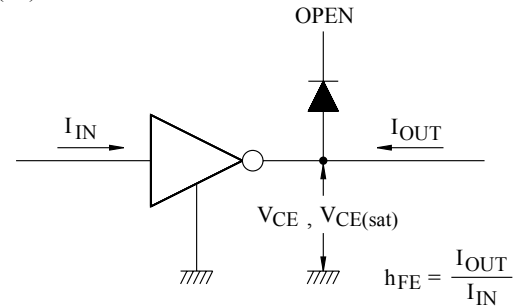

3. $I_{IN(ON)}$

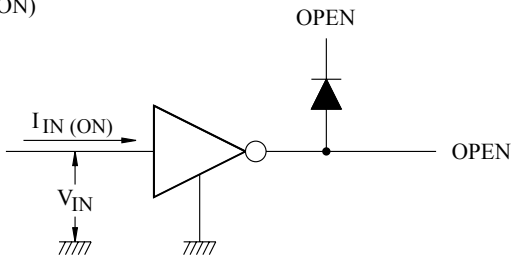

4. $I_{IN(OFF)}$

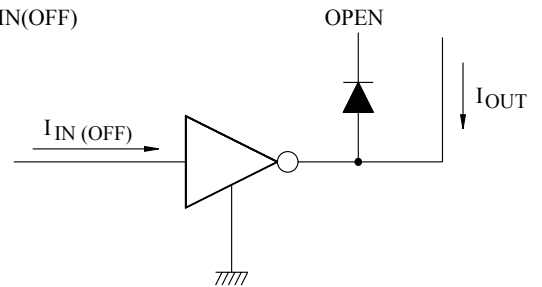

5. $V_{IN(ON)}$

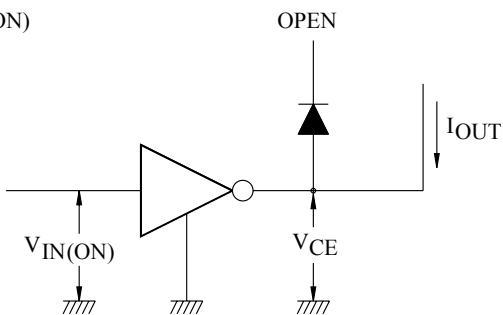

6. I_R

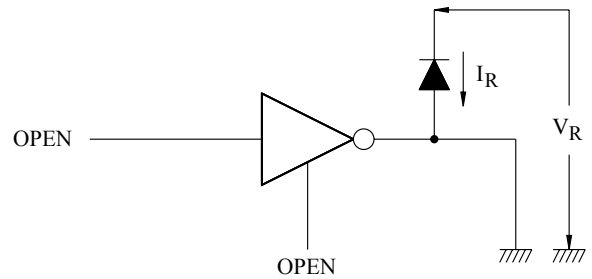

7. V_F

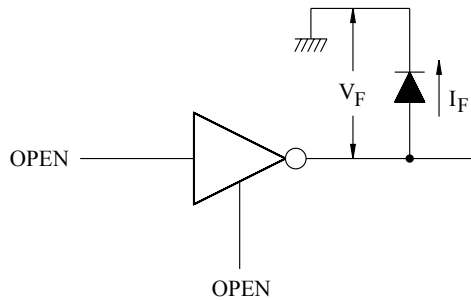

8. t_{ON} , t_{OFF}

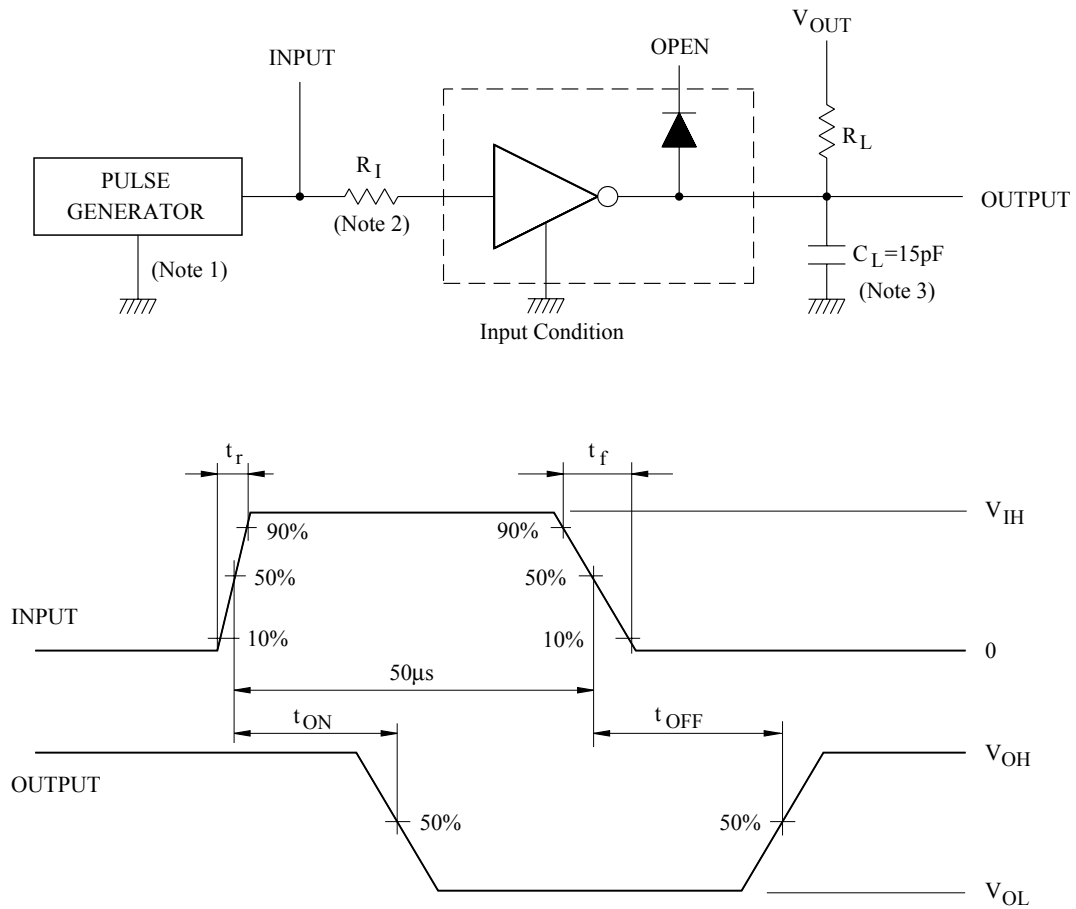

Notes : 1. Pulse Width $50\mu\text{s}$, Duty Cycle 10%
Output Impedance 50Ω , $t_r \leq 5\text{ns}$, $t_f \leq 10\text{ns}$

2. See below

Input Conditions

Type Number	R_I	V_{IH}
FD62083	0	3V
FD62084	0	8V

3. C_L includes probe and Jig capacitance.



FD62083AP/AF FD62084AP/AF

$I_{IN} - V_{IN}$

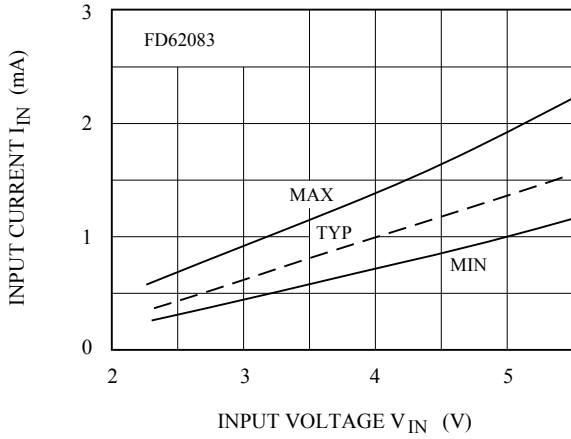

$I_{IN} - V_{IN}$

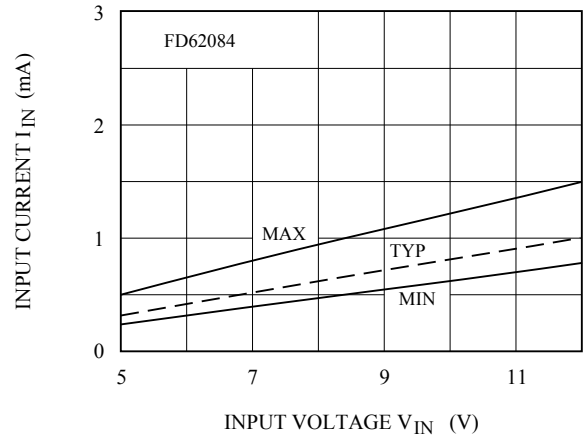

$I_{OUT} - V_{CE(sat)}$

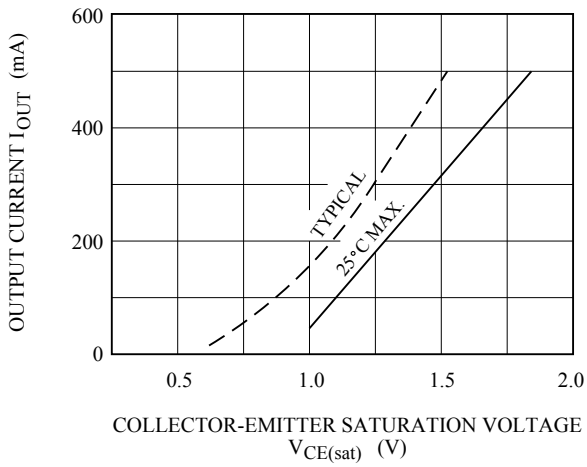

$I_{OUT} - DUTY CYCLE$

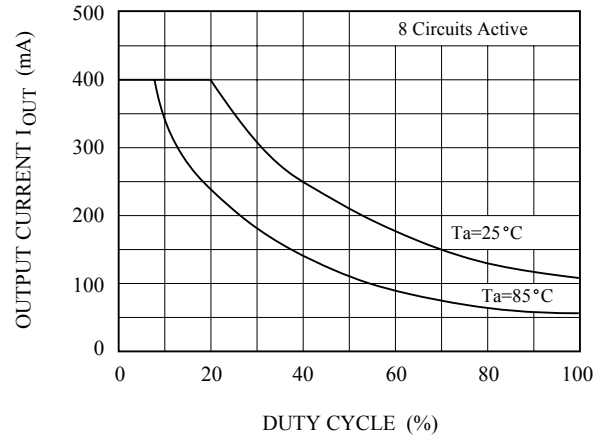

$P_D - T_a$

