

300mA CMOS LDO Regulator Low Dropout Voltage

INTRODUCTION

The FC6219 Series are a group of positive voltage regulators manufactured by CMOS technologies with high ripple rejection, extremely low power consumption and low dropout voltage, which provide large output currents even when the difference of the input-output voltage is small. Thus the FC6219 series are very suitable for the battery-powered equipments, such as portable/palm computers, portable consumer equipments, industry equipments and so on, which want to prolong the using life of the battery.

APPLICATIONS

- Battery powered systems
- Portable instrumentations
- Radio control systems

BLOCK DIAGRAM

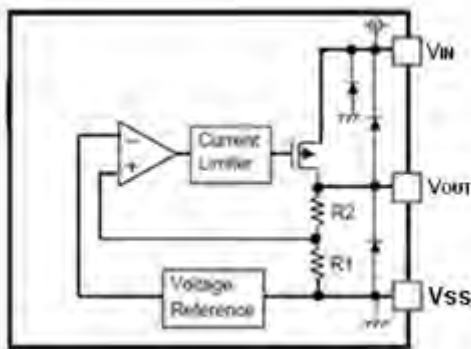

FEATURES

- Output Current: 300mA
 - Output Voltage Range: 0.9V ~ 5.0V, (selectable in 0.1V steps)
 - High Accuracy: ± 2 or $\pm 1\%$
 - Low Dropout Voltage: 150mV@100mA (3.0V Typ.)
 - Excellent Line Regulation: 0.1%/V
 - Built-in Current Limiter
 - Built-in Short Circuit Protection
 - Static safety: 2KV@HBM
 - TC: 100ppm/°C
 - Ceramic Capacitor Compatible
-
- Portable consumer equipments
 - Portable/Palm computers
 - Reference Voltage Sources

ORDER INFORMATION

FC6219①②③④⑤⑥⑦

DESIGNATOR	SYMBOL	DESCRIPTION
①	P	Standard
②③	Integer	Output Voltage(0.9~5V) e.g:3.0V=②:3, ③:0
④	Integer	Output Voltage Accuracy 2 = $\pm 2.0\%$, 3 = $\pm 3.0\%$
⑤	M	Package:SOT-23-3
	P	Package:SOT-89-3
	T	Package:TO-92
	MR	Package:SOT-23-5
⑥	R	Embossed Tape(Right)
	L	Embossed Tape(Left)
	B	Bag(TO-92)
	H	Paper Tape(TO-92)
⑦	G	Lead Free Part

PIN CONFIGURATION (Pin output sequence can be ordered by customer)

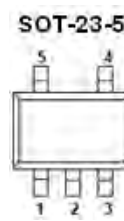
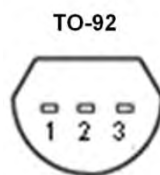
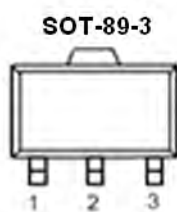
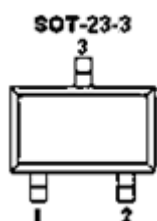

PIN NUMBER						PIN NAME	FUNCTION
SOT-23-3		SOT-89-3			TO-92		
M	MC	P	PT	PW	T		
1	3	1	2	1	1	V_{SS}	Ground
2	2	3	1	2	3	V_{OUT}	Output
3	1	2	3	3	2	V_{IN}	Power input

SOT-23-5

PIN NUMBER	SYMBOL	FUNCTION
1	V_{IN}	Power Input Pin
2	V_{SS}	Ground
3	NC	No Connection
4	NC	No Connection
5	V_{OUT}	Output Pin

ABSOLUTE MAXIMUM RATINGS ($T_a=25^{\circ}\text{C}$ unless otherwise specified)

PARAMETER	SYMBOL	RATINGS	UNITS
Input Voltage	V_{IN}	$V_{SS}-0.3\sim V_{SS}+8$	V
Output Current	I_{OUT}	600	mA
Output Voltage	V_{OUT}	$V_{SS}-0.3\sim V_{IN}+0.3$	V
Power Dissipation	SOT-23-3	P_d	250
	SOT-23-5	P_d	250
	SOT-89-3	P_d	500
	TO-92	P_d	500
Operating Temperature	T_{opr}	-40~+85	$^{\circ}\text{C}$
Storage Temperature	T_{stg}	-40~+125	$^{\circ}\text{C}$
Soldering Temperature & Time	T_{solder}	260 $^{\circ}\text{C}$, 10s	

ELECTRICAL CHARACTERISTICS

($V_{IN}=V_{OUT}+1V$, $C_{IN}=C_{OUT}=1\mu F$, $T_a=25^\circ C$, unless otherwise specified)

PARAMETER	SYMBOL	CONDITIONS	MIN	TYP	MAX	UNITS	
Output Voltage	$V_{OUT(E)}$ (Note 2)	$I_{OUT}=40mA$, $V_{IN}=V_{OUT}+1V$, $V_{IN}\geq 2V$	$1.5V < V_{OUT} \leq 5.0V$	V_{OUT} *0.98	V_{OUT} (Note 1)	V_{OUT} *1.02	V
			$0.9V \leq V_{OUT} \leq 1.5V$	V_{OUT} -0.03	V_{OUT}	V_{OUT} +0.03	V
Supply Current	I_{SS}	$V_{CE}=V_{IN}=V_{OUT}+1V$		5		μA	
Output Current	I_{OUT}	$V_{IN}\geq 2V$, $V_{IN}=V_{OUT}+1V$	300			mA	
Dropout Voltage (Note 3)	V_{dif1}	$I_{OUT} = 40mA$		60		mV	
	V_{dif2}	$I_{OUT} = 100mA$		150		mV	
Load Regulation	ΔV_{OUT}	$V_{IN}= V_{OUT} +1V$, $1mA \leq I_{OUT} \leq 100mA$		10		mV	
Line Regulation	$\frac{\Delta V_{OUT}}{\Delta V_{IN} * V_{OUT}}$	$I_{OUT} = 40mA$ $V_{OUT} +1V \leq V_{IN} \leq 6V$		0.1	0.3	%/V	
Output Voltage Temperature Characteristics	$\frac{\Delta V_{OUT}}{\Delta T * V_{OUT}}$	$I_{OUT} = 40mA$ $-40 \leq T \leq +85$		100		ppm/ $^\circ C$	
Power Supply Ripple Rejection	PSRR	$I_{OUT} = 10mA$ $f = 1KHz$		40		dB	
Short Current	I_{Short}	$V_{OUT} = V_{SS}$		30		mA	
Current Limit	I_{Lim}	$V_{IN}= V_{OUT} +1V$		600		mA	
Input Voltage	V_{IN}	—	2.0		7.0	V	

NOTE:

- V_{OUT} : Specified Output Voltage.
- $V_{OUT} (E)$: Effective Output Voltage (I.e. The Output Voltage When $V_{IN} = (V_{OUT} +1.0V)$ And Maintain A Certain I_{OUT} Value).
- V_{dif} : The Difference Of Output Voltage And Input Voltage When Input Voltage Is Decreased Gradually Till Output Voltage Equals To 98% Of $V_{OUT} (E)$; When $V_{OUT} < 2.0V$, $V_{IN} \geq 2.0V$ Should be Guaranteed.

TYPICAL APPLICATION CIRCUIT

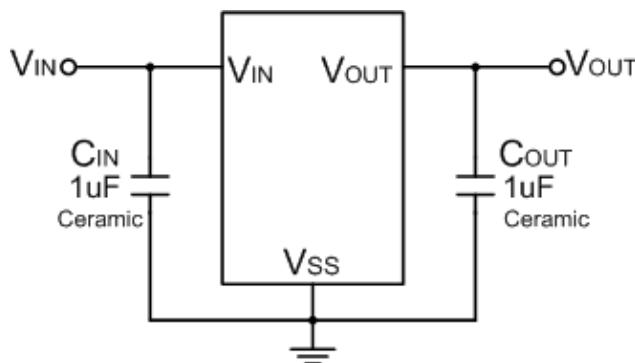

TYPICAL PERFORMANCE CHARACTERISTICS

(1) Output Voltage vs. Input Voltage

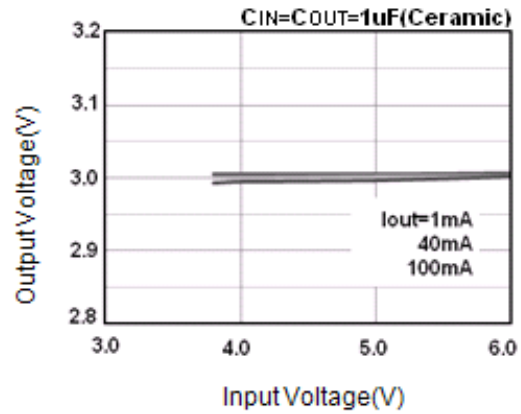
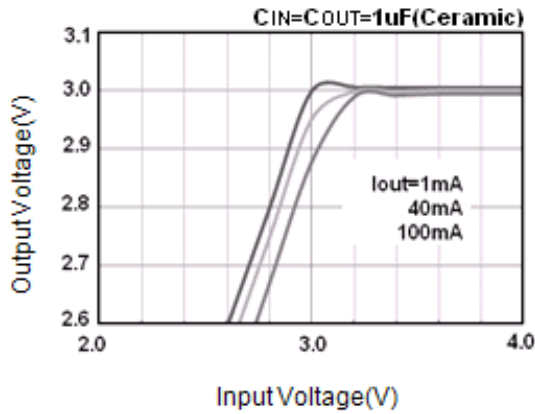

(2) Input Transient Response 1

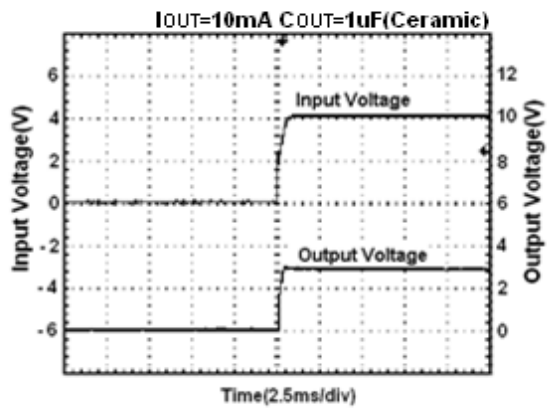
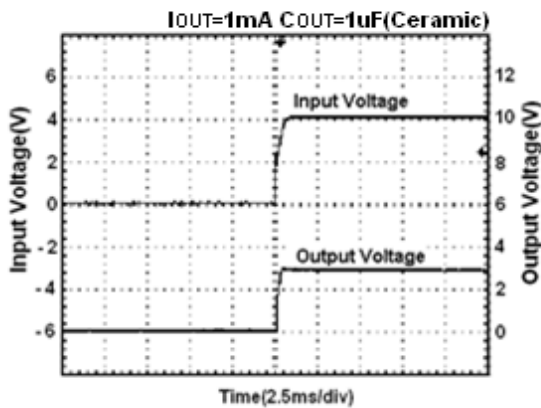

(3) Input Transient Response 2

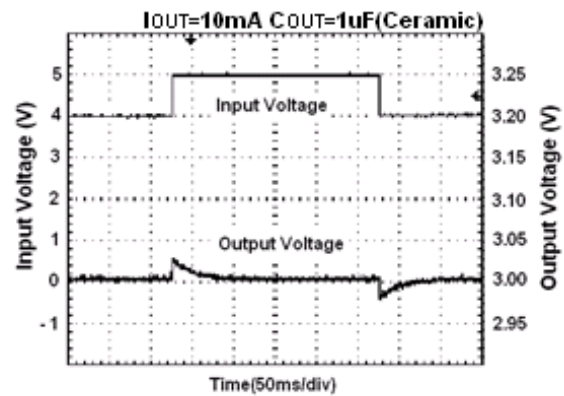
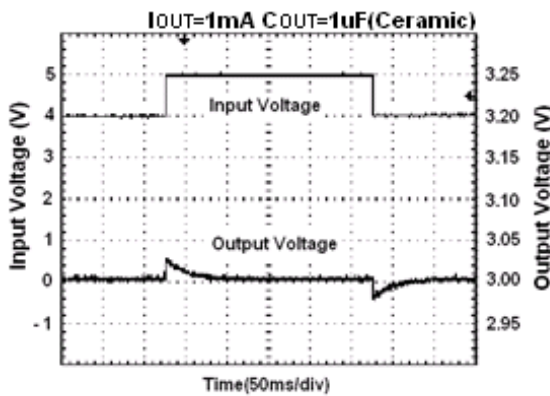

TYPICAL PERFORMANCE CHARACTERISTICS (Con.)

(4) Output Voltage vs. Temperature

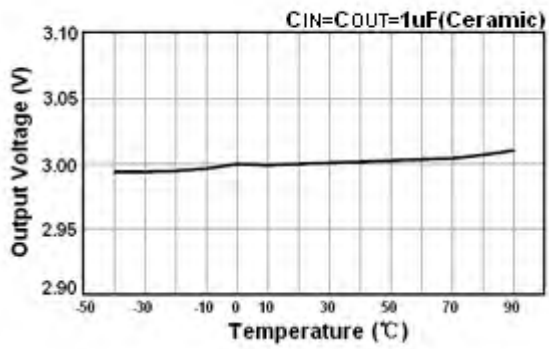

PACKAGING INFORMATION

SOT-23-3 PACKAGE OUTLINE DIMENSIONS

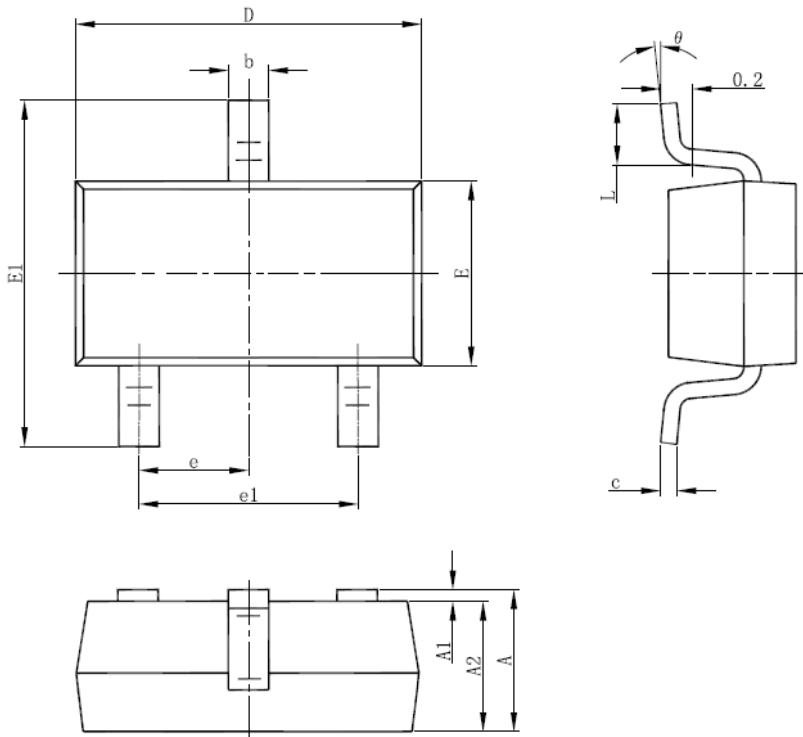

Symbol	Dimensions In Millimeters		Dimensions In Inches	
	Min	Max	Min	Max
A	1.050	1.250	0.041	0.049
A1	0.000	0.100	0.000	0.004
A2	1.050	1.150	0.041	0.045
b	0.300	0.500	0.012	0.020
c	0.100	0.200	0.004	0.008
D	2.820	3.020	0.111	0.119
E	1.500	1.700	0.059	0.067
E1	2.650	2.950	0.104	0.116
e	0.950(BSC)		0.037(BSC)	
e1	1.800	2.000	0.071	0.079
L	0.300	0.600	0.012	0.024
θ	0°	8°	0°	8°

SOT-23-5 PACKAGE OUTLINE DIMENSIONS

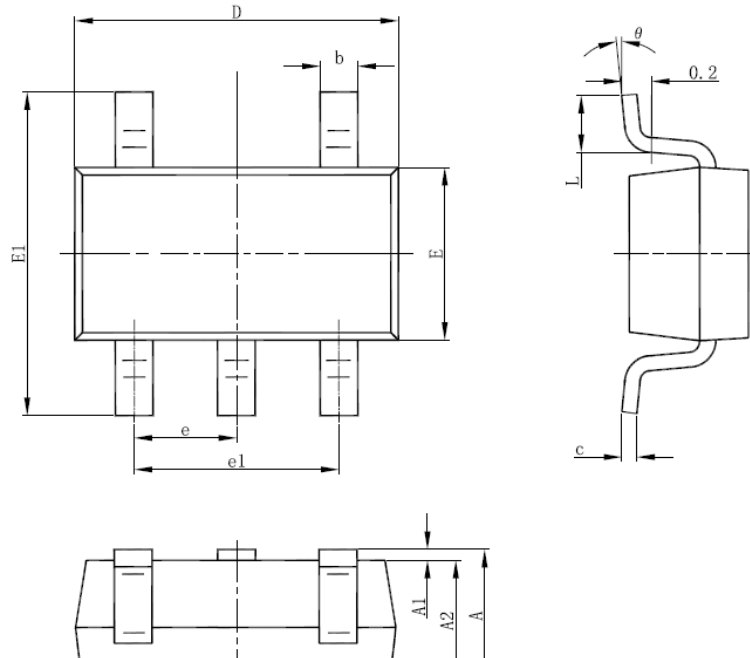

Symbol	Dimensions In Millimeters		Dimensions In Inches	
	Min	Max	Min	Max
A	1.050	1.250	0.041	0.049
A1	0.000	0.100	0.000	0.004
A2	1.050	1.150	0.041	0.045
b	0.300	0.500	0.012	0.020
c	0.100	0.200	0.004	0.008
D	2.820	3.020	0.111	0.119
E	1.500	1.700	0.059	0.067
E1	2.650	2.950	0.104	0.116
e	0.950(BSC)		0.037(BSC)	
e1	1.800	2.000	0.071	0.079
L	0.300	0.600	0.012	0.024
θ	0°	8°	0°	8°

SOT-89-3 PACKAGE OUTLINE DIMENSIONS

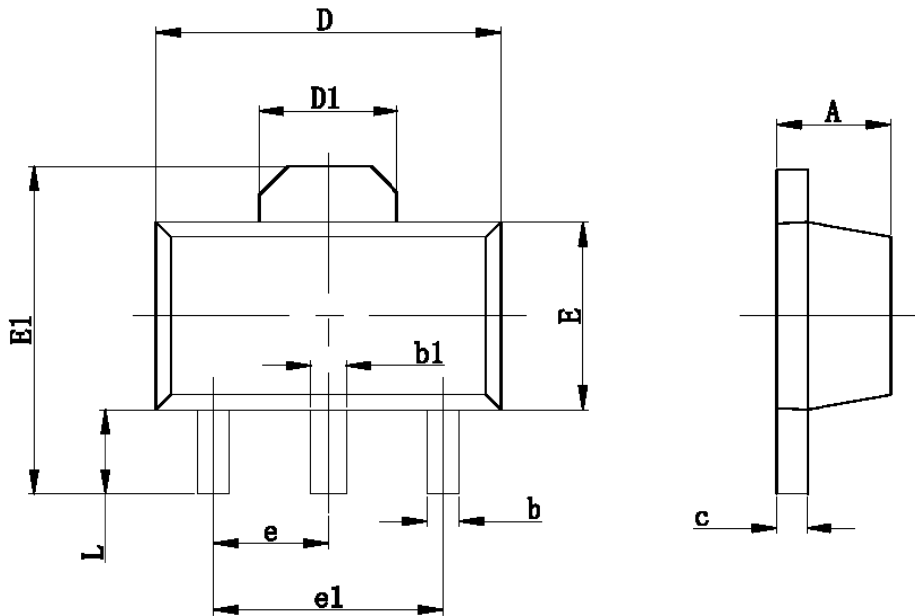

Symbol	Dimensions In Millimeters		Dimensions In Inches	
	Min	Max	Min	Max
A	1.400	1.600	0.055	0.063
b	0.320	0.520	0.013	0.197
b1	0.400	0.580	0.016	0.023
c	0.350	0.440	0.014	0.017
D	4.400	4.600	0.173	0.181
D1	1.550 REF		0.061 REF	
E	2.300	2.600	0.091	0.102
E1	3.940	4.250	0.155	0.167
e	1.500 TYP		0.060TYP	
e1	3.000 TYP		0.118TYP	
L	0.900	1.200	0.035	0.047

TO-92 PACKAGE OUTLINE DIMENSIONS

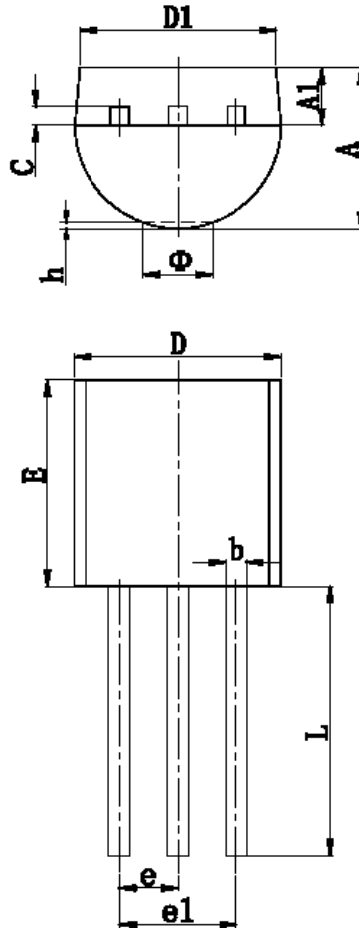

Symbol	Dimensions In Millimeters		Dimensions In Inches	
	Min	Max	Min	Max
A	3.300	3.700	0.130	0.146
A1	1.100	1.400	0.043	0.055
b	0.380	0.550	0.015	0.022
c	0.360	0.510	0.014	0.020
D	4.400	4.700	0.173	0.185
D1	3.430		0.135	
E	4.300	4.700	0.169	0.185
e	1.270 TYP		0.050 TYP	
e1	2.440	2.640	0.096	0.104
L	14.100	14.500	0.555	0.571
Φ		1.600		0.063
h	0.000	0.380	0.000	0.015