

Ultralow-Noise, High PSRR, Fast RF Low-Dropout CMOS Voltage Regulator

■ **INTRODUCTION**

The FC6300 series are a group of positive voltage regulators manufactured by CMOS technologies with high ripple rejection, ultra low noise, low power consumption and low dropout voltage, which can prolong battery life in portable electronics. The FC6300 series work with low-ESR ceramic capacitors, reducing the amount of board space necessary for power applications. The FC6300 series consume less than 0.1µA in shutdown mode and have fast turn-on time less than 50µs. The series are very suitable for the battery-powered equipments, such as RF applications and other systems requiring a quiet voltage source.

■ **FEATURES**

- 500mA RF Low-Dropout Regulator With Enable
- Ultralow-Noise: 40µV_{RMS}(10Hz~100kHz)
- High PSRR: 70dB@1kHz
- Fast Start-Up Time (20µs)
- Excellent Load/Line Transient Response
- Low Dropout Voltage: 110mV@100mA
- Stable With a 1µF Ceramic Capacitor
- Available in Adjustable Voltage Version (0.6V to 5.5V)
- Built-in Current Limiter, Short-Circuit Protection

■ **APPLICATIONS**

- RF: VCOs, Receivers, ADCs
- Cellular and Cordless Telephones
- Handheld Organizers
- Audio
- Bluetooth, Wireless LAN
- Tablet, MID

■ **BLOCK DIAGRAM**

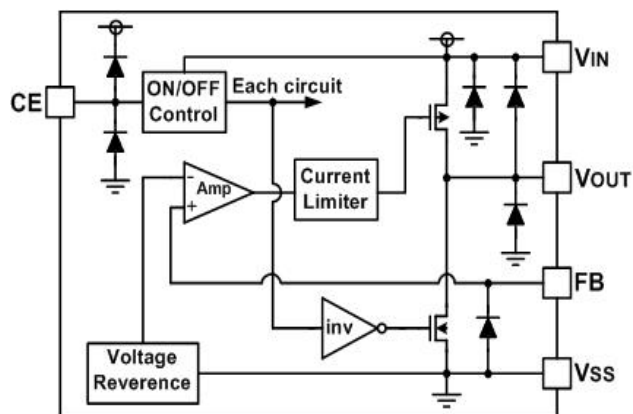

■ **ORDER INFORMATION**

FC6300 ①②

DESIGNATOR	SYMBOL	DESCRIPTION
①	B	High Active, pull-down resistor built in, with C _{OUT} discharge resistor
②	M/E	Package: SOT-23-5L/6L
	N	Package: WBHFBP-06L

PIN CONFIGURATION

SOT-23-5L

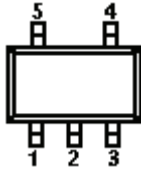

SOT-23-6L



WBHFBP-06L

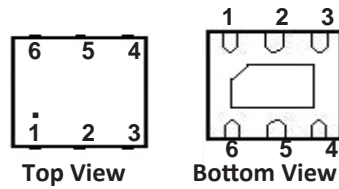

SOT-23-5L

PIN NUMBER		PIN NAME	FUNCTION
M			
1		V_{IN}	Power input Pin
2		V_{SS}	Ground
3		CE	Chip Enable Pin
4		FB	Feedback Pin: Used to Set Output Voltage
5		V_{OUT}	Output Pin

SOT-23-6L/WBHFBP-06L

PIN NUMBER		PIN NAME	FUNCTION
E	N		
1	3	V_{IN}	Power input Pin
2	2	V_{SS}	Ground
3	1	CE	Chip Enable Pin
5	6	FB	Feedback Pin: Used to Set Output Voltage
6	4	V_{OUT}	Output Pin
4	5	NC	Not Connection
-	7		Thermal Pad

TYPICAL APPLICATION

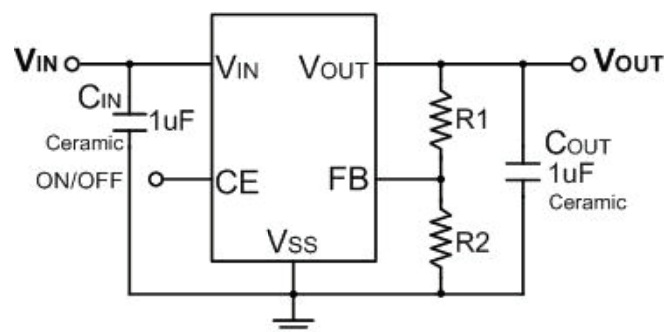

Fig.1 Typical Application Circuit



FC6300

Electrical Characteristics

■ ABSOLUTE MAXIMUM RATINGS (T_A=25°C, Unless otherwise specified)

PARAMETER		SYMBOL	RATINGS	UNITS
Input Voltage		V _{IN}	V _{SS} -0.3~V _{SS} +8	V
Output Current		I _{OUT}	750	mA
Output Voltage		V _{OUT}	V _{SS} -0.3~V _{IN} +0.3	V
Power Dissipation	SOT-23-5L	P _d	400	mW
	SOT-23-6L	P _d	400	mW
	WBHFBP-06L	P _d	300	mW
Operating Ambient Temperature		T _A	-40~+85	°C
Operating Junction Temperature		T _j	-40~+125	°C
Storage Temperature		T _{stg}	-40~+125	°C
Soldering Temperature & Time		T _{solder}	260°C, 10s	

■ ELECTRICAL CHARACTERISTICS

(V_{IN}=V_{OUT}+1V, C_{IN}=C_{OUT}=1μF, T_A=25°C, unless otherwise specified)

PARAMETER	SYMBOL	CONDITIONS	MIN.	TYP.	MAX.	UNITS
Input Voltage	V _{IN}	—	1.8 ⁽¹⁾		7.0	V
Output Current	I _{OUT}	V _{OUT} ≥ 1.8V	500			mA
Supply Current	I _{SS}	I _{OUT} =0mA		45	80	μA
Standby Current	I _{STBY}	V _{CE} =0V			0.1	μA
CE "High" Voltage	V _{CEH}		1.2		V _{IN}	V
CE "Low" Voltage	V _{CEL}				0.3	V
CE pin current		V _{CE} =0V	-1		1	μA
FB Voltage	V _{FB}	I _{OUT} =1mA	0.588	0.600	0.612	V
FB pin current		V _{FB} =1.8V			1	μA
Output voltage range			0.6		5.5 - V _{DO}	V
Line Regulation	$\frac{\Delta V_{OUT}}{V_{OUT} \times \Delta V_{IN}}$	I _{OUT} =10mA V _{OUT} +1V ≤ V _{IN} ≤ 7V		0.01	0.2	%/V
Load Regulation	ΔV _{OUT}	V _{IN} = V _{OUT} +1V, 1mA ≤ I _{OUT} ≤ 100mA		1		mV
Dropout Voltage ⁽²⁾	V _{dif}	I _{OUT} =100mA V _{OUT} ≥ 3.0V		110		mV
Output Voltage Temperature Characteristics	$\frac{\Delta V_{OUT}}{\Delta T \times V_{OUT}}$	I _{OUT} =10mA -40 ≤ T ≤ +85		50		ppm
Current Limit	I _{LM}		600	750		mA
Short Current	I _{SHORT}	V _{OUT} =V _{SS}		20		mA
Power Supply Ripple Rejection	V _{OUT} =1.2V	PSRR	f=100Hz, I _{OUT} =50mA	80		dB
			f=1kHz, I _{OUT} =50mA	70		
			f=10kHz, I _{OUT} =50mA	50		
Output noise voltage		BW=10Hz to 100kHz, I _{OUT} =10mA		40		μV _{RMS}
Time, start-up		I _{OUT} =0mA, C _{OUT} =1μF		20		μS

Electrical Characteristics(Continued)

NOTE:

- (1) Minimum V_{IN} is 1.8V or $V_{OUT} + V_{DO}$, whichever is greater.
- (2) V_{dif} : The difference of output voltage and input voltage when input voltage is decreased gradually till output voltage equals to 98% of V_{OUT} (E).

■ DROPOUT VOLTAGE CHART

Setting Output Voltage	Dropout Voltage (mV) Typ.			
$V_{OUT}(V)$	$I_{OUT}=100mA$	$I_{OUT}=200mA$	$I_{OUT}=300mA$	$I_{OUT}=500mA$
1.2	380mV	640mV	880mV	
1.5	250mV	480mV	680mV	
1.8	190mV	380mV	570mV	950mV
2.1	155mV	310mV	470mV	820mV
2.5	130mV	260mV	400mV	700mV
2.8	120mV	240mV	360mV	640mV
3.0	110mV	230mV	350mV	610mV
3.3	105mV	210mV	320mV	570mV
3.6	100mV	200mV	310mV	540mV
4.0	95mV	185mV	290mV	500mV
4.5	90mV	180mV	280mV	470mV
5.0	85mV	170mV	260mV	440mV

■ TYPICAL PERFORMANCE CHARACTERISTICS

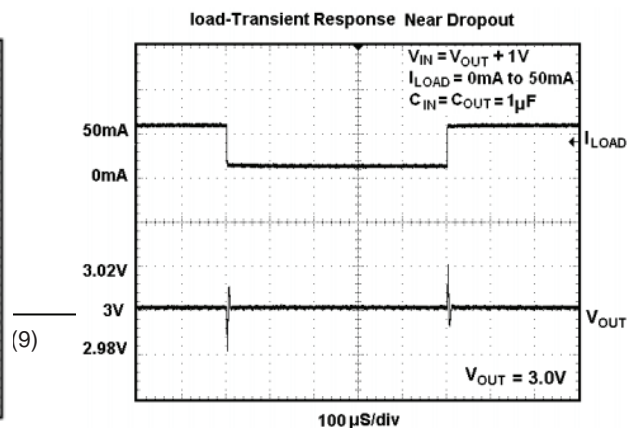
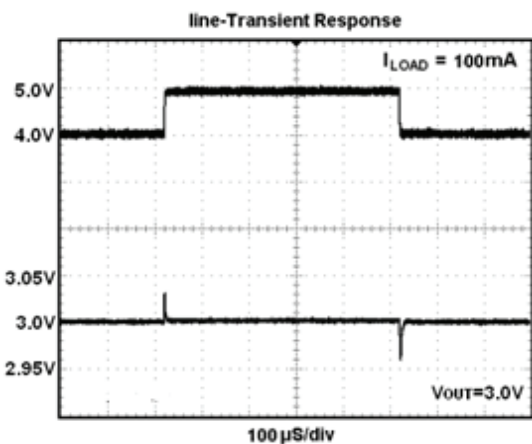
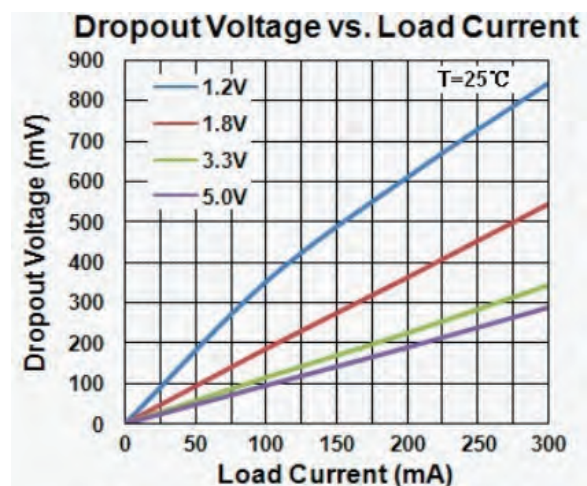
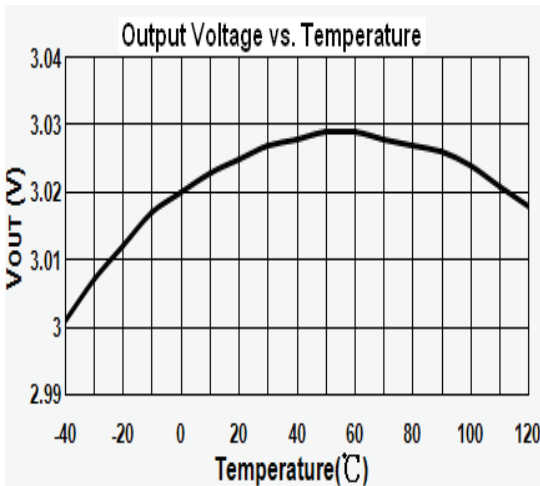

Typical Characteristics (Continued)

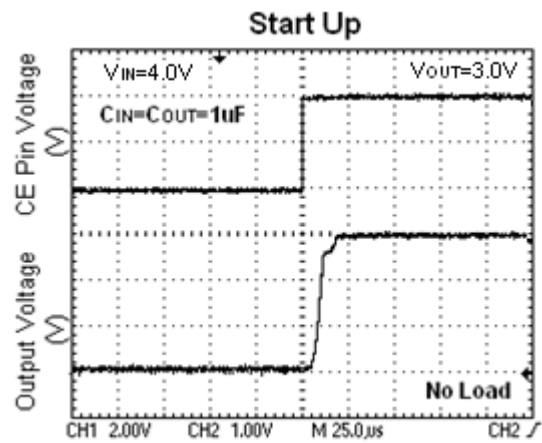
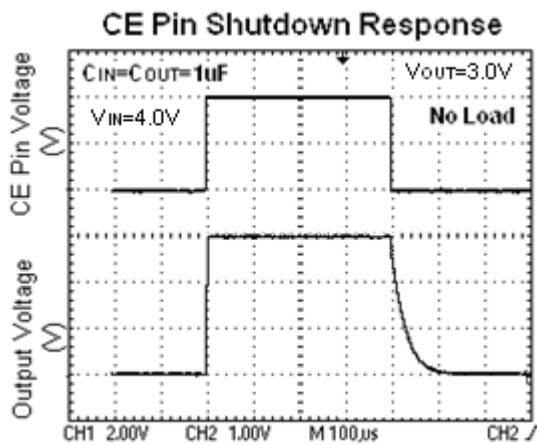
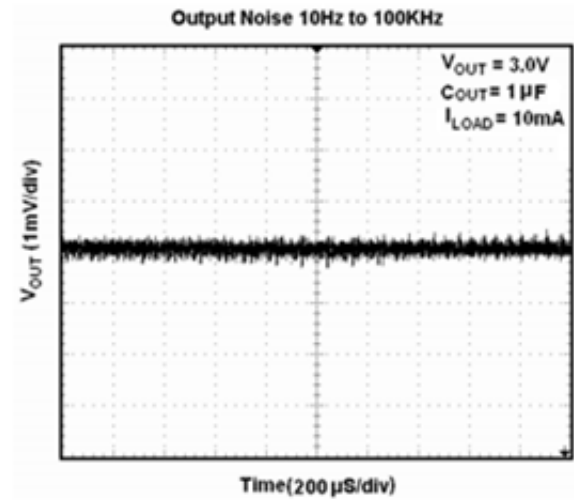
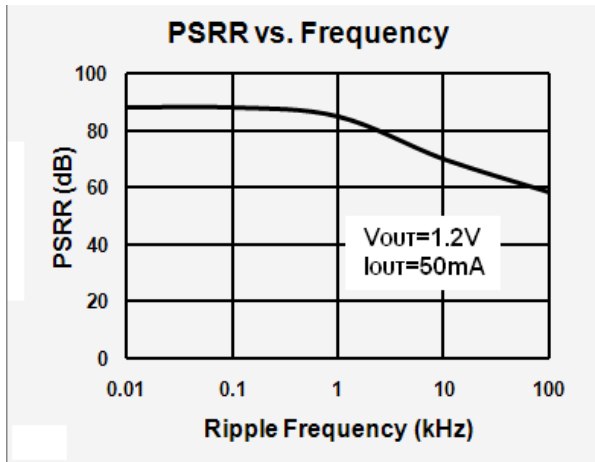

■ APPLICATION INFORMATION

Setting The Output Voltage

Figure 1 shows the typical application circuit with FC6300. The external resistor sets the output voltage according to the following equation:

$$V_{OUT} = 0.6V \times \left(1 + \frac{R1}{R2}\right)$$

Table 1. Resistor select for output voltage setting

V_{OUT}	R1	R2
1.2V	30.1K	30.1K
1.5V	45.3K	30.1K
1.8V	60.4K	30.1K
2.5V	95.3K	30.1k
2.8V	110K	30.1k
3.0V	120K	30.1K
3.3V	137K	30.1K
5.0V	221K	30.1k

SOT-23-5L Package Outline Dimensions

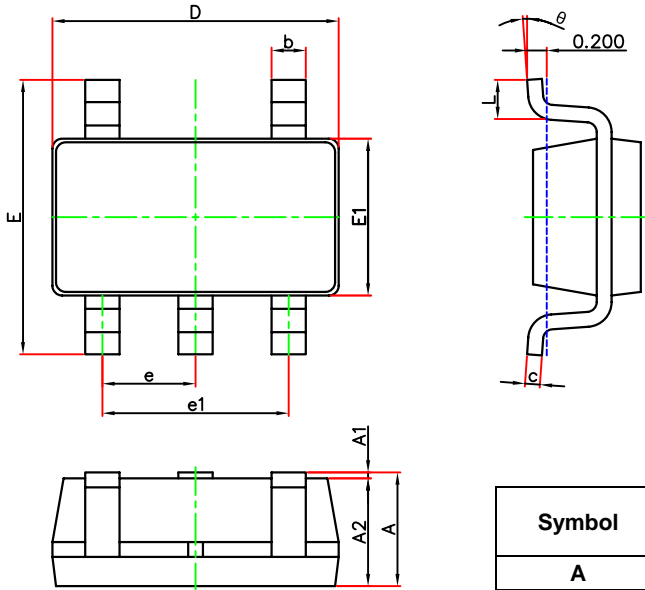

Symbol	Dimensions In Millimeters		Dimensions In Inches	
	Min.	Max.	Min.	Max.
A	1.050	1.250	0.041	0.049
A1	0.000	0.100	0.000	0.004
A2	1.050	1.150	0.041	0.045
b	0.300	0.500	0.012	0.020
c	0.100	0.200	0.004	0.008
D	2.820	3.020	0.111	0.119
E	2.650	2.950	0.104	0.116
E1	1.500	1.700	0.059	0.067
e	0.950(BSC)		0.037(BSC)	
e1	1.800	2.000	0.071	0.079
L	0.300	0.600	0.012	0.024
θ	0°	8°	0°	8°

SOT-23-5L Suggested Pad Layout

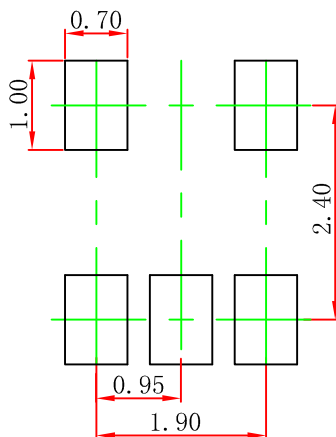

Note:

1. Controlling dimension: in millimeters.
2. General tolerance: $\pm 0.05\text{mm}$.
3. The pad layout is for reference purposes only.

SOT-23-6L Package Outline Dimensions

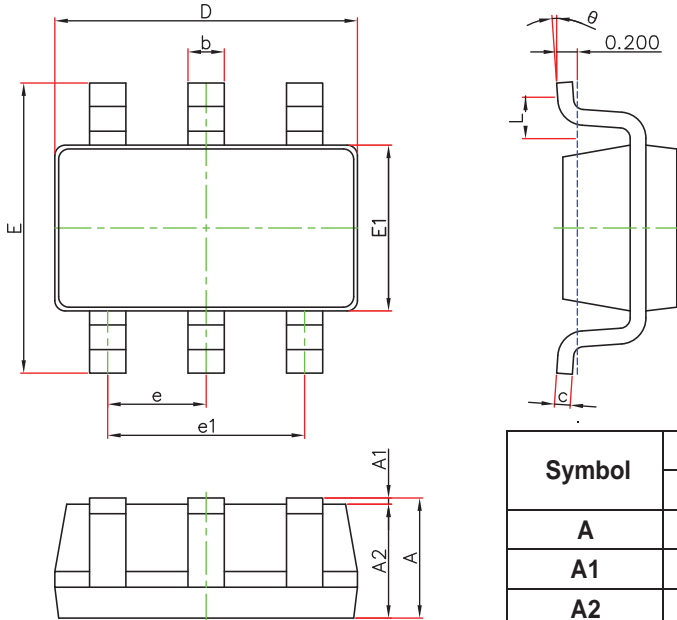

Symbol	Dimensions In Millimeters		Dimensions In Inches	
	Min	Max	Min	Max
A	1.050	1.250	0.041	0.049
A1	0.000	0.100	0.000	0.004
A2	1.050	1.150	0.041	0.045
b	0.300	0.500	0.012	0.020
c	0.100	0.200	0.004	0.008
D	2.820	3.020	0.111	0.119
E	2.650	2.950	0.104	0.116
E1	1.500	1.700	0.059	0.067
e	0.950(BSC)		0.037(BSC)	
e1	1.800	2.000	0.071	0.079
L	0.300	0.600	0.012	0.024
theta	0°	8°	0°	8°

SOT-23-6L Suggested Pad Layout

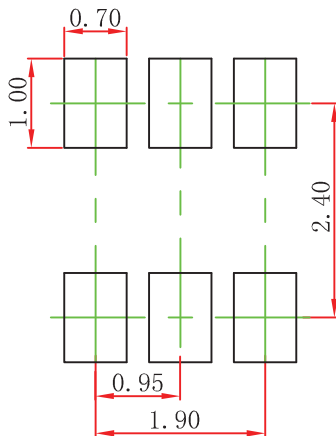

Note:
 1. Controlling dimension: in millimeters.
 2. General tolerance: ± 0.05 mm.
 3. The pad layout is for reference purposes only.

WBHFBP-06L Package Outline Dimensions

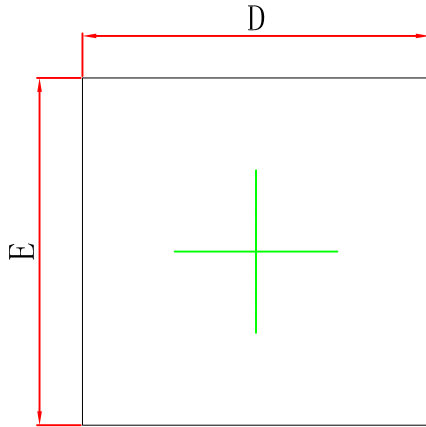

Top View

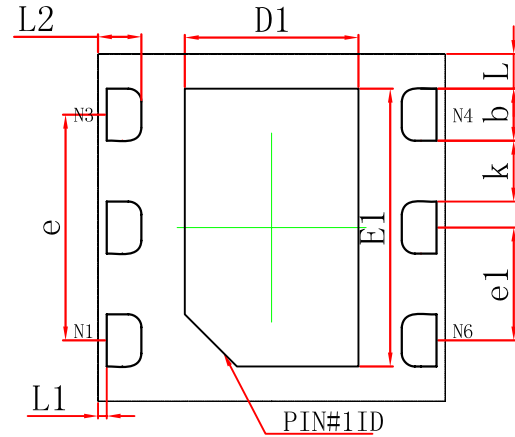

Bottom View

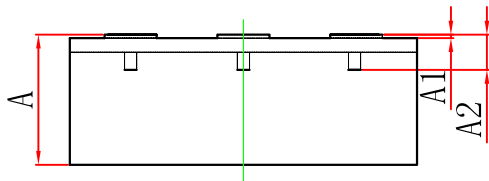

Side View

Symbol	Dimensions In Millimeters		Dimension In Inches	
	Min.	Max.	Min.	Max.
A	0.700	0.800	0.028	0.031
A1	0.000	0.050	0.000	0.002
A2	0.203REF		0.008REF	
D	1.950	2.050	0.077	0.081
E	1.950	2.050	0.077	0.081
D1	0.950	1.050	0.037	0.041
E1	1.550	1.650	0.061	0.065
b	0.250	0.350	0.010	0.014
e	1.300REF		0.051REF	
e1	0.650BSC		0.026BSC	
k	0.350REF		0.014REF	
L	0.200REF		0.008REF	
L1	0.050REF		0.002REF	
L2	0.200	0.300	0.008	0.012