

## High PSRR 1A CMOS Voltage Regulators

### ■ INTRODUCTION

The FC6107 Series are a group of positive voltage regulators manufactured by CMOS technology with high ripple rejection, ultra-fast transient response and low dropout voltage, which provide large output currents even when the difference of the input-output voltage is small. Each of the FC6107 series consists of a high-precision voltage reference, an error correction circuit, and a current limited output driver. Thus the series are very suitable for the battery-powered equipments, wireless communication applications, industry equipments and so on.

### ■ APPLICATIONS

- Battery powered systems
- Portable instrumentations

### ■ BLOCK DIAGRAM

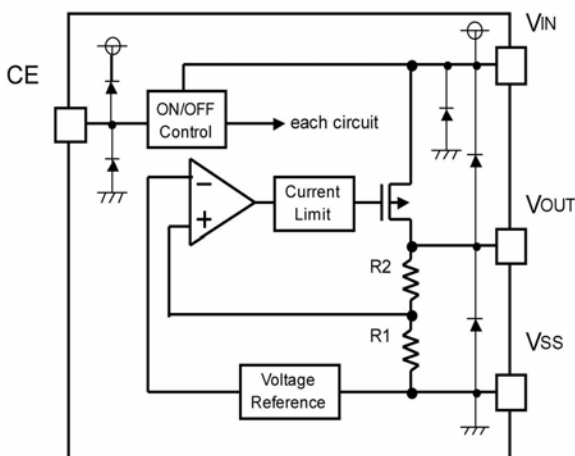

### ■ FEATURES

- Guaranteed Output Current: 1.0A(Typ.)
- Low Quiescent Current: 70 $\mu$ A (Typ.)
- Output Voltage Range: 1.5V~5.0V
- Input Voltage Range: 2.5V~6.0V
- High Accuracy:  $\pm 2\%$  (Typ.)
- Dropout Voltage:  
500mV@1.0A (3.0V Typ.)
- Excellent Line Regulation: 0.02%/V
- High PSRR : 70dB@1KHz
- Built-in Current Limiter & Thermal Protection
- Short Circuit Current Fold-back
- Output Capacitor: Ceramic Compatible

- GRS Receivers
- Wireless devices

### ■ ORDER INFORMATION

#### FC6107①②③④

DESIGNATOR	SYMBOL	DESCRIPTION
①	A	Standard
	B	With Shutdown Function
②③	Integer	Output Voltage(0.8~5.0V) e.g:3.0V=②:3, ③:0
④	M	Package:SOT-23-5L
	P/PL	Package:SOT-89-3L
	G	Package:SOT-223
	FB	Package:WBHFBP-06L

■ **PIN CONFIGURATION** (Pin output sequence can be ordered by customer)

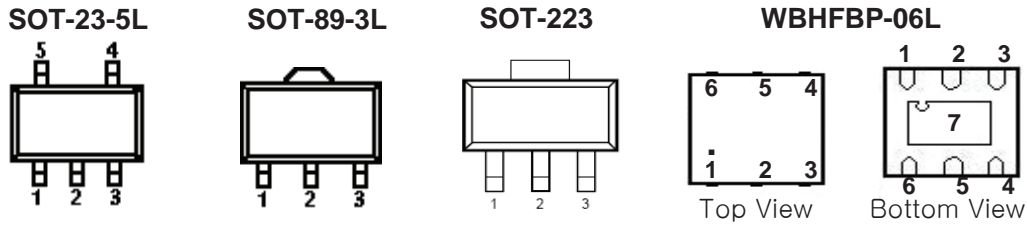

PIN NUMBER			PIN NAME	FUNCTION
SOT-223	SOT-89-3L			
<b>G</b>	<b>P</b>	<b>PL</b>		
1	1	2	$V_{SS}$	Ground
2	2	1	$V_{IN}$	Power input
3	3	3	$V_{OUT}$	Output

**SOT-23-5L/WBHFBP-06L**

PIN NUMBER		SYMBOL	FUNCTION
<b>M</b>	<b>FB</b>		
1	3	$V_{IN}$	Power Input Pin
2	2	$V_{SS}$	Ground
3	1	CE	Chip Enable Pin
4	5	NC	No Connection
5	4	$V_{OUT}$	Output Pin
-	6	NC	No Connection
-	7		Thermal Pad

■ **ABSOLUTE MAXIMUM RATINGS** ( $T_a=25^{\circ}\text{C}$ , Unless otherwise specified)

PARAMETER	SYMBOL	RATINGS	UNITS
Input Voltage	$V_{IN}$	$V_{SS}-0.3\sim V_{SS}+7$	V
Output Current	$I_{OUT}$	1100	mA
Output Voltage	$V_{OUT}$	$V_{SS}-0.3\sim V_{IN}+0.3$	V
Power Dissipation	SOT-89-3L	$P_d$	600
	SOT-23-5L	$P_d$	400
	WBHFBP-06L	$P_d$	600
	SOT-223	$P_d$	800
Operating Temperature	$T_{opr}$	-40~+85	$^{\circ}\text{C}$
Storage Temperature	$T_{stg}$	-40~+125	$^{\circ}\text{C}$
Soldering Temperature & Time	$T_{solder}$	260 $^{\circ}\text{C}$ , 10s	



# FC6107 Series

## ELECTRICAL CHARACTERISTICS

( $V_{IN}=V_{OUT}+1V$ ,  $C_{IN}=C_{OUT}=1\mu F$ ,  $T_A=25^\circ C$ , unless otherwise specified)

PARAMETER	SYMBOL	CONDITIONS	MIN	TYP	MAX	UNITS
Output Voltage	$V_{OUT(E)}$ (Note 2)	$I_{OUT}=100mA$	$V_{OUT}$ *0.98	$V_{OUT}$ (Note 1)	$V_{OUT}$ *1.02	V
Supply Current	$I_{SS}$			70		$\mu A$
Shutdown Current	$I_{SHDN}$	$V_{CE}=V_{SS}$		0.1	1.0	$\mu A$
Output Current	$I_{OUT}$	—		1000		mA
Dropout Voltage (Note 3)	$V_{dif1}$	$I_{OUT} = 300mA$		150		mV
	$V_{dif2}$	$I_{OUT} = 1000mA$		500		mV
Load Regulation	$\Delta V_{OUT}$	$V_{IN}= V_{OUT} + 1V$ , $1mA \leq I_{OUT} \leq 1.0A$		30		mV
Line Regulation	$\frac{\Delta V_{OUT}}{\Delta V_{IN} * V_{OUT}}$	$I_{OUT} = 100mA$ $V_{OUT} + 1V \leq V_{IN} \leq 6V$		0.02	0.2	%/V
Output Voltage Temperature Characteristics	$\frac{\Delta V_{OUT}}{\Delta T * V_{OUT}}$	$I_{OUT} = 100mA$ $-40^\circ C \leq T \leq +85^\circ C$		50		ppm/ $^\circ C$
Short Current	$I_{Short}$	$V_{OUT} = V_{SS}$		200		mA
Input Voltage	$V_{IN}$	—	2.5		6.0	V
Power Supply Rejection Rate	1KHz	PSRR	$I_{OUT}=100mA$	70		dB
	10KHz			50		
CE "High" Voltage	$V_{CE} "H"$		1.5		$V_{IN}$	V
CE "Low" Voltage	$V_{CE} "L"$				0.3	V
Thermal Shutdown Temperature	$T_{SD}$			150		$^\circ C$
Thermal Shutdown Temperature Hysteresis	$\Delta T_{SD}$			30		$^\circ C$

### NOTE:

1.  $V_{OUT}$ : Specified Output Voltage.
2.  $V_{OUT} (E)$  : Effective Output Voltage ( I.e. The Output Voltage When  $V_{IN} = (V_{OUT} + 1.0V)$  And Maintain A Certain  $I_{OUT}$  Value).
3.  $V_{dif}$ : The Difference Of Output Voltage And Input Voltage When Input Voltage Is Decreased Gradually Till Output Voltage Equals To 98% Of  $V_{OUT} (E)$ ; When  $V_{OUT} < 2.5V$ ,  $V_{IN} \geq 2.5V$  Should be Guaranteed.

## ■ TYPICAL APPLICATION CIRCUITS

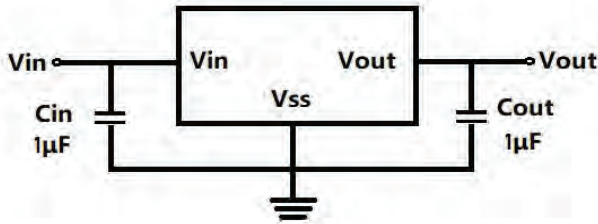

Figure1 FC6107A Typical Application Circuit

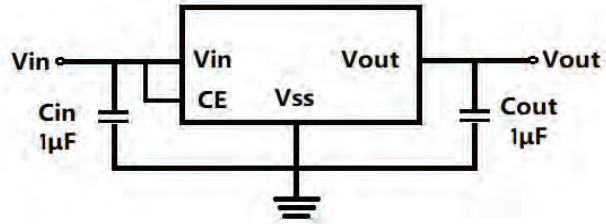

Figure2 FC6107B Typical Application Circuit

Input capacitor ( $C_{IN}$ ): 4.7 $\mu$ F or more;  
 Output capacitor ( $C_{OUT}$ ): 4.7 $\mu$ F or more;

**Caution:** A general series regulator may oscillate, depending on the external components selected. Check that no oscillation occurs with the application using the above capacitor.

## ■ TYPICAL PERFORMANCE CHARACTERISTICS

### (1) Input Transient Response

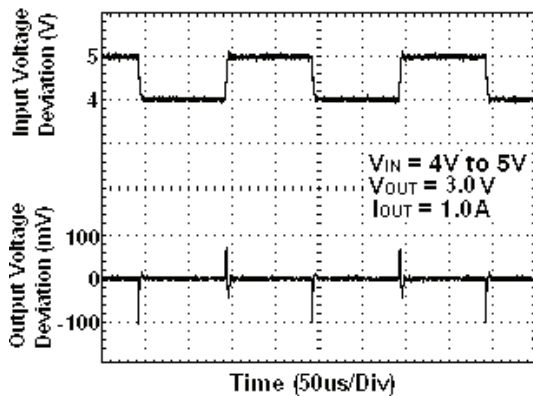

### (2) Load Transient Response

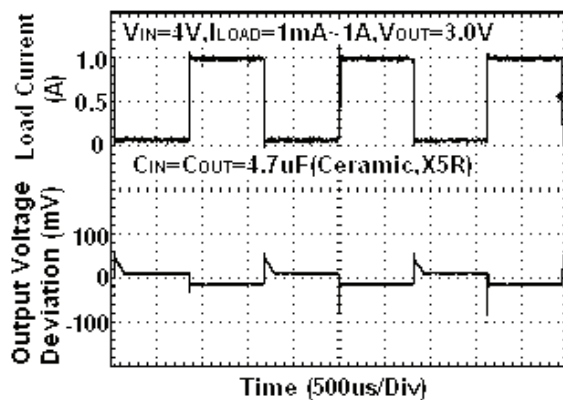

### (3) Output Voltage vs. Temperature

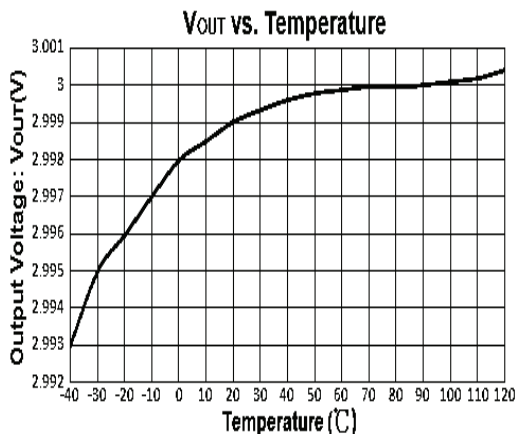

### (4) Power Supply Rejection Ratio

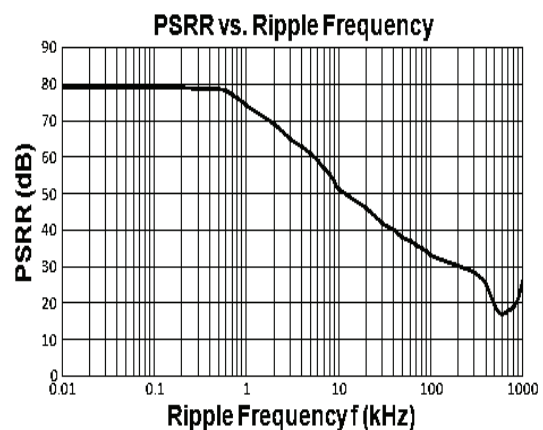



# FC6107 Series

## Typical Characteristics (Continued)

(3) Dropout Voltage vs. Output Current

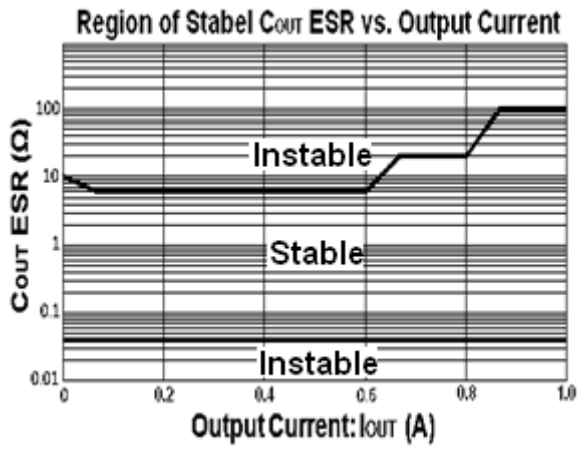

(4) Region of Stable  $C_{OUT}$  ESR vs. Load

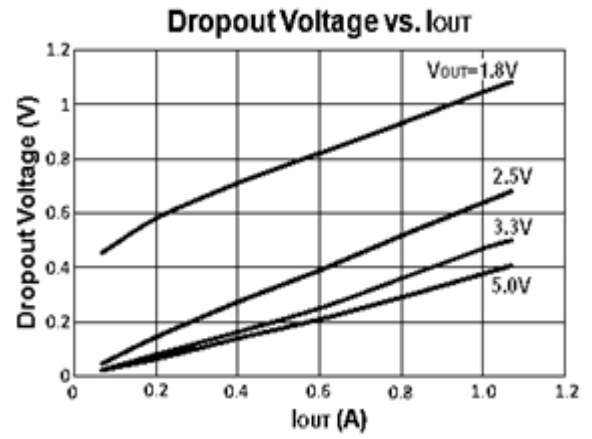

## SOT-89-3L Package Outline Dimensions

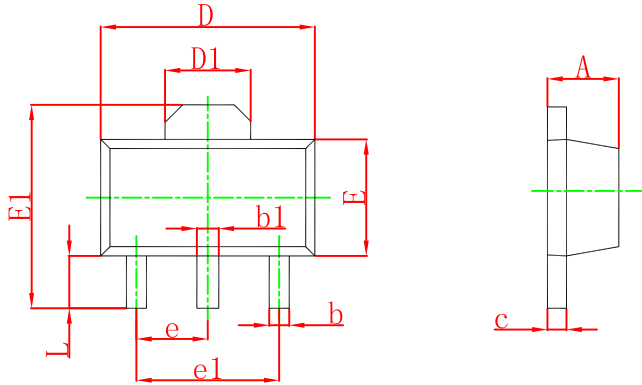

Symbol	Dimensions In Millimeters		Dimensions In Inches	
	Min.	Max.	Min.	Max.
A	1.400	1.600	0.055	0.063
b	0.320	0.520	0.013	0.197
b1	0.400	0.580	0.016	0.023
c	0.350	0.440	0.014	0.017
D	4.400	4.600	0.173	0.181
D1	1.550 REF		0.061 REF	
E	2.300	2.600	0.091	0.102
E1	3.940	4.250	0.155	0.167
e	1.500 TYP		0.060 TYP	
e1	3.000 TYP		0.118 TYP	
L	0.900	1.200	0.035	0.047

## SOT-89-3L Suggested Pad Layout

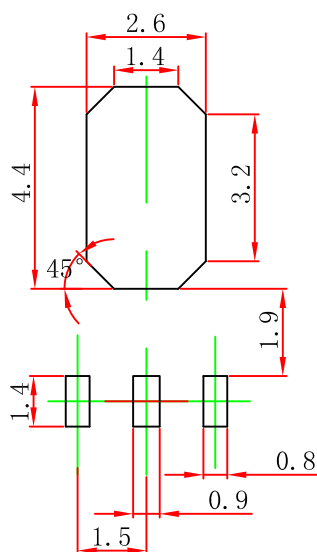

**Note:**

1. Controlling dimension: in millimeters.
2. General tolerance:  $\pm 0.05\text{mm}$ .
3. The pad layout is for reference purposes only.

## SOT-223 Package Outline Dimensions

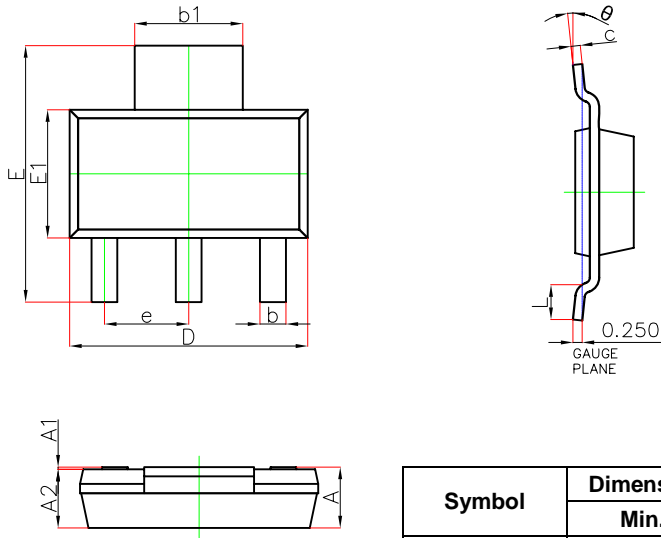

Symbol	Dimensions In Millimeters		Dimensions In Inches	
	Min.	Max.	Min.	Max.
A	—	1.800	—	0.071
A1	0.020	0.100	0.001	0.004
A2	1.500	1.700	0.059	0.067
b	0.660	0.840	0.026	0.033
b1	2.900	3.100	0.114	0.122
c	0.230	0.350	0.009	0.014
D	6.300	6.700	0.248	0.264
E	6.700	7.300	0.264	0.287
E1	3.300	3.700	0.130	0.146
e	2.300(BSC)		0.091(BSC)	
L	0.750	—	0.030	—
theta	0°	10°	0°	10°

## SOT-223 Suggested Pad Layout

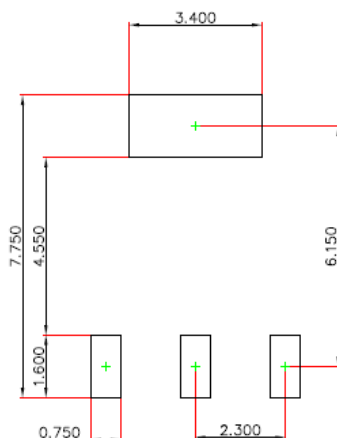

**Note:**

1. Controlling dimension: in millimeters.
2. General tolerance:  $\pm 0.050$ mm.
3. The pad layout is for reference purposes only.

## SOT-23-5L Package Outline Dimensions

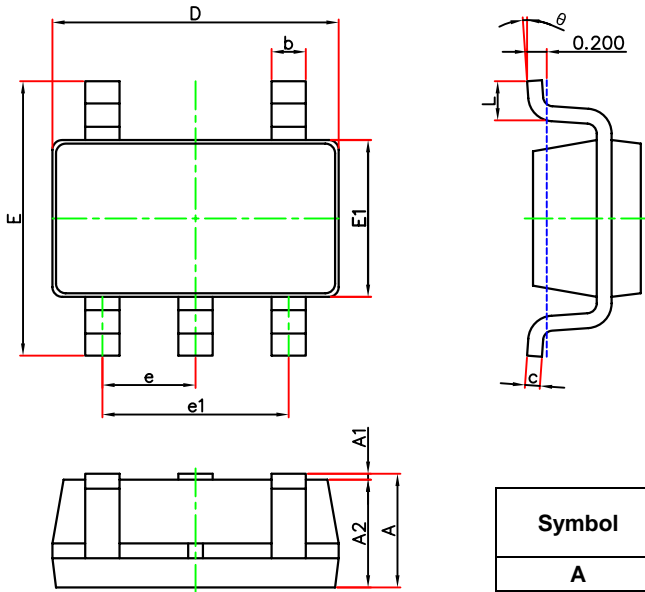

Symbol	Dimensions In Millimeters		Dimensions In Inches	
	Min.	Max.	Min.	Max.
A	1.050	1.250	0.041	0.049
A1	0.000	0.100	0.000	0.004
A2	1.050	1.150	0.041	0.045
b	0.300	0.500	0.012	0.020
c	0.100	0.200	0.004	0.008
D	2.820	3.020	0.111	0.119
E	1.500	1.700	0.059	0.067
E1	2.650	2.950	0.104	0.116
e	0.950(BSC)		0.037(BSC)	
e1	1.800	2.000	0.071	0.079
L	0.300	0.600	0.012	0.024
θ	0°	8°	0°	8°

## SOT-23-5L Suggested Pad Layout

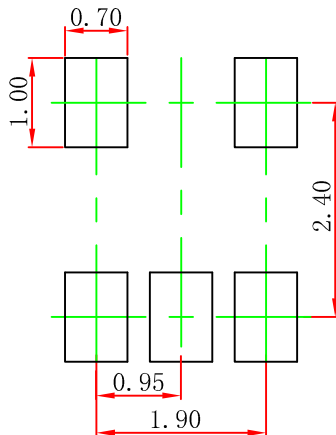

Note:

1. Controlling dimension: in millimeters.
2. General tolerance:  $\pm 0.05\text{mm}$ .
3. The pad layout is for reference purposes only.



## WBHFBP-06L Package Outline Dimensions

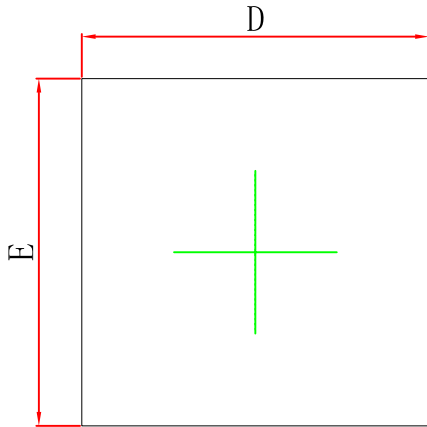

Top View

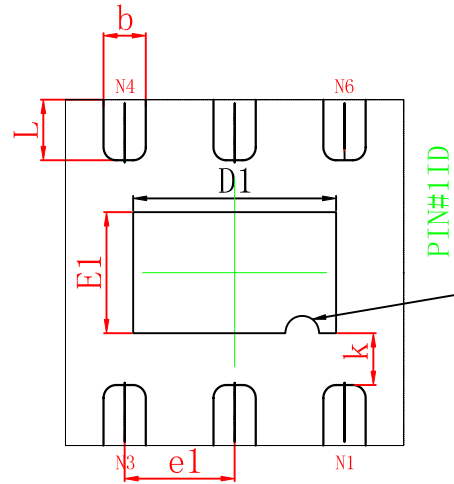

Bottom View

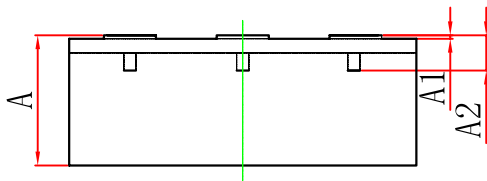

Side View

Symbol	Dimensions In Millimeters		Dimension In Inches	
	Min.	Max.	Min.	Max.
A	0.700	0.800	0.028	0.031
A1	0.000	0.050	0.000	0.002
A2	0.203REF		0.008REF	
D	1.950	2.050	0.077	0.081
E	1.950	2.050	0.077	0.081
D1	1.150	1.250	0.045	0.049
E1	0.650	0.750	0.026	0.030
b	0.200	0.300	0.008	0.012
e1	0.650TYP		0.026TYP	
k	0.200MIN		0.008MIN	
L	0.300	0.400	0.012	0.016