



White LED Step-up Converter

General Description

The FTD8203 is a current-mode and fixed frequency boost converter with an integrated N-FET to drive white LEDs.

The series connection allows the LED current to be identical for uniform brightness. Its low on-resistance of NFET and low feedback voltage reduce power loss and achieve high efficiency. Fast switching frequency(1.5MHz typical) allows using small-size inductor and both of input and output capacitors. An over voltage protection function, which monitors the output voltage via OVP pin, stops switching of the IC if the OVP voltage exceeds the over voltage threshold. An internal soft-start circuit eliminates the inrush current during start-up.

The FTD8203 also integrates under-voltage lockout, overtemperature protection, and current limit circuits to protect the IC in abnormal conditions. The FTD8203 is available in a SOT-23-6.

Features

- Wide Input Voltage from 2.7V to 6V
- Fixed 1.5MHz Switching Frequency
- Reference Voltage : 0.2V
- PWM Brightness Control with Wide Frequency
- Range of 100Hz to 100kHz
- Build-In Power MOSFET : 0.2Ω
- Open-LED Protection
- Under-Voltage Lockout Protection
- Over-Temperature Protection
- <1mA Quiescent Current during Shutdown
- SOT-23-6
- Halogen and Lead Free Available
- RoHS Compliant

Applications

- White LED Display Backlighting
- Cell Phone and Smart Phone
- PDA, PMP, MP3
- Digital Camera

White LED Step-up Converter

Pin Assignments

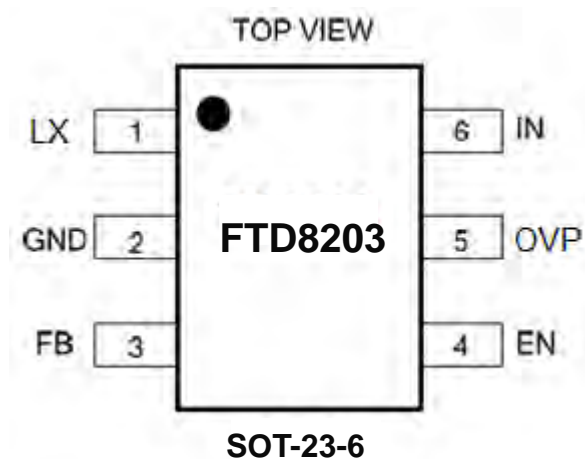

Pin Description

Pin Number	Pin Name	Description
1	LX	Switch pin. Connect this pin to inductor/diode here.
2	GND	Ground
3	FB	Feedback Pin. Connect this pin to cathode of the lowest LED and current-sense resistor (R1). Calculate resistor value according to $R1 = V_{REF} / I_{LED}$.
4	EN	Enable Control Input. Forcing this pin above 1.0V enables the device, or forcing this pin below 0.4V to shut it down. In shutdown, all functions are disabled to decrease the supply current below 1uA. Do not leave this pin floating.
5	OVP	Converter Output and Over-Voltage Protection Input Pin.
6	IN	Main Supply Pin. Must be closely decoupled to GND with a 4.7uF or greater ceramic capacitor.



FTD8203

White LED Step-up Converter

Ordering Information

FTD8203 □ □ □

Circuit Type

Packing:

Over-Voltage Threshold Code:

A-24V B-16V

Blank : Tube

Package

T:SOT-23-6

Functional Block Diagram

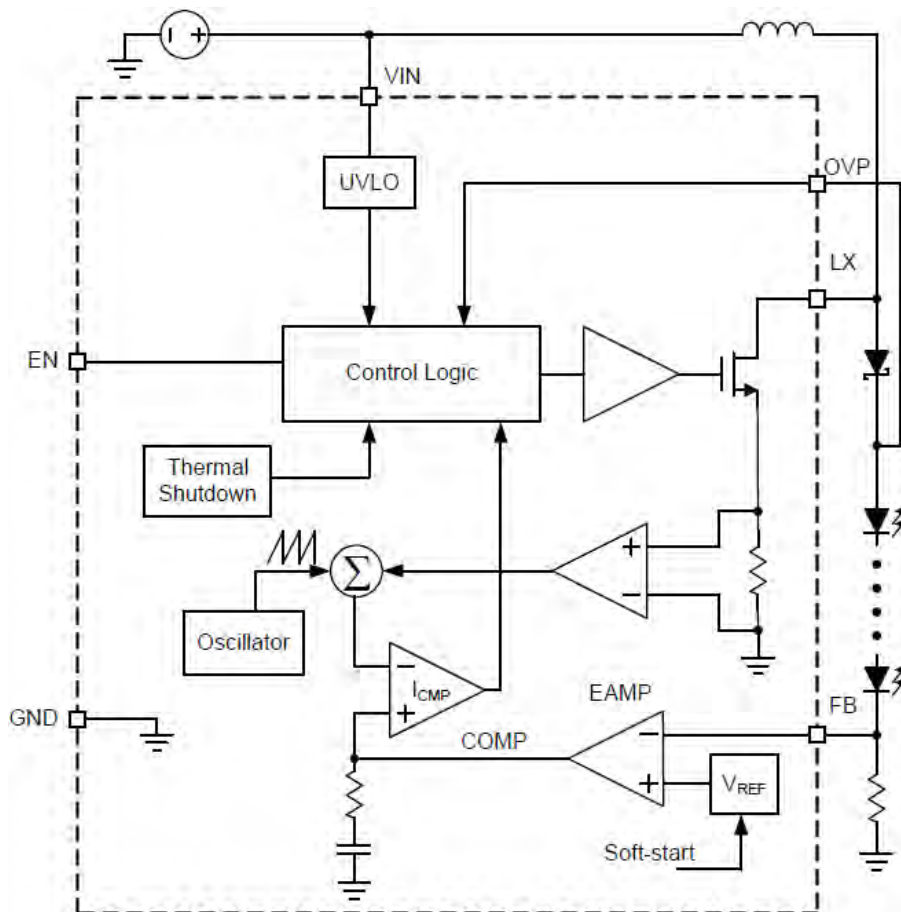

Functional Block Diagram of FTD8203



FTD8203

White LED Step-up Converter

Absolute Maximum Ratings

Symbol	Parameter	Rating	Unit
V _{IN}	V _{IN} Supply Voltage (V _{IN} to GND)	-0.3 ~ 7	V
V _{LX}	FB, EN to GND	-0.3 ~ V _{IN}	V
	LX to GND Voltage	-0.3 ~ 27.5	V
V _{OVP}	OVP to GND	-0.3 ~ 27.5	V
PD	Power Dissipation	Internally Limit	W
T _J	Maximum Junction Temperature	150	°C
T _{STG}	Storage Temperature	-65~150	°C
T _{SDR}	Maximum Lead Soldering Temperature, 10 Seconds	260	°C

Recommended Operating Conditions

Symbol	Parameter	Typical Value	Unit
θ _{JA}	Junction-to-Ambient Resistance in Free Air	220	°C/W
θ _{JC}	Junction-to-Case Resistance	120	°C/W
V _{IN}	V _{IN} Supply Voltage(V _{IN} to GND)	2.7-6	V
V _{OVP}	V _{OUT} to GND	V _{IN} -22	V
C _{IN}	Input Capacitor	4.7~	uF
C _{OUT}	Output Capacitor	4.7~	uF
L1	Converter Output Inductor	2.2-10	uH
T _A	Ambient Temperature	-40~85	°C
T _J	Junction Temperature	-40~125	°C



FTD8203

White LED Step-up Converter

Electrical Characteristics

The following specifications apply for $V_{IN}=3.6V$ ($T_A=25^\circ C$, unless specified otherwise.)

Symbol	Parameter	Test Conditions	FTD8203			Unit	
			Min.	Typ.	Max.		
V_{IN}	Input Voltage		2.5		6	V	
IDD1	Input DC Bias Current	$V_{FB}=0.4V$, no switching	-	300	-	μA	
IDD2		$V_{FB}=0V$, switching	-	2	5	mA	
ISD		EN=GND	-	-	1	μA	
	UVLO Threshold Voltage	V_{IN} Rising	2.0	2.2	2.4	V	
	UVLO Hysteresis Voltage	V_{IN} Falling	50	100	150	mV	
V_{REF}	Regulated Feedback Voltage	$V_{IN}=2.7V \sim 6V$, $T_A = 25^\circ C$	0.185	0.2	0.215	V	
		$V_{IN}=2.7V \sim 6V$, $T_A = -40 \sim 85^\circ C$	0.18		0.22		
I_{FB}	FB Input Current		-50		50	nA	
F_{SW}	Switching Frequency		1.25	1.5	1.75	MHz	
R_{ON}	Power Switch On Resistance			0.2		Ω	
I_{LIM}	Power Switch Current Limit			2		A	
	LX Leakage Current	$V_{EN} = 0V$, $V_{LX} = 0V$ or $6V$, $V_{IN} = 6V$	-1		1	μA	
D_{MAX}	LX Maximum Duty Cycle		92	95	98	%	
	Over Voltage Threshold	V_{OUT} Rising	FTD8203A	22	24	27.5	V
			FTD8203B	14.5	16	20	
	Over Voltage Hysteresis	V_{OVP} Falling	-	3	-	V	
	OVP Leakage	$V_{OVP} = 20V$	-	50	-	nA	
	Enable Voltage Threshold	V_{EN} Rising	1	-	-	V	
	Shutdown Voltage Threshold	V_{EN} Falling	-	-	0.4	V	
	EN Leakage Current	$V_{EN} = 0 \sim 6V$, $V_{IN} = 6V$	-2	-	2	μA	
	EN Minimum On Pluse Width	$V_{EN} = 0 \sim 6V$, $V_{IN} = 6V$, PWM	-	800	-	ns	
T_{OTP}	Over-Temperature Protection	T_J Rising		150		$^\circ C$	
	Over-Temperature Protection	T_J Falling		40		$^\circ C$	



White LED Step-up Converter

Typical Operating Characteristics

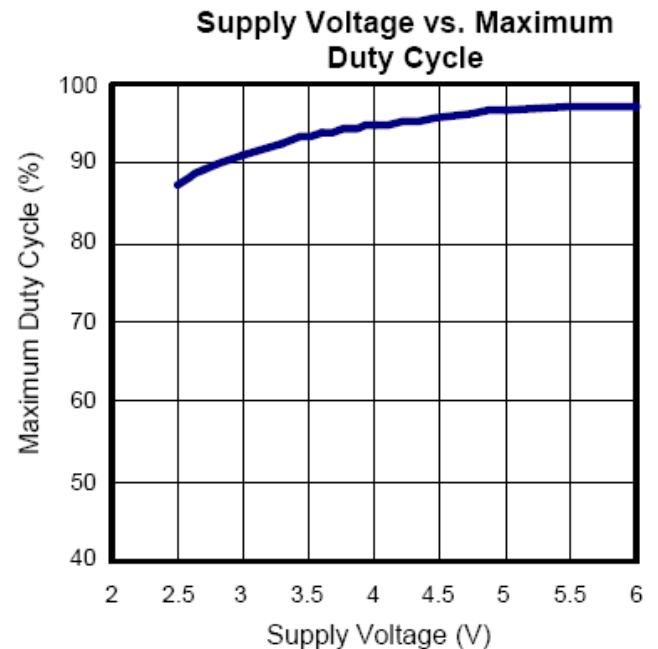
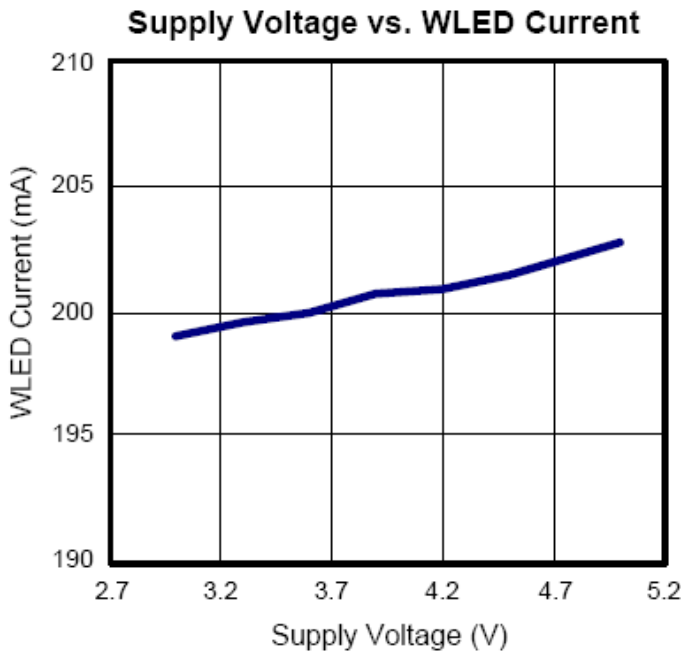
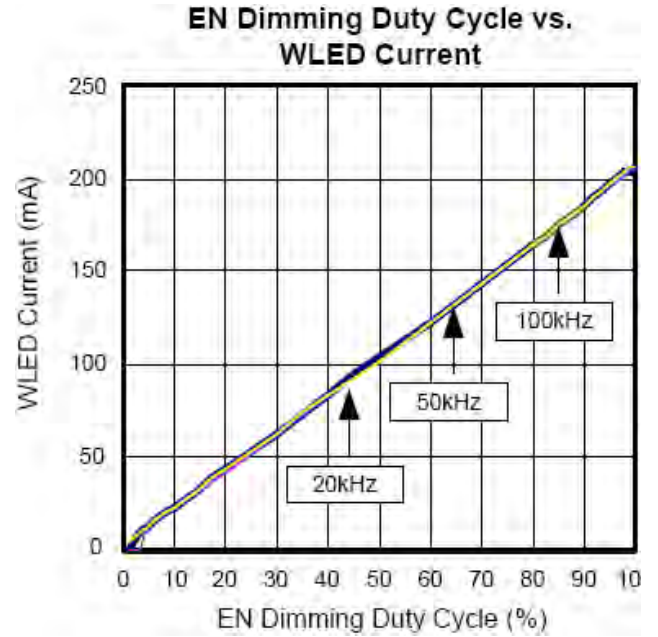
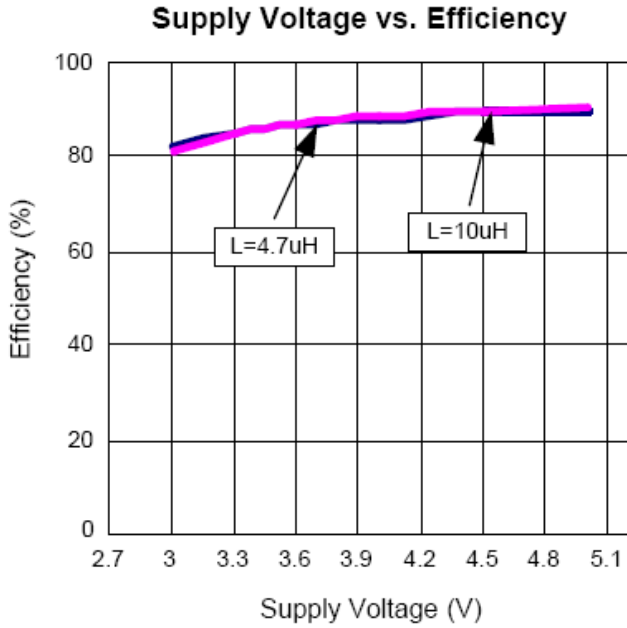

White LED Step-up Converter

Typical Operating Characteristics(Cont.)

Supply Voltage vs. Switch ON Resistance

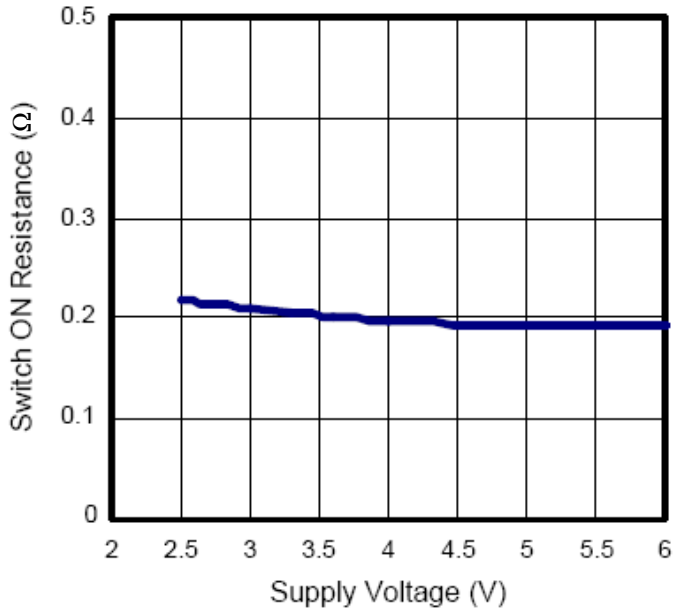

Operating Waveforms

EN Goes High- Enable

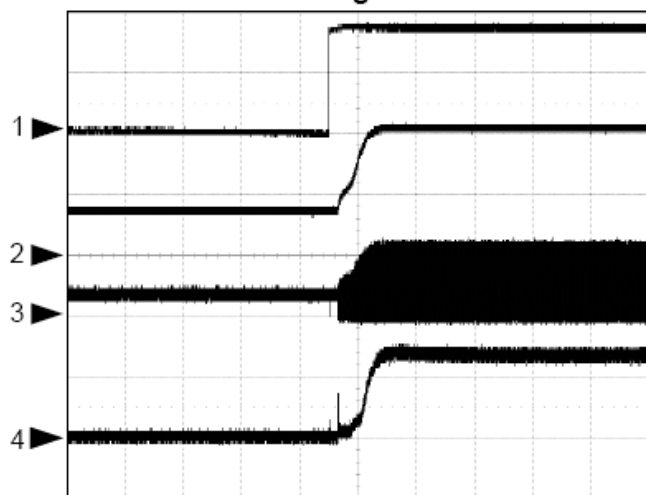

CH1: V_{EN} (2V/div)
 CH2: V_{OVP} (5V/div)
 CH3: V_{LX} (10V/div)
 CH4: I_{IN} (500mA/div)
 Time: 1ms/div

EN Goes Low- Shutdown

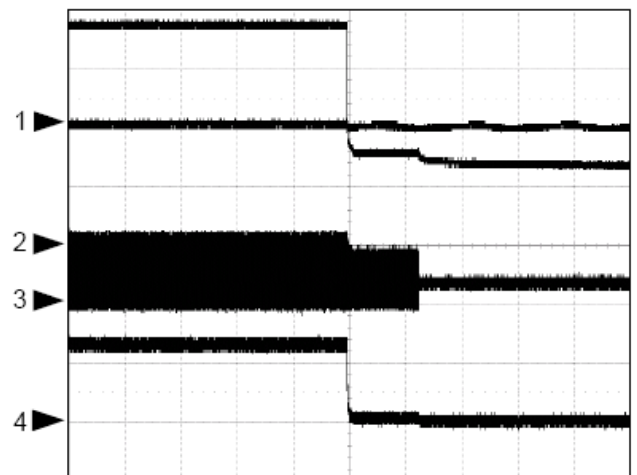

CH1: V_{EN} (2V/div)
 CH2: V_{OVP} (5V/div)
 CH3: V_{LX} (10V/div)
 CH4: I_{IN} (500mA/div)
 Time: 10ms/div

White LED Step-up Converter

Operating Waveforms(Cont.)

EN Goes High- Enable

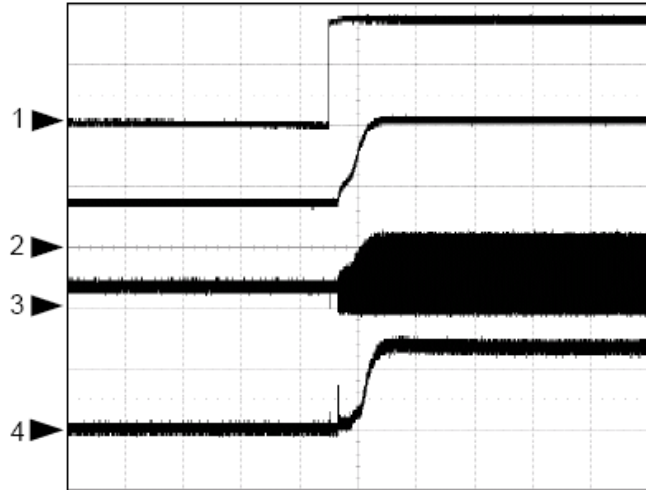

CH1: V_{EN} (2V/div)
 CH2: V_{OVP} (5V/div)
 CH3: V_{LX} (10V/div)
 CH4: I_{IN} (500mA/div)
 Time: 1ms/div

EN Goes Low- Shutdown

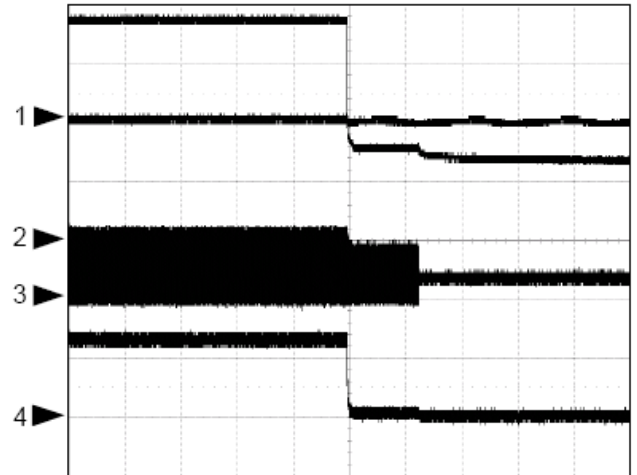

CH1: V_{EN} (2V/div)
 CH2: V_{OVP} (5V/div)
 CH3: V_{LX} (10V/div)
 CH4: I_{IN} (500mA/div)
 Time: 10ms/div

OPEN-LED Protection

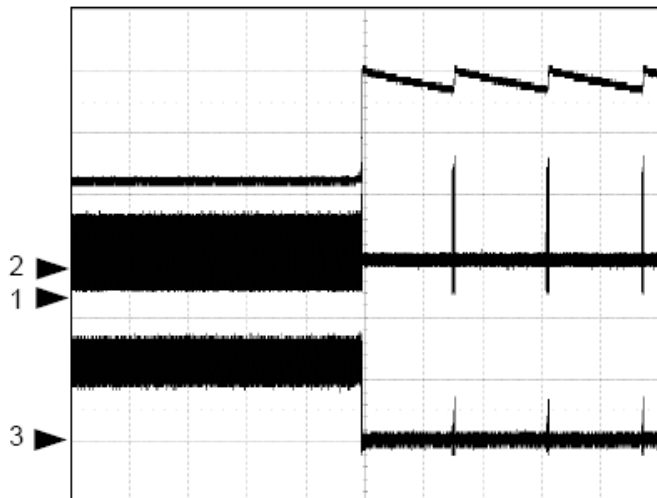

CH1: V_{OVP} (5V/div)
 CH2: V_{LX} (10V/div)
 CH3: I_L (500mA/div)
 Time: 10ms/div

Normal Operation

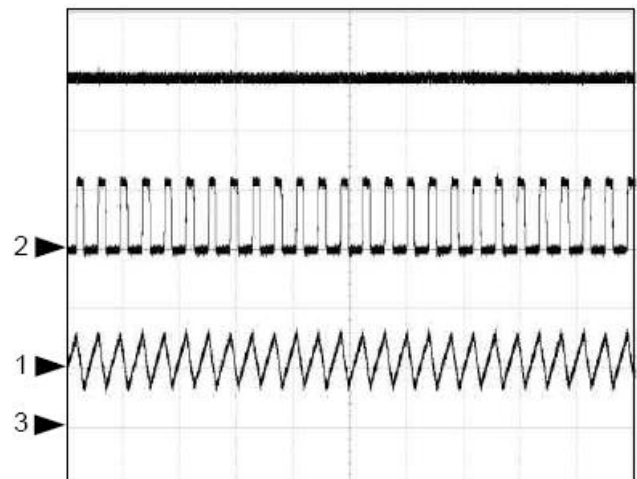

CH1: V_{OVP} (2V/div)
 CH2: V_{LX} (10V/div)
 CH3: I_L (500mA/div)
 Time: 2 μ s/div

White LED Step-up Converter

Typical Application Circuit

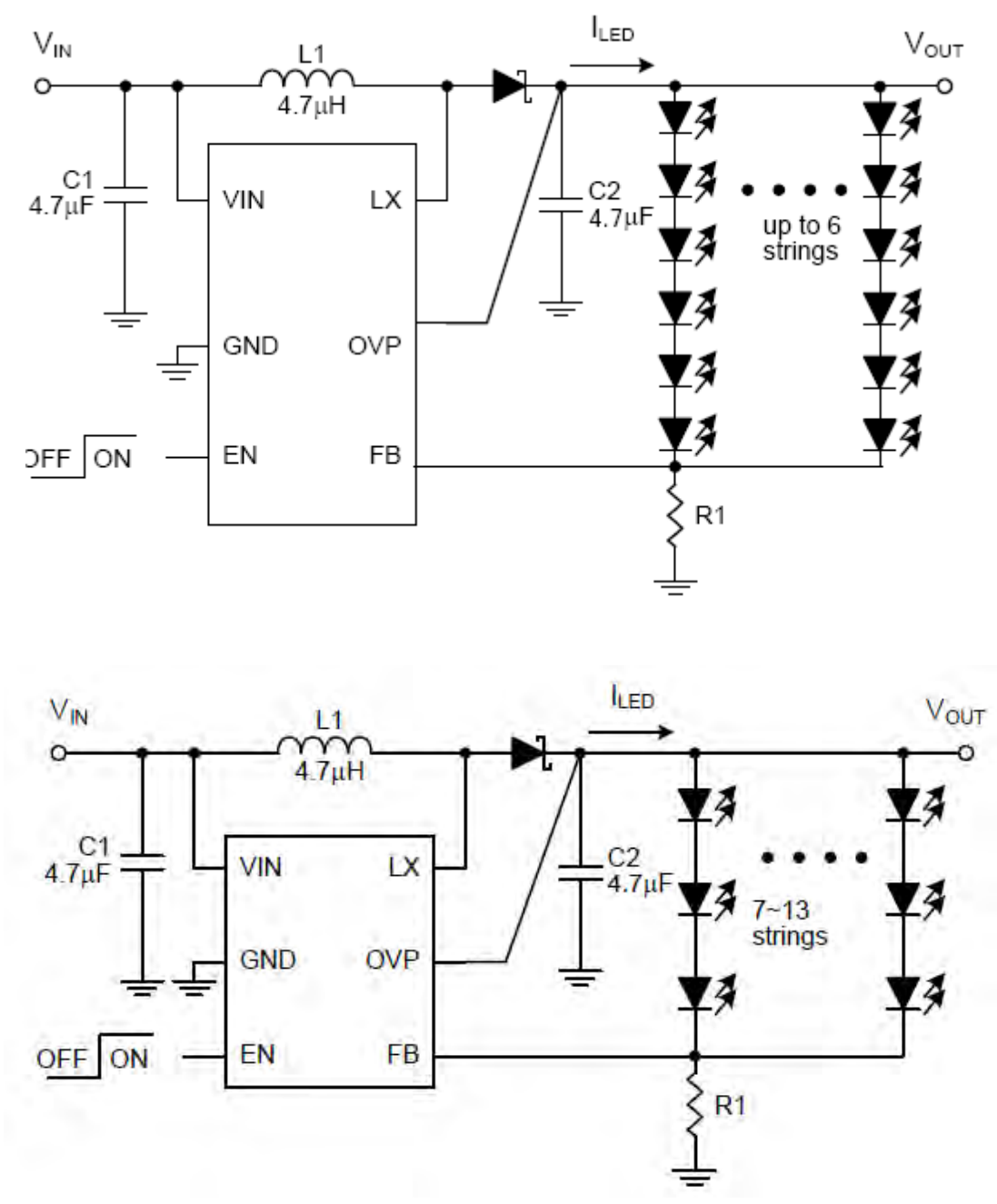



White LED Step-up Converter

Function Description

Main Control Loop

The FTD8203 is a constant frequency current-mode switching regulator. During normal operation, the internal N-channel power MOSFET is turned on each cycle when the oscillator sets an internal RS latch and turned off when an internal comparator (ICMP) resets the latch. The peak inductor current at which ICMP resets the RS latch is controlled by the voltage on the COMP node, which is the output of the error amplifier (EAMP). An external current-sense resistor connected between cathode of the lowest LED and ground allows the EAMP to receive a current feedback voltage V_{FB} at FB pin. When the LEDs voltage decreases to cause the LEDs current to decrease, it causes a slightly decrease in V_{FB} relative to the reference voltage, which in turn causes the COMP voltage to increase until the LEDs current reaches the set point.

VIN Under-Voltage Lockout (UVLO)

The Under-Voltage Lockout (UVLO) circuit compares the input voltage at VIN with the UVLO threshold (2.2V rising, typical) to ensure the input voltage is high enough for reliable operation. The 100mV (typ) hysteresis prevents supply transients from causing a restart. Once the input voltage exceeds the UVLO rising threshold, startup begins. When the input voltage falls below the UVLO falling threshold, the controller turns off the converter.

Soft-Start

The FTD8203 has a built-in soft-start to control the N channel MOSFET current raises during start-up. During soft-start, an internal ramp voltage connected to one of the inverting inputs of the current limit comparator. The inductor current limit is proportional to the voltage. When the threshold voltage of the internal soft-start comparator is reached, the full current limit is released.

Current-Limit Protection

The FTD8203 monitors the inductor current, flowing through the N-channel MOSFET, and limits the current peak at current-limit level to prevent loads and the device from damages in overload conditions.

Over-Temperature Protection (OTP)

The over-temperature circuit limits the junction temperature of the FTD8203. When the junction temperature exceeds 150°C, a thermal sensor turns off the power MOSFET, allowing the device to cool. The thermal sensor allows the converter to start a soft-start process and regulate the LEDs current again after the junction temperature cools by 40°C. The OTP is designed with a 40°C hysteresis to lower the average Junction Temperature (T_J) during continuous thermal overload conditions, increasing the lifetime of the device.

Enable/Shutdown

Driving EN to ground places the FTD8203 in shutdown mode. When in shutdown, the internal power MOSFET turns off, all internal circuitry shuts down and the quiescent supply current reduces to 1uA maximum. This pin also could be used as a digital input allowing brightness controlled by using a PWM signal with frequency from 100Hz to 100kHz. The 0% duty cycle of PWM signal corresponds to zero LEDs current and 100% corresponds to full one. Suggestion dimming duty range is from 8% to 100% at 100kHz dimming frequency.

Open-LED Protection

In driving LED applications, the feedback voltage on FB pin falls down if one of the LEDs, in series, is failed. Meanwhile, the converter unceasingly boosts the output voltage like an open-loop operation. Therefore, an overvoltage protection monitoring the output voltage via OVP pin is integrated into the chip to prevent the LX and the output voltages from exceeding their maximum voltage ratings. Once the voltage on the OVP pin rises above the OVP threshold, the converter stops switching and prevents the output voltage from rising. The converter can work again when the OVP voltage falls below the falling of OVP voltage threshold.

White LED Step-up Converter

Application Information

Input Capacitor Selection

The input capacitor (C_{IN}) reduces the current peaks drawn from the input supply and reduces noise injection into the IC. The reflected ripple voltage will be smaller with larger C_{IN} . For reliable operation, it is recommended to select the capacitor voltage rating at least 1.2 times higher than the maximum input voltage. The capacitors should be placed close to the V_{IN} and GND.

Inductor Selection

For high efficiencies, the inductor should have a low dc resistance to minimize conduction losses. Especially at high-switching frequencies the core material has a higher impact on efficiency. When using small chip inductors, the efficiency is reduced mainly due to higher inductor core losses. This needs to be considered when selecting the appropriate inductor. The inductor value determines the inductor ripple current. The larger the inductor value, the smaller the inductor ripple current and the lower the conduction losses of the converter. Conversely, larger inductor values cause a slower load transient response. A reasonable starting point for setting ripple current, ΔI_L , is 30% to 50% of the average inductor current. The recommended inductor value can be calculated as below:

$$L \geq \left(\frac{V_{IN}}{V_{OUT}} \right)^2 \times \frac{V_{OUT} - V_{IN}}{F_{SW} \times I_{OUT(MAX)}} \times \frac{\eta}{\left(\frac{\Delta I_L}{I_{L(AVG)}} \right)}$$

where

V_{IN} = input voltage

V_{OUT} = output voltage

F_{SW} = switching frequency in MHz

I_{OUT} = maximum output current in amp.

η = Efficiency

$\Delta I_L / I_{L(AVG)}$ = inductor ripple current/average current (0.3 to 0.5 typical)

To avoid saturation of the inductor, the inductor should be rated at least for the maximum input current of the converter plus the inductor ripple current. The maximum input current is calculated as below:

$$I_{IN(MAX)} = \frac{I_{OUT(MAX)} \times V_{OUT}}{V_{IN} \times \eta}$$

The peak inductor current is calculated as the following equation:

$$I_{PEAK} = I_{IN(MAX)} + \frac{1}{2} \cdot \frac{V_{IN} \cdot (V_{OUT} - V_{IN})}{V_{OUT} \cdot L \cdot F_{SW}}$$

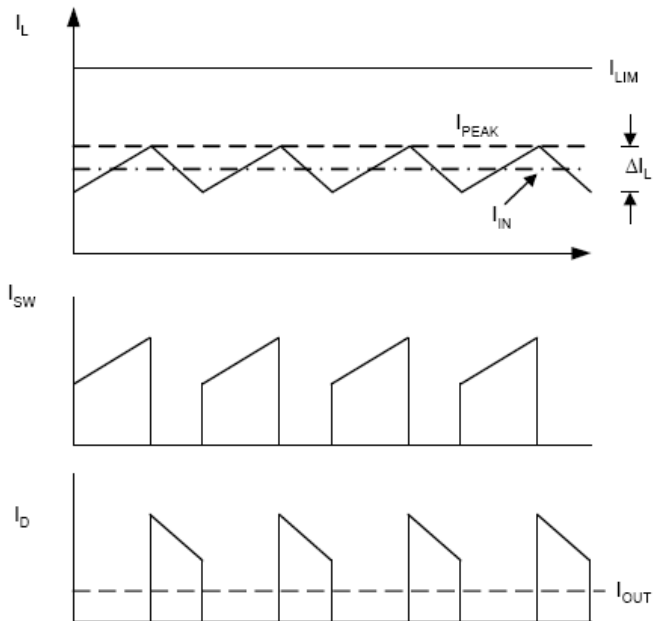
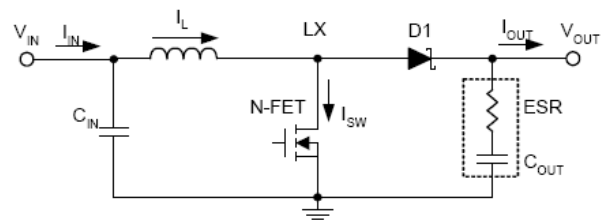

Output Capacitor Selection

The current-mode control scheme of the FTD8203 allows the usage of tiny ceramic capacitors. The higher capacitor value provides good load transient response. Ceramic capacitors with low ESR values have the lowest output voltage ripple and are recommended. If required, tantalum capacitors may be used as well. The output ripple is the sum of the voltages across the ESR and the ideal output capacitor.

$$\Delta V_{OUT} = \Delta V_{ESR} + \Delta V_{COUT}$$

$$\Delta V_{ESR} \approx I_{PEAK} \times R_{ESR}$$

$$\Delta V_{ESR} \approx I_{PEAK} \times R_{ESR}$$

where I_{PEAK} is the peak inductor current.

White LED Step-up Converter

Application Information(Cont.)

Output Capacitor Selection (Cont.)

For ceramic capacitor application, the output voltage ripple is dominated by the ΔV_{COUT} . When choosing the input and output ceramic capacitors, the X5R or X7R with their good temperature and voltage characteristics are recommended.

Setting the LED Current

In figure 1, the converter regulates the voltage on FB pin, connected with the cathode of the lowest LED and the current-sense resistor R1, at 0.2V (typical). Therefore, the current (I_{LED}), flowing via the LEDs and the R1, is calculated by the following equation:

$$I_{\text{LED}} = \frac{0.2V}{R1}$$

Layout Considerations

For all switching power supplies, the layout is an important step in the design; especially at high peak currents and switching frequencies. If the layout is not carefully done, the regulator might show noise problems and duty cycle jitter.

1. The input capacitor should be placed close to the VIN and GND. Connecting the capacitor with VIN and GND pins by short and wide tracks without using any via holes for good filtering and minimizing the voltage ripple.
2. To minimize copper trace connections that can inject noise into the system, the inductor should be placed as close as possible to the LX pin to minimize the noise coupling into other circuits.
3. The feedback network should be routed away from the inductor. The feedback pin and feedback network should be shielded with a ground plane or trace to minimize noise coupling into this circuit.
4. A star ground connection or ground plane minimizes ground shifts and noise is recommended.

White LED Step-up Converter

Package Information

SOT-23-6

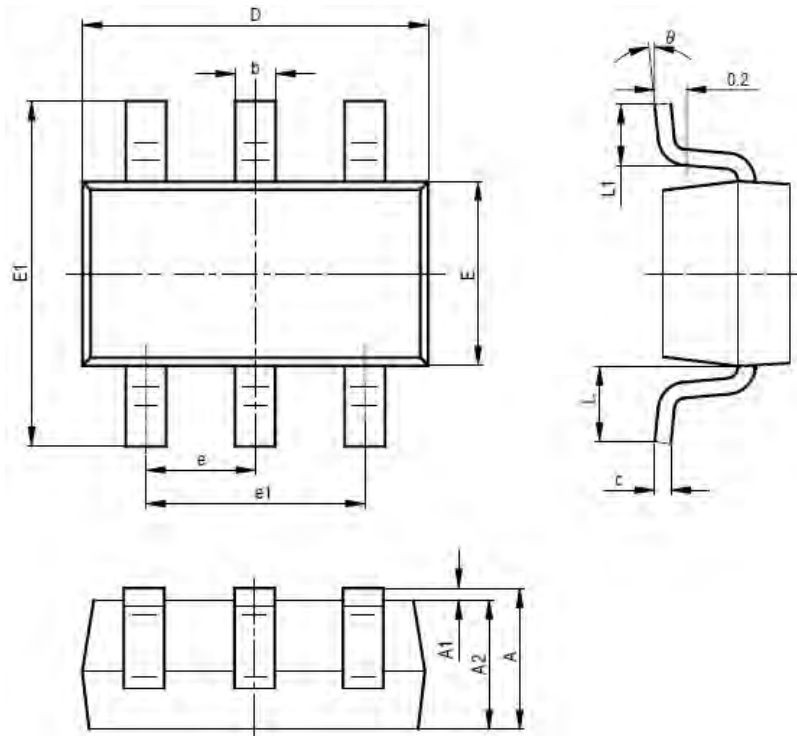

SYMBOL	MILLIMETERS		INCHES	
	MIN	MAX	MIN	MAX
A	1.050	1.250	0.041	0.049
A1	0.000	0.100	0.000	0.004
A2	1.050	1.150	0.041	0.045
b	0.300	0.400	0.012	0.016
c	0.100	0.200	0.004	0.008
D	2.820	3.020	0.111	0.119
E	1.500	1.700	0.059	0.067
E1	2.650	2.950	0.104	0.116
e	0.950TYP		0.037TYP	
e1	1.800	2.000	0.071	0.079
L	0.700REF		0.028REF	
L1	0.300	0.600	0.012	0.024
θ	0°	8°	0°	8°