

Description

The FC3400 is high efficiency synchronous, PWM step-up DC/DC converters optimized to provide a high efficient solution to medium power systems. The devices work with a 1.4MHz fixed frequency switching. These features minimize overall solution footprint by allowing the use of tiny, low profile inductors and ceramic capacitors. Automatic PWM/PFM mode switching at light load saves power and improves efficiency.

The FC3400 is capable of supplying an output voltage between 2.5V and 5V, the internal synchronous switch is desired to provide high efficiency without Schottky.

The FC3400 regulators are available in the industry standard SOT-23-6L power packages (or upon request).

Features

- Up to 94% Efficiency
- Shut-down current: <math><1\mu\text{A}</math>
- Load Current: up to 500mA
- Low Voltage Start-up
- Output Voltage: 2.5V ~ 5V
- Low Switch On Resistance R_{DS} 0.35 Ω
- 1.4MHz Fixed Frequency Switching
- Automatic PWM/PFM Mode Switching
- Low Profile SOT-23-6L Package

Applications

- Digital Cameras and MP3
- Palmtop Computers / PDAs
- Cellular Phones
- Wireless Handsets And DSL Modems
- Portable Media Players

Typical Application Circuit

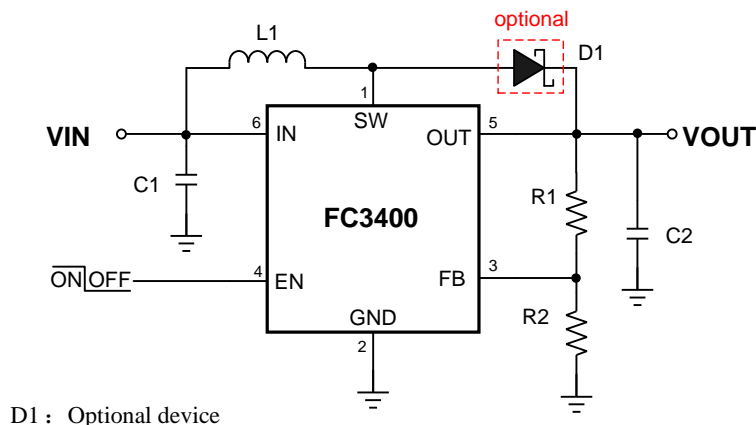
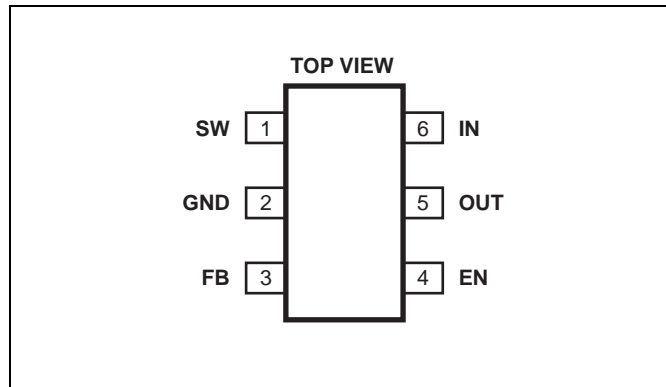

Figure 1: Typical Application Circuit

Pin Assignment and Description



PIN	NAME	DESCRIPTION
1	SW	Switch Output
2	GND	Ground
3	FB	Feedback
4	EN	ON/OFF Control (High Enable)
5	OUT	Output Pin
6	IN	Input

Absolute Maximum Ratings (Note 1)

- > **VIN for FC3400**-0.3V ~ 5V
- > **VOUT** -0.3V ~ 6.6V
- > **VSW** -0.3V ~ 6.6V
- > **VEN** -0.3V ~ 6.6V
- > **Operating Temperature Range (Note 2)**-40°C ~ +85°C
- > **Storage Temperature Range** -65°C ~ +150°C
- > **Junction Temperature**-40°C ~ +125°C
- > **Lead Temperature (Soldering 10 sec.)**+265°C

Note 1: Stresses listed as the above “Absolute Maximum Ratings” may cause permanent damage to the device. Exposure to absolute maximum rating conditions for extended periods may remain possibility to affect device reliability.

Note 2: The FC3400 are guaranteed to meet performance specifications from 0°C to 70°C. Specifications over the - 40°C to 85°C operating temperature range are assured by design, characterization and correlation with statistical process controls.



FC3400

Electrical Characteristics

Operating Conditions: $T_A=25^{\circ}\text{C}$, $V_{IN}=1.2\text{V}$, $V_{OUT}=3.3\text{V}$, unless otherwise specified.

SYMBOL	PARAMETER	CONDITIONS	MIN	TYP	MAX	UNITS
V_{OUT}	Output Voltage Range (Adj.)		2.5		5	V
V_{START}	Minimum Start-up Voltage (Note 3)	$I_{LOAD}=1\text{mA}$		1	1.3	V
V_{MIN}	Minimum Operating	$V_{EN}=V_{IN}$		0.6	0.75	V
I_Q	Quiescent Current	$V_{IN}=1.2\text{V}$	300		500	μA
I_{SHDN}	Shutdown Current	$V_{EN}=0\text{V}$, Including Switch Leakage		0.1	1	μA
V_{FB}	Feedback Voltage		1.165	1.212	1.241	V
I_{FB}	Feedback Input Current	$V_{FB}=1.22\text{V}$		1		nA
f_{OSC}	Switching Frequency		1.1	1.4	1.7	MHz
DC	Max Duty Cycle	$V_{FB}=1.15\text{V}$	80	87		%
V_{ENH}	En Input High		1			V
V_{ENL}	En Input Low				0.5	V
I_{EN}	En Input Current	$V_{EN}=5.5\text{V}$		0.01	1	μA
I_{LIM-N}	NMOS Current Limit		700	850		mA
I_{LK-N}	NMOS Switch Leakage	$V_{SW}=5\text{V}$		0.1	5	μA
I_{LK-P}	PMOS Switch Leakage	$V_{SW}=0\text{V}$		0.1	5	μA
R_{NFET}	NMOS Switch On Resistance	$V_{OUT}=3.3\text{V}$		0.35		Ω
R_{PFET}	PMOS Switch On Resistance	$V_{OUT}=3.3\text{V}$		0.45		Ω

Note 3: Minimum V_{IN} operation after start-up is only limited by the battery's ability to provide the necessary power as it enters a deeply discharged state.



FC3400

Typical Performance Characteristics

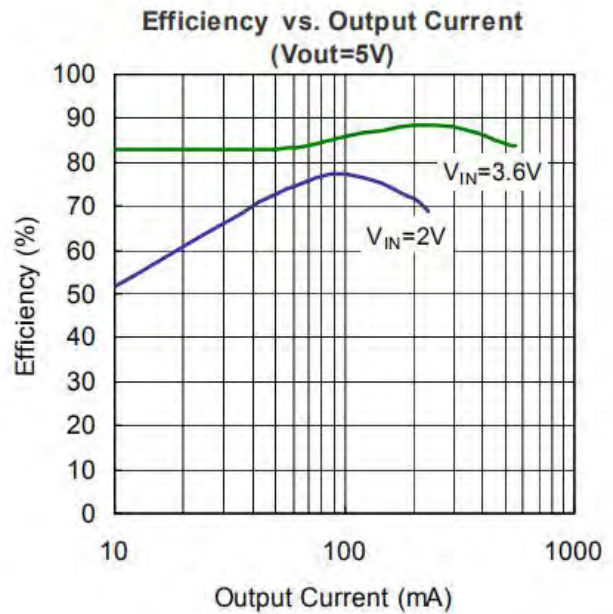
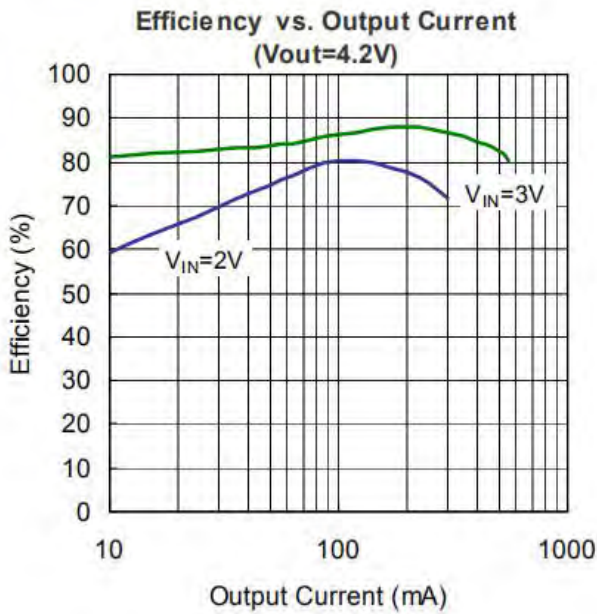
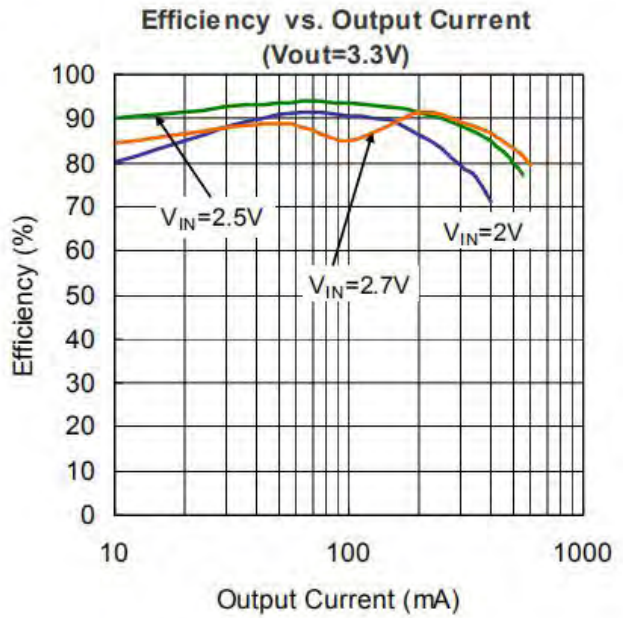
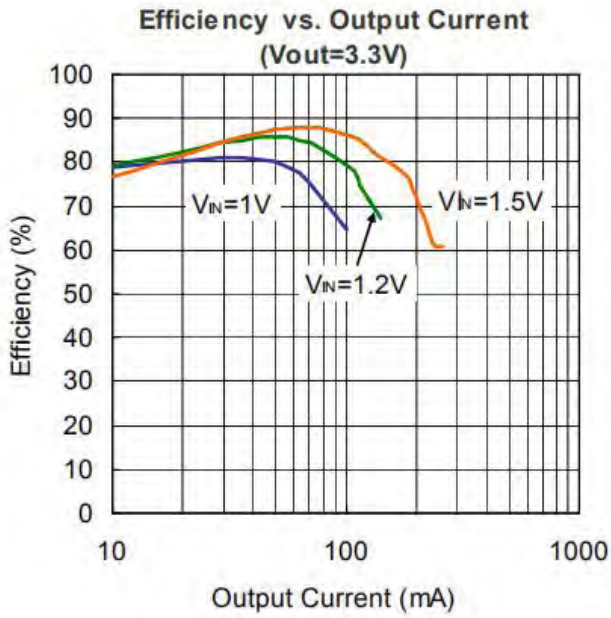



Pin Functions

SW (Pin1): Switch Pin. Connect inductor between SW and VIN. Keep these PCB trace lengths as short and wide as possible to reduce EMI and voltage overshoot.

GND (Pin 2): Signal and Power Ground. Provide a short direct PCB path between GND and the (–) side of the output capacitor(s).

FB (Pin 3): Feedback Input to the g_m Error Amplifier. Connect resistor divider tap to this pin. The output voltage can be adjusted from 2.5V to 5V by: $V_{OUT} = 1.212V \cdot [1 + (R1/R2)]$.

EN (Pin 4): Logic Controlled Shutdown Input. EN = High: Normal free running operation, 1.4MHz typical operating frequency. EN = Low: Shutdown, quiescent current $<1\mu A$. Output capacitor can be completely discharged through the load or feedback resistors.

VOOUT (Pin 5): Output Voltage Pin. PCB trace length from V_{OUT} to the output filter capacitor(s) should be as short and wide as possible.

VIN (Pin 6): Battery Input Voltage. The device gets its start-up bias from V_{IN} . Once V_{OUT} exceeds V_{IN} , bias comes from V_{OUT} . Thus, once started, operation is completely independent from V_{IN} . Operation is only limited by the output power level and the battery's internal series resistance.

Application Information

Inductor Selection

The FC3400 can utilize small surface mount and chip inductors due to their fast 1.4MHz switching frequency. A minimum inductance value of $2.2\mu H$ is necessary for 3.6V and lower voltage applications and $4.7\mu H$ for output voltages greater than 3.6V. Larger values by reducing the inductor ripple current. Increasing the inductance above $10\mu H$ will increase size while providing little improvement in output current capability.

The inductor current ripple is typically set for 20% to 40% of the maximum inductor current (IP). High frequency ferrite core inductor materials reduce frequency dependent power losses compared to cheaper powdered iron types, improving efficiency. The inductor should have low ESR (series resistance of the windings) to reduce the I^2R power losses, and must be able to handle the peak inductor current without saturating. Molded chokes and some chip inductors usually do not have enough core to support the peak inductor currents of 850mA seen on the FC3400. To minimize radiated noise, use a toroid, pot core or shielded bobbin inductor. See Table 1 for some suggested components and suppliers.

Output and Input Capacitor Selection

Low ESR (equivalent series resistance) capacitors should be used to minimize the output voltage ripple. Multilayer ceramic capacitors are an excellent choice as they have extremely low ESR and are available in small footprints. A $4.7\mu F$ to $15\mu F$ output capacitor is sufficient for most applications. Larger values up to $22\mu F$ may be used to obtain extremely low output voltage ripple and improve transient response. An additional phase lead capacitor may be required with output capacitors larger than $10\mu F$ to maintain acceptable phase margin. X5R and X7R dielectric materials are preferred for their ability to maintain capacitance over wide voltage and temperature ranges.



FC3400

Low ESR input capacitors reduce input switching noise and reduce the peak current drawn from the battery. It follows that ceramic capacitors are also a good choice for input decoupling and should be located as close as possible to the device. A 10 μ F input capacitor is sufficient for virtually any application. Larger values may be used without limitations.

Vendor	Part	Inductance (uH)	MAM DCR (ma)	Height (mm)
Sumida (847)956-0666 www.sumida.com	CDRH5D18-4R1	4.1	57	2.0
	CDRH5D18-100	10	124	2.0
	CDRH3D16-4R7	4.7	105	1.8
	CDRH3D16-6R8	6.8	170	1.8
	CR43-4R7	4.7	109	3.5
	CR43-100	10	182	3.5
	CMD4D06-4R7MC	4.7	216	0.8
	CMD4D06-3R3MC	3.3	174	0.8
Coilcraft (847)639-6400 www.coilcraft.com	DS1608-472	4.7	60	2.9
	DS1608-103	10	75	2.9
	DS1608C-472	4.7	90	2.9
Toko (408)432-8282 www.takoam.com	D52LC-4R7M	4.7	84	2.0
	D52LC-100M	10	137	2.0
Murata www.murata.com	LQH3C4R7M24	4.7	195	2.2

PCB Layout Guidelines

The high speed operation of the FC3400 demands careful attention to board layout. You will not get advertised performance with careless layout. A large ground pin copper area will help to lower the chip temperature. A multilayer board with a separate ground plane is ideal, but not absolutely necessary.

Recommended component placement: traces carrying high current are direct. Trace area at FB pin is small. Lead length to battery is short.

Packaging Information

SOT-23-6L Surface Mount Package

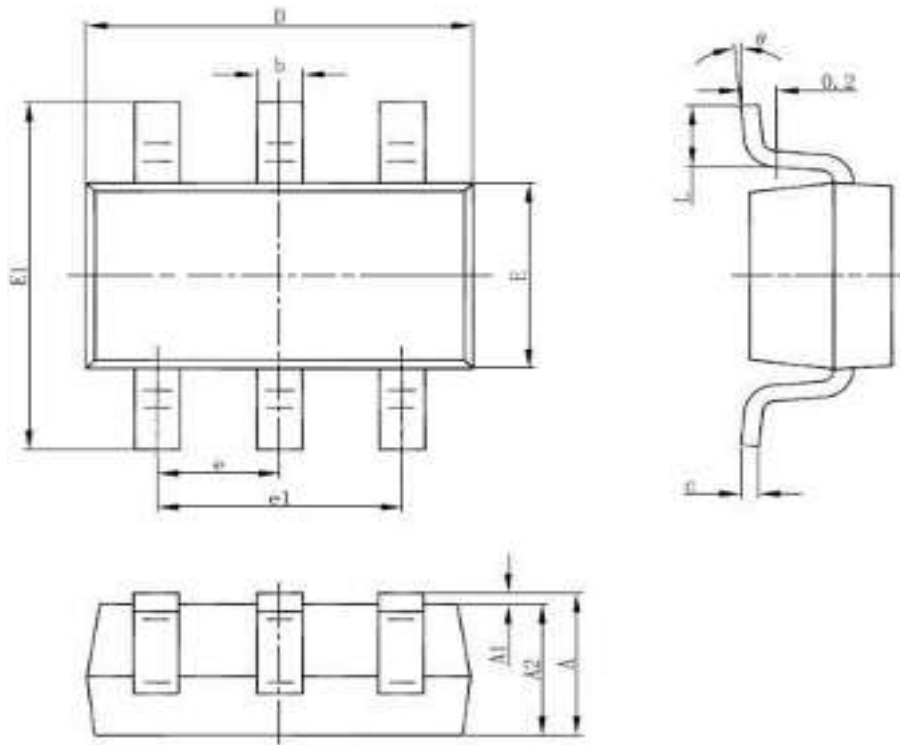

Symbol	Dimensions In Millimeters		Dimensions In Inches	
	Min	Max	Min	Max
A	1.050	1.250	0.041	0.049
A1	0.000	0.100	0.000	0.004
A2	1.050	1.150	0.041	0.045
b	0.300	0.500	0.012	0.020
c	0.100	0.200	0.004	0.008
D	2.820	3.020	0.111	0.119
E	1.500	1.700	0.059	0.067
E1	2.650	2.950	0.104	0.116
e	0.950(BSC)		0.037(BSC)	
e1	1.800	2.000	0.071	0.079
L	0.300	0.600	0.012	0.024
θ	0°	8°	0°	8°