

CMOS IC

SINGLE 2-INPUT EXCLUSIVE-OR GATE

DESCRIPTION

The FC74LVC1G86 is a single 2-input EXCLUSIVE-OR gate which provides the Function $Y = A \oplus B$ or $Y = AB + \bar{A}\bar{B}$ in positive logic. Inputs can be driven from either 3.3V or 5V devices. These features allow the use of these devices in a mixed 3.3V and 5V environment.

This device is fully specified for partial Power-down applications using I_{OFF}. The I_{OFF} circuitry disables the output, preventing the damaging backflow current through the device when it is powered down.

FEATURES

- * Operate from 1.65V to 5.5V
- * Inputs accept voltages to 5.5V
- * I_{OFF} supports partial-power-down mode
- * Low power dissipation
- * Max t_{PD} of 4 ns at 3.3V

ORDERING INFORMATION

Ordering Number		Package	Packing
Lead Free	Halogen Free		
FC74LVC1G86L-AE5-R	FC74LVC1G86G-AE5-R	SOT-23-5	Tape Reel
FC74LVC1G86L-AF5-R	FC74LVC1G86G-AF5-R	SOT-25	Tape Reel
FC74LVC1G86L-AL5-R	FC74LVC1G86G-AL5-R	SOT-353	Tape Reel
FC74LVC1G86L-AN5-R	FC74LVC1G86G-AN5-R	SOT-553	Tape Reel
FC74LVC1G86L-K06-1010X2-R	FC74LVC1G86G-K06-1010X2-R	X2DFN1010-6	Tape Reel

<p>FC74LVC1G86G-AE5-R</p> <p>(1) Packing Type (2) Package Type (3) Green Package</p>	<p>(1) R: Tape Reel (2) AE5: SOT-23-5, AF5: SOT-25, AL5: SOT-353 AN5: SOT-553, K06-1010X2: X2DFN1010-6 (3) G: Halogen Free and Lead Free, L: Lead Free</p>
--	--

MARKING

SOT-23-5 / SOT-25 / SOT-353 / SOT-553	X2DFN1010-6
<p>L: Lead Free G: Halogen Free</p>	

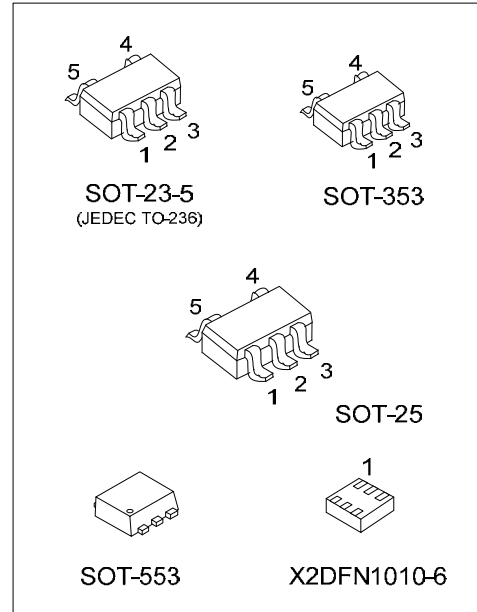

PIN CONFIGURATION

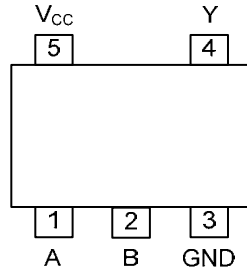

SOT-23-5/SOT-25
SOT-353/SOT-553

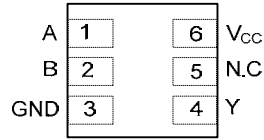

X2DFN1010-6
(TOP VIEW)

FUNCTION TABLE

INPUT(A)	INPUT(B)	OUTPUT(Y)
L	L	L
H	L	H
L	H	H
H	H	L

Note: H: HIGH voltage level; L: LOW voltage level

LOGIC DIAGRAM (positive logic)

For SOT-23-5/SOT-25/SOT-353/SOT-553

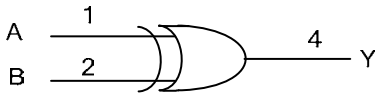

Logic symbol

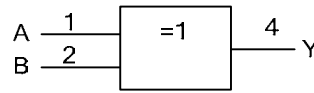

IEC logic symbol

For X2DFN1010-6

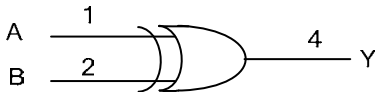

Logic symbol

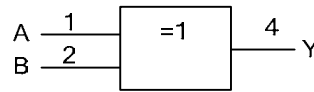

IEC logic symbol



FC74LVC1G86

■ ABSOLUTE MAXIMUM RATING

PARAMETER	SYMBOL	RATINGS	UNIT
Supply Voltage	V_{CC}	-0.5 ~ +6.5	V
Input Voltage	V_{IN}	-0.5 ~ +6.5	V
Output Voltage	V_{OUT}	Output in the high or low state	-0.5 ~ $V_{CC}+0.5$
		Output in the high-impedance or power-off state	-0.5 ~ +6.5
Continuous V_{CC} or GND Current	I_{CC}	±100	mA
Continuous Output Current ($V_{OUT}=0$ to V_{CC})	I_{OUT}	±50	mA
Input Clamp Current ($V_{IN}<0$)	I_{IK}	-50	mA
Output Clamp Current ($V_{OUT}<0$)	I_{OK}	-50	mA
Storage Temperature Range	T_{STG}	-65 ~ +150	°C

Note: Absolute maximum ratings are those values beyond which the device could be permanently damaged. Absolute maximum ratings are stress ratings only and functional device operation is not implied.

■ RECOMMENDED OPERATING CONDITIONS

PARAMETER	SYMBOL	TEST CONDITIONS	MIN	TYP	MAX	UNIT
Supply Voltage	V_{CC}	Operating	1.65		5.5	V
		Data retention only	1.5			V
Input Voltage	V_{IN}		0		5.5	V
Output Voltage	V_{OUT}	High or low state	0		V_{CC}	V
High-level Output Current	I_{OH}	$V_{CC}=1.65V$			-4	mA
		$V_{CC}=2.3V$			-8	mA
		$V_{CC}=3V$			-16	mA
		$V_{CC}=3V$			-24	mA
		$V_{CC}=4.5V$			-32	mA
Low-level Output Current	I_{OL}	$V_{CC}=1.65V$			4	mA
		$V_{CC}=2.3V$			8	mA
		$V_{CC}=3V$			16	mA
		$V_{CC}=3V$			24	mA
		$V_{CC}=4.5V$			32	mA
Input Transition Rise or Fall Rate	$\Delta t/\Delta v$	$V_{CC}=1.8V\pm 0.15V, 2.5V\pm 0.2V$			20	ns/V
		$V_{CC}=3.3V\pm 0.3V$			10	ns/V
		$V_{CC}=5V\pm 0.5V$			5	ns/V
Operating Temperature	T_A		-40		+125	°C



FC74LVC1G86

■ ELECTRICAL CHARACTERISTICS (T_A=25°C , unless otherwise specified)

PARAMETER	SYMBOL	TEST CONDITIONS	MIN	TYP	MAX	UNIT	
High-level Input Voltage	V _{IH}	V _{CC} =1.65V to 1.95V	0.65×V _{CC}			V	
		V _{CC} =2.3V to 2.7V	1.7			V	
		V _{CC} =3V to 3.6V	2			V	
		V _{CC} =4.5V to 5.5V	0.7×V _{CC}			V	
Low-level Input Voltage	V _{IL}	V _{CC} =1.65V to 1.95V			0.35×V _{CC}	V	
		V _{CC} =2.3V to 2.7V			0.7	V	
		V _{CC} =3V to 3.6V			0.8	V	
		V _{CC} =4.5V to 5.5V			0.3×V _{CC}	V	
High-Level Output Voltage	V _{OH}	V _{CC} =1.65 ~ 5.5V, I _{OH} =-100μA	V _{CC} -0.1			V	
		V _{CC} =1.65V, I _{OH} =-4mA	1.2			V	
		V _{CC} =2.3V, I _{OH} =-8mA	1.9			V	
		V _{CC} =3.0V	I _{OH} =-16mA	2.4			V
			I _{OH} =-24mA	2.3			V
V _{CC} =4.5V, I _{OH} =-32mA	3.8			V			
Low-Level Output Voltage	V _{OL}	V _{CC} =1.65 ~ 5.5V, I _{OL} =100μA			0.1	V	
		V _{CC} =1.65V, I _{OL} =4mA			0.45	V	
		V _{CC} =2.3V, I _{OL} =8mA			0.3	V	
		V _{CC} =3.0V	I _{OL} =16mA			0.4	V
			I _{OL} =24mA			0.55	V
V _{CC} =4.5V, I _{OL} =32mA				0.55	V		
Input Leakage Current	I _{I(LEAK)}	V _{CC} =0 ~ 5.5V, V _{IN} =5.5V or GND			±5	μA	
Power OFF Leakage Current	I _{off}	V _{CC} =0V, V _{IN} or V _{OUT} =5.5V			±10	μA	
Quiescent Supply Current	I _{CC}	V _{CC} =1.65 ~ 5.5V, V _{IN} =V _{CC} or GND, I _{OUT} =0			10	μA	
Additional Quiescent Supply Current Per Input Pin	ΔI _{CC}	V _{CC} =3 ~ 5.5V, One input at V _{CC} -0.6V, Other inputs at V _{CC} or GND			500	μA	
Input Capacitance	C _I	V _{CC} =3.3V, V _{IN} =V _{CC} or GND		6		pF	

■ SWITCHING CHARACTERISTICS (T_A=25°C , unless otherwise specified)

PARAMETER	SYMBOL	TEST CONDITIONS	MIN	TYP	MAX	UNIT
Propagation delay from input to output	t _{PLH} t _{PHL}	V _{CC} =1.8±0.15V, C _L =15pF, R _L =1MΩ	2.1		9.1	ns
		V _{CC} =2.5±0.2V, C _L =15pF, R _L =1MΩ	1		4.5	ns
		V _{CC} =3.3±0.3V, C _L =15pF, R _L =1MΩ	0.6		4	ns
		V _{CC} =5±0.5V, C _L =15pF, R _L =1MΩ	0.8		3.3	ns
Propagation delay from input to output	t _{PLH} t _{PHL}	V _{CC} =1.8±0.15V, C _L =30pF, R _L =1KΩ	3.5		9.9	ns
		V _{CC} =2.5±0.2V, C _L =30pF, R _L =500Ω	1.8		5.5	ns
		V _{CC} =3.3±0.3V, C _L =50pF, R _L =500Ω	1.3		5	ns
		V _{CC} =5±0.5V, C _L =50pF, R _L =500Ω	1		4	ns

■ OPERATING CHARACTERISTICS (f=10MHz, T_A=25°C , unless otherwise specified)

PARAMETER	SYMBOL	TEST CONDITIONS	MIN	TYP	MAX	UNIT
Power Dissipation Capacitance	C _{PD}	V _{CC} =1.8V		22		pF
		V _{CC} =2.5V		22		pF
		V _{CC} =3.3V		22		pF
		V _{CC} =5V		24		pF

TEST CIRCUIT AND WAVEFORMS

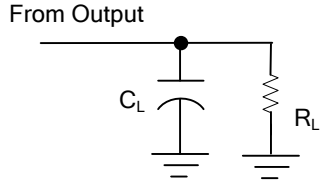

TEST CIRCUIT

V _{CC}	Inputs		V _M	C _L	R _L
	V _{IN}	t _R , t _F			
1.8V±0.15V	V _{CC}	≤2ns	V _{CC} /2	15pF	1MΩ
				30pF	1KΩ
2.5V±0.2V	V _{CC}	≤2ns	V _{CC} /2	15pF	1MΩ
				30pF	500Ω
3.3V±0.3V	3V	≤2.5ns	1.5V	15pF	1MΩ
				50pF	500Ω
5V±0.5V	V _{CC}	≤2.5ns	V _{CC} /2	15pF	1MΩ
				50pF	500Ω

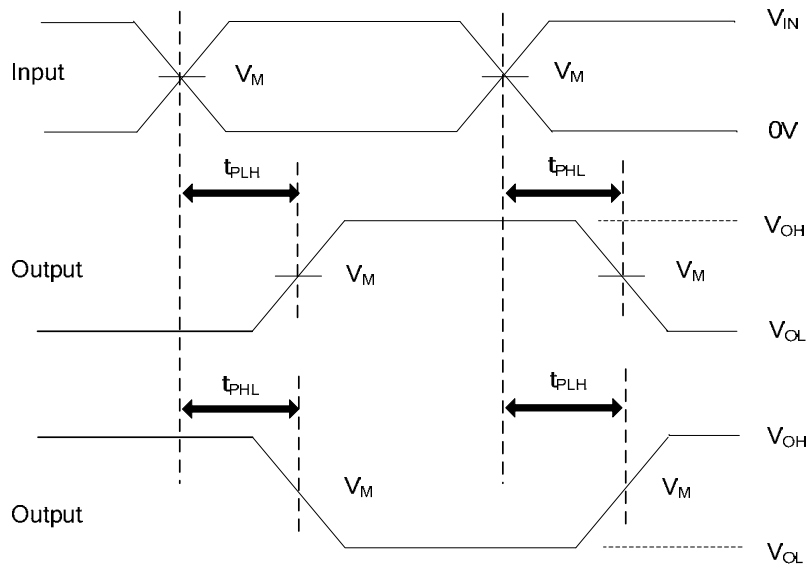

PROPAGATION DELAY TIMES