

CMOS IC

**SINGLE 2-INPUT POSITIVE-OR
GATE**

■ **DESCRIPTION**

The **FC74AHC1G32** is a single 2-input positive-or gate, which provides the function $Y=A+B$ in positive logic.

■ **FEATURES**

- * Operate from 2V to 5.5V
- * Max t_{PD} of 5.5ns at 5 V

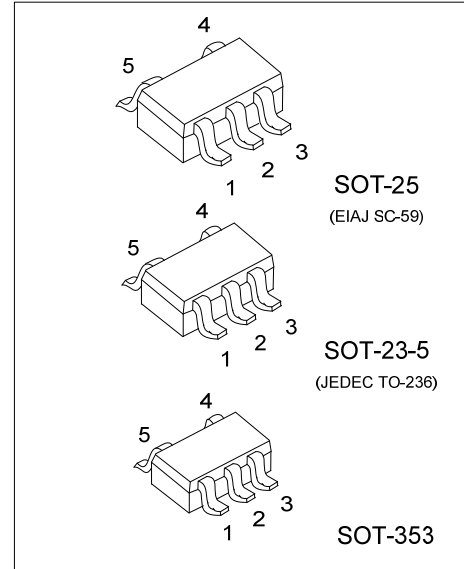

■ **ORDERING INFORMATION**

Ordering Number		Package	Packing
Lead Free	Halogen Free		
FC74AHC1G32L-AE5-R	FC74AHC1G32 G-AE5-R	SOT-23-5	Tape Reel
FC74AHC1G32 L-AF5-R	FC74AHC1G32 G-AF5-R	SOT-25	Tape Reel
FC74AHC1G32 L-AL5-R	FC74AHC1G32 G-AL5-R	SOT-353	Tape Reel

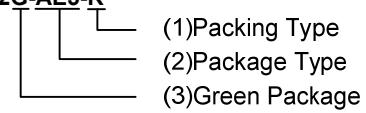
<p>FC74AHC1G32G-AE5-R</p>  <p>(1)Packing Type (2)Package Type (3)Green Package</p>	<p>(1) R: Tape Reel (2) AE5: SOT-23-5, AF5: SOT-25, AL5: SOT-353 (3) G: Halogen Free and Lead Free, L: Lead Free</p>
--	--

■ **MARKING**

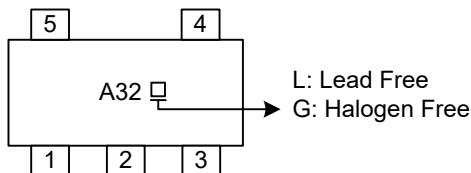

■ PIN CONFIGURATION

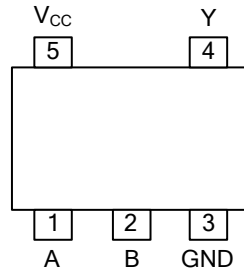

■ FUNCTION TABLE

INPUT(A)	INPUT(B)	OUTPUT(Y)
H	X	H
X	H	H
L	L	L

Note: H: high voltage level; L: low voltage level.

■ LOGIC DIAGRAM

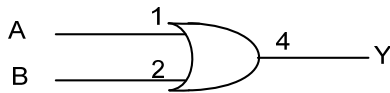



FC74AHC1G32G

■ ABSOLUTE MAXIMUM RATING (T_A=25°C, unless otherwise specified)

PARAMETER	SYMBOL	RATINGS	UNIT	
Supply Voltage	V _{CC}	-0.5 ~ 7	V	
Input Voltage	V _{IN}	-0.5 ~ 7	V	
Output Voltage	V _{OUT}	-0.5 ~ V _{CC} +0.5	V	
V _{CC} or GND Current	I _{CC}	±50	mA	
Output Current	I _{OUT}	±25	mA	
Input Clamp Current	I _{IK}	-20	mA	
Output Clamp Current	I _{OK}	±20	mA	
Power Dissipation	SOT-23-5	P _D	300	mW
	SOT-25		360	mW
	SOT-353		250	mW
Storage Temperature	T _{STG}	-65 ~ +150	°C	

Note: Absolute maximum ratings are those values beyond which the device could be permanently damaged. Absolute maximum ratings are stress ratings only and functional device operation is not implied.

■ RECOMMENDED OPERATING CONDITIONS

PARAMETER	SYMBOL	TEST CONDITIONS	MIN	TYP	MAX	UNIT
Supply Voltage	V _{CC}		2		5.5	V
Input Voltage	V _{IN}		0		5.5	V
Output Voltage	V _{OUT}	High or low state	0		V _{CC}	V
Input Transition Rise or Fall Rate	□t/□V	V _{CC} =3.3V±0.3V			100	ns/V
		V _{CC} =5.0V±0.5V			20	
Operating Temperature	T _A		-40		+125	°C

■ ELECTRICAL CHARACTERISTICS (T_A=25°C, unless otherwise specified)

PARAMETER	SYMBOL	TEST CONDITIONS	MIN	TYP	MAX	UNIT
High-Level Input Voltage	V _{IH}	V _{CC} =2.0V	1.5			V
		V _{CC} =3.0V	2.1			V
		V _{CC} =5.5V	3.85			V
Low-Level Input Voltage	V _{IL}	V _{CC} =2.0V			0.5	V
		V _{CC} =3.0V			0.9	V
		V _{CC} =5.5V			1.65	V
High-Level Output Voltage	V _{OH}	V _{CC} =2.0V, I _{OH} =-50μA	1.9	2.0		V
		V _{CC} =3.0V, I _{OH} =-50μA	2.9	3.0		V
		V _{CC} =4.5V, I _{OH} =-50μA	4.4	4.5		V
		V _{CC} =3.0V, I _{OH} =-4mA	2.58			V
		V _{CC} =4.5V, I _{OH} =-8mA	3.94			V
Low-Level Output Voltage	V _{OL}	V _{CC} =2.0V, I _{OL} =50μA			0.1	V
		V _{CC} =3.0V, I _{OL} =50μA			0.1	V
		V _{CC} =4.5V, I _{OL} =50μA			0.1	V
		V _{CC} =3.0V, I _{OL} =4mA			0.36	V
		V _{CC} =4.5V, I _{OL} =8mA			0.36	V
Input Leakage Current	I _{I(LEAK)}	V _{CC} =0~5.5V, V _{IN} =5.5V or GND			±0.1	μA
Quiescent Supply Current	I _Q	V _{CC} =5.5V, V _{IN} =V _{CC} or GND, I _{OUT} =0A			1	μA
Input Capacitance	C _I	V _{CC} =5.0V, V _{IN} =V _{CC} or GND		2	10	pF



FC74AHC1G32G

■ DYNAMIC CHARACTERISTICS ($T_A=25^\circ\text{C}$, Input: $t_R, t_F \leq 3\text{ns}$; $P_{RR} \leq 1\text{MHz}$)

PARAMETER	SYMBOL	TEST CONDITIONS	MIN	TYP	MAX	UNIT
Propagation Delay Time Input(A or B) to Output(Y)	t_{PLH}	$V_{CC}=3.3\text{V} \pm 0.3\text{V}$, $C_L=15\text{pF}$		5.5	7.9	ns
	t_{PHL}			5.5	7.9	
	t_{PLH}	$V_{CC}=3.3\text{V} \pm 0.3\text{V}$, $C_L=50\text{pF}$		8	12	
	t_{PHL}			8	12	
Propagation Delay Time Input(A or B) to Output(Y)	t_{PLH}	$V_{CC}=5\text{V} \pm 0.5\text{V}$, $C_L=15\text{pF}$		3.8	5.5	ns
	t_{PHL}			3.8	5.5	
	t_{PLH}	$V_{CC}=5\text{V} \pm 0.5\text{V}$, $C_L=50\text{pF}$		5.3	7.5	
	t_{PHL}			5.3	7.5	

■ OPERATING CHARACTERISTICS ($T_A=25^\circ\text{C}$, unless otherwise specified)

PARAMETER	SYMBOL	TEST CONDITIONS	MIN	TYP	MAX	UNIT
Power Dissipation Capacitance	C_{PD}	No load, $V_{CC}=5\text{V}$, $f=1\text{MHz}$		14		pF

■ TEST CIRCUIT AND WAVEFORMS

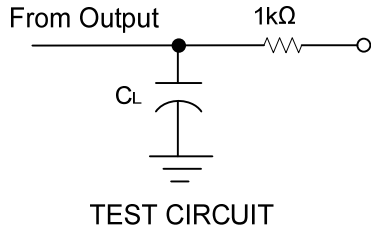

SETUP TIME AND HOLD TIME

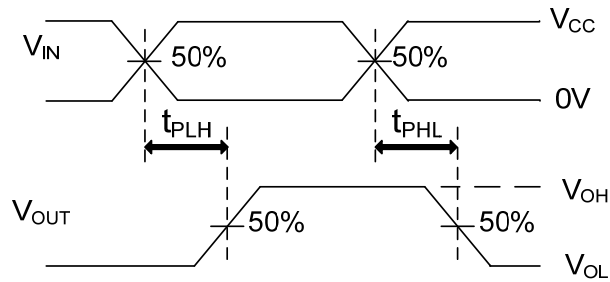

PROPAGATION DELAY TIMES

Note: C_L includes probe and jig capacitance.
 P_{RR} ≅ 1MHz, Z_O=50 Ω , t_R ≅ 3ns, t_F ≅ 3ns