

## LED Driver with Average-Mode Constant Current Control

### Features

- ▶ Fast average current control
- ▶ Programmable constant off-time switching
- ▶ Linear dimming input
- ▶ PWM dimming input
- ▶ Output short circuit protection with skip mode
- ▶ Ambient operating temperature -40°C to +125°C
- ▶ Pin-compatible with the FC9910B

### Applications

- ▶ DC/DC or AC/DC LED driver applications
- ▶ LED backlight driver for LCD displays
- ▶ General purpose constant current source
- ▶ LED signage and displays
- ▶ Architectural and decorative LED lighting
- ▶ LED street lighting

### General Description

The FC9961 is an average current mode control LED driver IC operating in a constant off-time mode. Unlike FC9910B, this control IC does not produce a peak-to-average error, and therefore greatly improves accuracy, line and load regulation of the LED current without any need for loop compensation or high-side current sensing. The output LED current accuracy is  $\pm 3\%$ .

The IC is equipped with a current limit comparator for hiccup-mode output short circuit protection.

The FC9961 can be powered from an 8.0 - 450V supply. A PWM dimming input is provided that accepts an external control TTL compatible signal. The output current can be programmed by an internal 250mV reference, or controlled externally through a 0 - 1.5V dimming input.

FC9961 is pin-to-pin compatible with FC9910B and it can be used as a drop-in replacement for many applications to improve the LED current accuracy and regulation.

### Typical Application Circuit

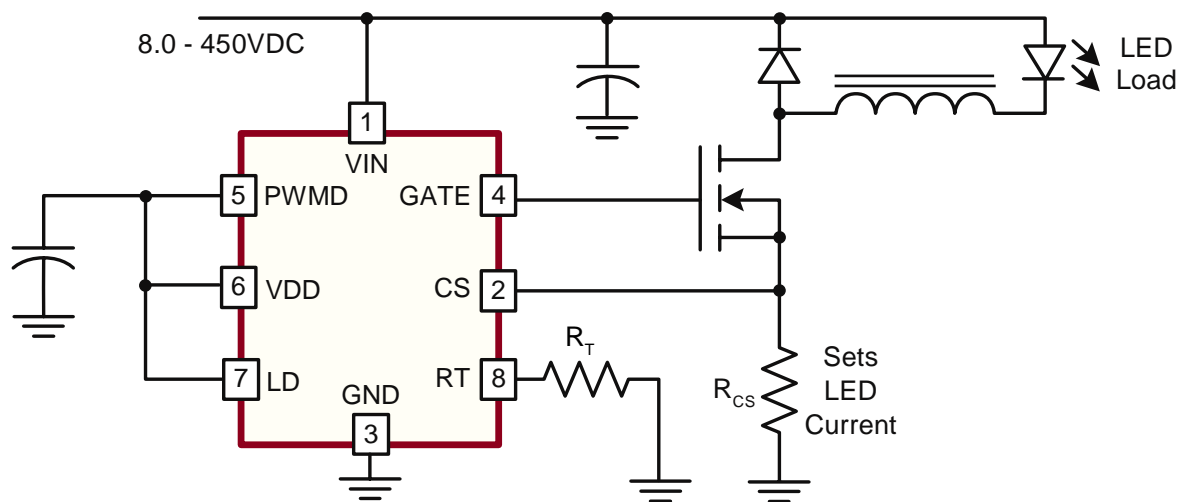

## Absolute Maximum Ratings

Parameter	Value
V <sub>IN</sub> to GND	-0.5V to +470V
V <sub>DD</sub> to GND	12V
CS, LD, PWMD, GATE, RT to GND	-0.3V to (V <sub>DD</sub> +0.3V)
Junction temperature range	-40°C to+150°C
Storage temperature range	-65°C to+150°C
Continuous power dissipation (T <sub>A</sub> = +25°C)	
8-Lead SOIC	650mW
16-Lead SOIC	1000mW

Stresses beyond those listed under "Absolute Maximum Ratings" may cause permanent damage to the device. These are stress ratings only, and functional operation of the device at these or any other conditions beyond those indicated in the operational sections of the specifications is not implied. Exposure to absolute maximum rating conditions for extended periods may affect device reliability.

## Thermal Resistance

Package	θ <sub>JA</sub>
8-Lead SOIC	128 °C/W
16-LeadSOIC	82°C/W

## Pin Configuration

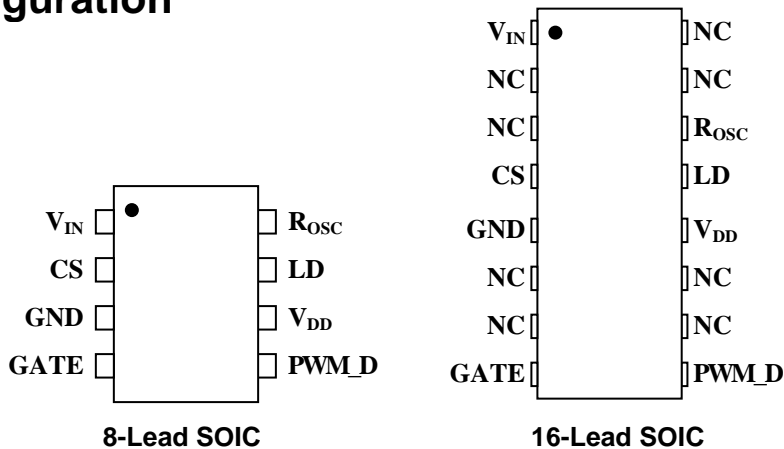



## Electrical Characteristics (Specifications are at $T_A = 25^\circ\text{C}$ . $V_{IN} = 12\text{V}$ , $V_{LD} = V_{DD}$ , $PWMD = V_{DD}$ unless otherwise noted)

Sym	Description	Min	Typ	Max	Units	Conditions
-----	-------------	-----	-----	-----	-------	------------

### Internal Regulator

$V_{DD}$	Internally regulated voltage	-	7.25	7.50	7.75	V	$V_{IN} = 8.0\text{V}$ , $I_{DD(\text{ext})} = 0$ , 500pF at GATE; $R_T = 226\text{k}\Omega$
$\Delta V_{DD, \text{line}}$	Line regulation of $V_{DD}$	-	0	-	1.0	V	$V_{IN} = 8.0 - 450\text{V}$ , $I_{DD(\text{ext})} = 0$ , 500pF at GATE; $R_T = 226\text{k}\Omega$
$\Delta V_{DD, \text{load}}$	Load regulation of $V_{DD}$	-	0	-	100	mV	$I_{DD(\text{ext})} = 0 - 1.0\text{mA}$ , 500pF at GATE; $R_T = 226\text{k}\Omega$
UVLO	$V_{DD}$ undervoltage lockout threshold	*	6.45	6.70	6.95	V	$V_{IN}$ rising
$\Delta\text{UVLO}$	$V_{DD}$ undervoltage lockout hysteresis	-	-	500	-	mV	$V_{IN}$ falling
$I_{IN, \text{MAX}}$	Maximum input current (limited by UVLO)	#	3.5	-	-	mA	$V_{IN} = 8.0\text{V}$ , $T_A = 25^\circ\text{C}$
		#	1.5	-	-		$V_{IN} = 8.0\text{V}$ , $T_A = 125^\circ\text{C}$

### PWM Dimming

$V_{EN(\text{lo})}$	PWMD input low voltage	*	-	-	0.8	V	$V_{IN} = 8.0 - 450\text{V}$
$V_{EN(\text{hi})}$	PWMD input high voltage	*	2.0	-	-	V	$V_{IN} = 8.0 - 450\text{V}$
$R_{EN}$	Internal pull-down resistance at PWMD	-	50	100	150	k $\Omega$	$V_{PWMD} = 5.0\text{V}$

### Average Current Sense Logic

$V_{CS}$	Current sense reference voltage	-	238	250	262	mV	---
$A_{V(\text{LD})}$	LD-to-CS voltage ratio	-	0.176	0.181	0.187	-	---
$\Delta V_{LD(\text{OFFSET})}$	LD-to-CS voltage offset	-	0	-	10	mV	Offset = $V_{CS} - A_{V(\text{LD})} \cdot V_{LD}$ ; $V_{LD} = 1.2\text{V}$
-	CS threshold temp regulation	*	-	-	5.0	mV	---
$V_{LD(\text{OFF})}$	LD input voltage, shutdown	-	-	150	-	mV	$V_{LD}$ falling
$\Delta V_{LD(\text{OFF})}$	LD input voltage, enable	-	-	200	-	mV	$V_{LD}$ rising
$T_{\text{BLANK}}$	Current sense blanking interval	*	150	-	280	ns	---
$T_{\text{ON}(\text{min})}$	Minimum on-time	-	-	-	1000	ns	CS = $V_{CS} + 30\text{mV}$
$D_{\text{MAX}}$	Maximum steady-state duty cycle	-	75	-	-	%	Reduction in output LED current may occur beyond this duty cycle

### Short Circuit Protection

$V_{CS}$	Hiccup threshold voltage	-	410	-	470	mV	---
$T_{\text{DELAY}}$	Current limit delay CS-to-GATE	-	-	-	150	ns	CS = $V_{CS} + 30\text{mV}$
$T_{\text{HICCUP}}$	Short circuit hiccup time	-	350	-	460	$\mu\text{s}$	---
$T_{\text{ON}(\text{min})}$	Minimum on-time (short circuit)	-	-	-	430	ns	CS = $V_{DD}$

#### Notes:

\* Denotes the specifications which apply over the full operating ambient temperature range of  $-40^\circ\text{C} < T_A < +125^\circ\text{C}$ .

# Guaranteed by design.

## Electrical Characteristics (Specifications are at $T_A = 25^\circ\text{C}$ . $V_{IN} = 12\text{V}$ , $V_{LD} = V_{DD}$ , $PWMD = V_{DD}$ unless otherwise noted)

Sym	Description	Min	Typ	Max	Units	Conditions
-----	-------------	-----	-----	-----	-------	------------

### $T_{OFF}$ Timer

$T_{OFF}$	Off time	-	32	40	48	$\mu\text{s}$	$R_T = 1.00\text{M}\Omega$
		-	8.0	10	12		$R_T = 226\text{k}\Omega$

### GATE Driver

$I_{SOURCE}$	GATE sourcing current	-	0.165	-	-	A	$V_{GATE} = 0\text{V}$ , $V_{DD} = 7.5\text{V}$
$I_{SINK}$	GATE sinking current	-	0.165	-	-	A	$V_{GATE} = V_{DD}$ , $V_{DD} = 7.5\text{V}$
$t_{RISE}$	GATE output rise time	-	-	30	50	ns	$C_{GATE} = 500\text{pF}$ , $V_{DD} = 7.5\text{V}$
$t_{FALL}$	GATE output fall time	-	-	30	50	ns	$C_{GATE} = 500\text{pF}$ , $V_{DD} = 7.5\text{V}$

#### Notes:

\* Denotes the specifications which apply over the full operating ambient temperature range of  $-40^\circ\text{C} < T_A < +125^\circ\text{C}$ .

# Guaranteed by design.

## Functional Block Diagram

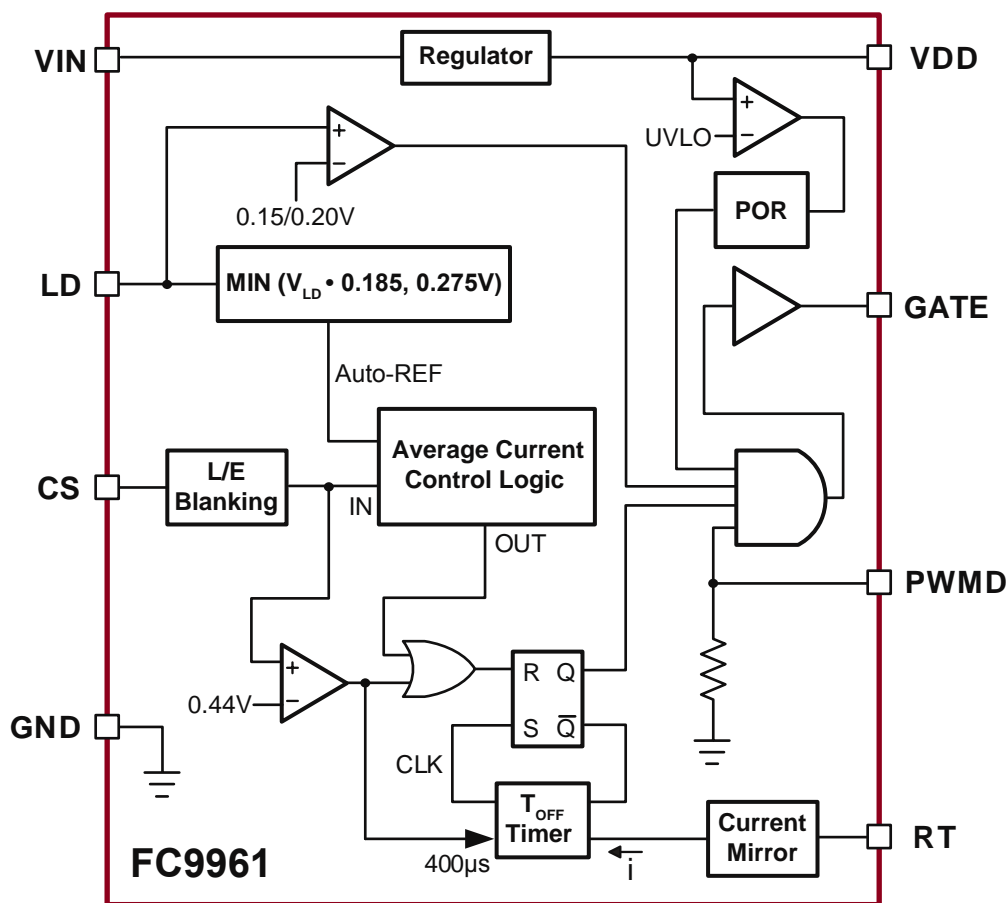

## Application Information

### General Description

Peak-current control (as in FC9910B) of a buck converter is the most economical and simple way to regulate its output current. However, it suffers accuracy and regulation problems that arise from the so-called peak-to-average current error, contributed by the current ripple in the output inductor and the propagation delay in the current sense comparator. The full inductor current signal is unavailable for direct sensing at the ground potential in a buck converter when the control switch is referenced to the same ground potential because the control switch is only conducting for small periods. While it is very simple to detect the peak current in the switch, controlling the average inductor current is usually implemented by level translating the sense signal from  $+V_{IN}$ . Though this is practical for relatively low input voltage  $V_{IN}$ , this type of average-current control may become excessively complex and expensive in the offline AC or other high-voltage DC applications.

The FC9961 employs Supertex' proprietary control scheme, achieving fast and very accurate control of average current in the buck inductor through sensing the switch current only. No compensation of the current control loop is required. The LED current response to PWM input is similar to that of the FC9910B. The inductor current ripple amplitude does not affect this control scheme significantly, and therefore, the LED current is independent of the variation in inductance, switching frequency or output voltage. Constant off-time control of the buck converter is used for stability and to improve the LED current regulation over a wide range of input voltages. (Note that, unlike FC9910B, the FC9961 does not support the constant-frequency mode of operation.)

### OFF Timer

The timing resistor connected to RT determines the off-time of the gate driver, and it must be wired to GND. (Wiring this resistor to GATE as with FC9910B is no longer supported.) The equation governing the off-time of the GATE output is given by:

$$T_{OFF} (\mu s) = \frac{R_T (k\Omega)}{25} + 0.3 \quad (1)$$

within the range of  $30k\Omega \leq R_T \leq 1.0M\Omega$ .

### Average Current Control Feedback and Output Short Circuit Protection

The current through the switching MOSFET source is averaged and used to give constant-current feedback. This current is detected using a sense resistor at the CS pin. The

feedback operates in a fast open-loop mode. No compensation is required. Output current is programmed simply as:

$$I_{LED} = \frac{0.250V}{R_{CS}} \quad (2)$$

when the voltage at the LD input  $V_{LD} \geq 1.5V$ . Otherwise:

$$I_{LED} = \frac{V_{LD} \cdot 0.181}{R_{CS}} \quad (3)$$

The above equations are only valid for continuous conduction of the output inductor. It is a good practice to design the inductor such that the switching ripple current in it is 30–40% of its average peak-to-peak, full load, DC current. Hence, the recommended inductance can be calculated as:

$$L_O = \frac{V_{O(MAX)} \cdot T_{OFF}}{0.4 \cdot I_O} \quad (4)$$

The duty-cycle range of the current control feedback is limited to  $D \leq 0.75$ . A reduction in the LED current may occur when the LED string voltage  $V_O$  is greater than 75% of the input voltage  $V_{IN}$  of the FC9961 LED driver.

Reducing the output LED voltage  $V_O$  below  $V_{O(MIN)} = V_{IN} \cdot D_{MIN}$ , where  $D_{MIN} = 1.0\mu s / (T_{OFF} + 1.0\mu s)$ , may also result in the loss of regulation of the LED current. This condition, however, causes an increase in the LED current and can potentially trip the short-circuit protection comparator.

The typical output characteristic of the FC9961 LED driver is shown in Fig.1. The corresponding FC9910B characteristic is given for the comparison.

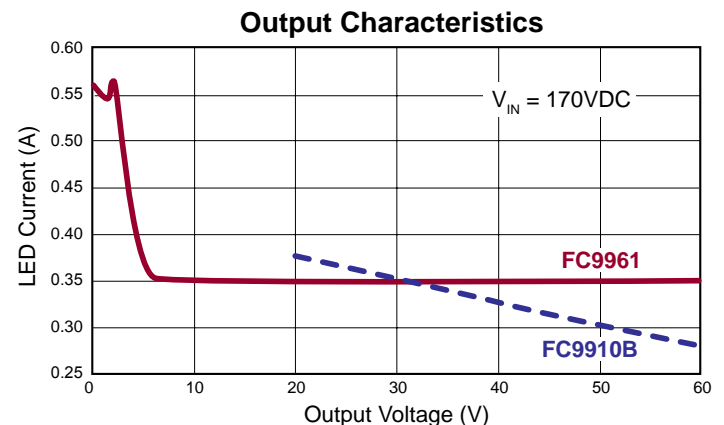

**Fig.1. Typical output characteristic of an FC9961 LED driver.**

The short circuit protection comparator trips when the voltage at CS exceeds  $0.44V$ . When this occurs, the GATE off-time  $T_{HICCUP} = 400\mu s$  is generated to prevent stair-casing of the inductor current and potentially its saturation due to insufficient output voltage. The typical short-circuit current is shown in the waveform of Fig. 2.

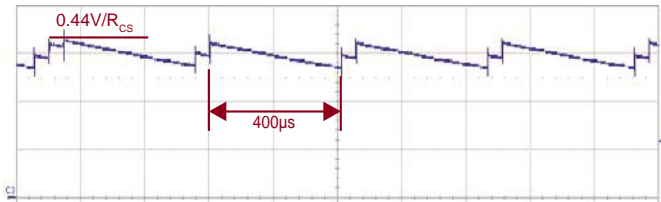
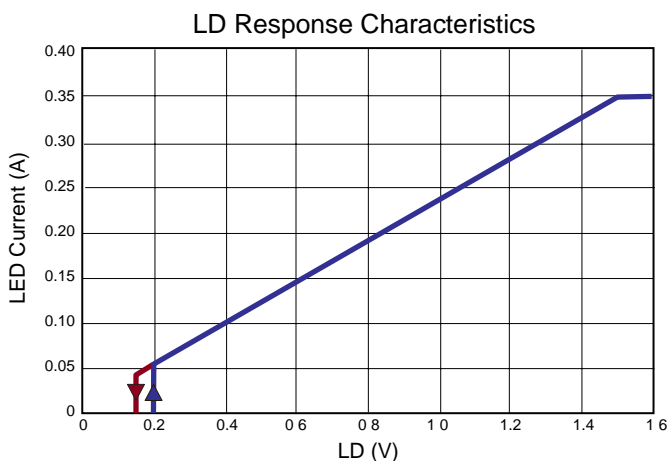

**Fig.2. Short-circuit inductor current.**

A leading-edge blanking delay is provided at CS to prevent false triggering of the current feedback and the short circuit protection.

### Linear Dimming

When the voltage at LD falls below  $1.5V$ , the internal  $275mV$  reference to the constant-current feedback becomes overridden by  $V_{LD} \cdot 0.185$ . As long as the current in the inductor remains continuous, the LED current is given by the equation (3) above. However, when  $V_{LD}$  falls below  $150mV$ , the GATE output becomes disabled. The GATE signal recovers, when  $V_{LD}$  exceeds  $200mV$ . This is required in some applications to be able to shut the LED lamp off with the same signal input that controls the brightness. The typical linear dimming response is shown in Fig.3.



**Fig.3. Typical linear dimming response of an FC9961 LED driver**

The linear dimming input could also be used for “mixed-mode” dimming to expand the dimming ratio. In such case a

pulse-width modulated signal of a measured amplitude below  $1.5V$  should be applied at LD.

### Input Voltage Regulator

The FC9961 can be powered directly from an  $8.0 \sim 450VDC$  supply through its VIN input. When this voltage is applied at the VIN pin, the FC9961 maintains a constant  $7.5V$  level at VDD. This voltage can be used to power the IC and external circuitry connected to VDD within the rated maximum current or within the thermal ratings of the package, whichever limit is lower. The VDD pin must be bypassed by a low ESR capacitor to provide a low impedance path for the high frequency current of the GATE output. The FC9961 can also be powered through the VDD pin directly with a voltage greater than the internally regulated  $7.5V$ , but less than  $12V$ .

Despite the instantaneous voltage rating of  $450V$ , continuous voltage at VIN is limited by the power dissipation in the package. For example, when FC9961 draws  $I_{IN} = 2.0mA$  from the VIN input, and the 8-pin SOIC package is used, the maximum continuous voltage at VIN is limited to:

$$V_{IN(MAX)} = \frac{(T_{J(MAX)} - T_A)}{R_{\theta,JA} \cdot I_{IN}} = 390V \quad (5)$$

where the ambient temperature  $T_A = 25^\circ C$ , the maximum working junction temperature  $T_{J(MAX)} = 125^\circ C$ , the junction-to-ambient thermal resistance  $R_{\theta,JA} = 128^\circ C/W$ .

In such cases, when it is needed to operate the HV9961 from a higher voltage, a resistor or a Zener diode can be added in series with the VIN input to divert some of the power loss from the FC9961. In the above example, using a  $100V$  Zener diode will allow the circuit to work up to  $490V$ . The input current drawn from the VIN pin is represented by the following equation:

$$I_{IN} \approx 1.0mA + Q_G \cdot f_S \quad (6)$$

In the above equation,  $f_S$  is the switching frequency, and  $Q_G$  is the GATE charge of the external FET obtained from the manufacturer’s datasheet.

### GATE Output

The GATE output of the FC9961 is used to drive an external MOSFET. It is recommended that the gate charge  $Q_G$  of the external MOSFET be less than  $25nC$  for switching frequencies  $\leq 100kHz$  and less than  $15nC$  for switching frequencies  $> 100kHz$ .

## PWM Dimming

Due to the fast open-loop response of the average-current control loop of the FC9961, its PWM dimming performance nearly matches that of the FC9910B. The inductor current waveform comparison is shown in Fig. 4.

The rising and falling edges are limited by the current slew rate in the inductor. The first switching cycle is terminated upon reaching the  $250\text{mV} (V_{LD} \cdot 0.181)$  level at CS. The circuit is further reaching its steady-state within 3~4 switching cycles regardless of the switching frequency.

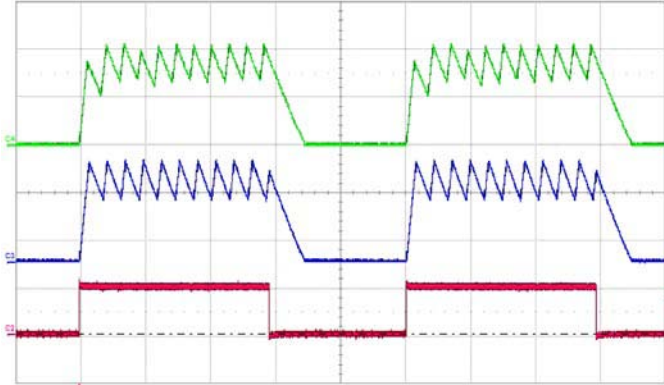

**Fig.4. Typical PWM dimming response of an FC9961 LED driver.**

[CH2 (red): PWMD; CH4 (green): Inductor Current; CH3 (blue):  
Same as FC9910B for comparison]

## Pin Description

Pin #		Function	Description
8-Lead SOIC	16-Lead SOIC		
1	1	VIN	This pin is the input of an 8.0 - 450V linear regulator.
2	4	CS	This pin is the current sense pin used to sense the FET current by means of an external sense resistor.
3	5	GND	Ground return for all internal circuitry. This pin must be electrically connected to the ground of the power train.
4	8	GATE	This pin is the output GATE driver for an external N-channel power MOSFET.
5	9	PWMD	This is the PWM dimming input of the IC. When this pin is pulled to GND, the gate driver is turned off. When the pin is pulled high, the gate driver operates normally.
6	12	VDD	This is the power supply pin for all internal circuits. It must be bypassed with a low ESR capacitor to GND (at least $0.1\mu\text{F}$ ).
7	13	LD	This pin is the linear dimming input, and it sets the current sense threshold as long as the voltage at this pin is less than 1.5V. If voltage at LD falls below 150mV, the GATE output is disabled. The GATE signal recovers at 200mV at LD.
8	14	RT	A resistor connected between this pin and GND programs the GATE off-time.
-	2, 3, 6, 7, 10, 11, 15, 16	NC	No connection