

30V/750mA High Dimming Ratio Constant Current LED Driver

GENERAL DESCRIPTION

The FC1361 is a continuous conduction mode inductive step-down converter, designed for driving single or multiple series connected LEDs efficiently from a voltage source higher than the total LEDs chain voltage. With few outside components, FC1361 provides a high price performance ratio solution on the following applications: MR16 LEDs cup lighting, LEDs stage lighting, LEDs automotive lighting, LEDs solar lighting and LEDs Street lighting. The device operates from an input supply between 5V and 30V and the nominal average output current is set by an external resistor. The device provides an externally adjustable output current of up to 750mA for a single LED. Using the patent technology, the constant current of LED can be up to $\pm 3\%$. A dedicated DIM pin accepts either a DC voltage (0.5V~2.5V) dimming or a wide range of pulsed dimming. Applying a voltage of 0.3V or lower to the DIM pin turns the output off and switches the device into a low current standby state.

FC1361 has a build-in power switch, based on different input voltage, FC1361 can drive several 1W or 3W LEDs. The device has the function of thermal shutdown protection and LED short/open-circuit protection.

The FC1361 is available in SOT89-5 packages.

APPLICATIONS

- Low voltage halogen replacement MR16/11 LEDs
- Automotive LED lighting
- LED stage lighting
- Solar LED lighting
- LED signal lighting
- LED Street lighting

FEATURES

- Simple low parts count
- Wide input voltage range: 5V to 30V
- Typical $\pm 3\%$ output current accuracy
- LED open-circuit protection
- LED short-circuit protection
- Up to 750mA output current
- Single pin on/off and brightness control using DC voltage or PWM
- High efficiency (up to 97%)
- Adjustable Constant LED Current

TYPICAL APPLICATION CIRCUIT

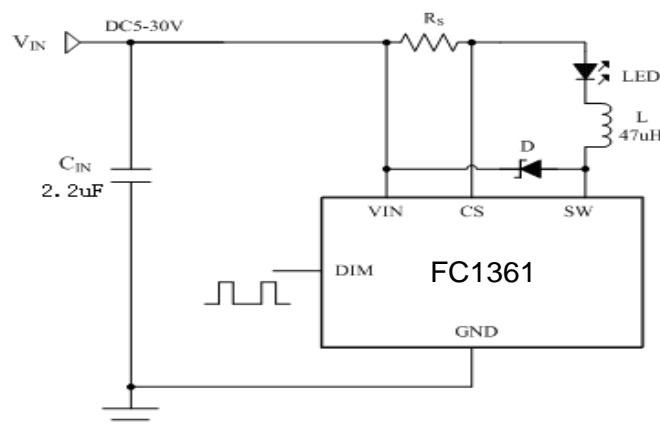
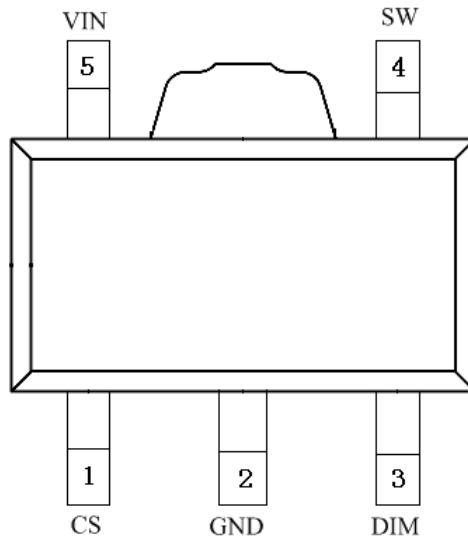

Figure 1. Typical Application Circuit

30V/750mA High Dimming Ratio Constant Current LED Driver

PIN ASSIGNMENT



PIN DESCRIPTIONS

PIN No.	PIN NAMES	DESCRIPTION
1	CS	Current sense input, sampling resistant contacts between CS and VIN
2	GND	Signal and power ground. Connect directly to ground plane.
3	DIM	Enable switch, analog and PWM dimming input.
4	SW	Switch Output. SW is the drain of the internal N-Channel MOSFET switch.
5	VIN	Input Supply Pin. Must be locally bypassed.

ORDERING INFORMATION

PACKAGE	TEMPERATURE RANGE	ORDERING PART NUMBER	TRANSPORT MEDIA	MARKING
SOT89-5	-40 °C to 85 °C	FC1361	Tape and Reel	BP1361



FC1361

30V/750mA High Dimming Ratio Constant Current LED Driver

ABSOLUTE MAXIMUM RATINGS (Note1)

SYMBOL	ITEMS	VALUE	UNIT
V _{IN}	Supply Voltage	-0.3~40	V
SW	Drain Voltage of the internal power switch	-0.3~40	V
CS	Current sense input (Respect to VIN)	+0.3~(-6.0)	V
DIM	Logic level dimming input	-0.3~6	V
I _{SW}	Switch output current	1	A
P _{DMAX}	Power Dissipation (Note 2)	0.6	W
P _{TR}	Thermal Resistance, SOT89-5 θ_{JA}	100	°C /W
T _J	Operation Junction Temperature Range	-40 to 150	°C
T _{STG}	Storage Temperature	-55 to 150	°C
	ESD Susceptibility (Note 3)	2	kV

Note 1: Absolute Maximum Ratings indicate that operating beyond these ratings may damage the device. Recommended Operating Range indicates that the device is functional in that range, but do not guarantee specific performance limits. Electrical Characteristics state DC and AC electrical specifications under particular test conditions which guarantee specific performance limits. This assumes that the device is within the Operating Range. Specifications are not guaranteed for parameters where no limit is given, however, the typical value is a good indication of device performance.

Note 2: The maximum power dissipation must be decreasing with elevating temperatures and is dictated by T_{JMAX}, θ_{JA} , and the ambient temperature T_A. The maximum allowable power dissipation is $P_{DMAX} = (T_{JMAX} - T_A) / \theta_{JA}$ or the lower number given in Absolute Maximum Ratings.

Note 3: Human body model, 100pF discharged through a 1.5k Ω resistor.

RECOMMENDED OPERATING RANGE

SYMBOL	ITEMS	VALUE	UNIT
V _{IN}	V _{DD} Supply Voltage	0 ~ 30	V
T _{OPT}	Operating Temperature	-40 to +85	°C



FC1361

30V/750mA High Dimming Ratio Constant Current LED Driver

ELECTRICAL CHARACTERISTICS (Note 4, 5)

Unless specified otherwise, the following specifications apply for $V_{IN}=12V$, $T_A=25^\circ C$.

SYMBOL	ITEMS	CONDITIONS	Min.	Typ.	Max.	UNIT
V_{IN}	Input Voltage		5		30	V
V_{UVLO}	Under voltage lock out	V_{IN} falling		4.7		V
$V_{UVLO,HYS}$	UVLO hysteresis	V_{IN} rising		100		mV
Current Sense						
V_{CS}	Mean current sense threshold voltage	$V_{IN}-V_{CS}$	97	100	103	mV
$V_{CS,HYS}$	Sense threshold hysteresis			± 15		%
I_{CS}	CS Pin Input Current	$V_{IN}-V_{CS}=50mV$		8		μA
Operating Frequency						
F_{SW}	Maximum operation frequency				1	MHz
Turn Off Current						
I_{OFF}	Quiescent supply current with output off	$V_{DIM}<0.3V$		100		μA
DIM Input						
V_{DIM}	Internal supply voltage	DIM floating		5		V
$V_{DIM,H}$	DIM input voltage High		2.5			V
$V_{DIM,L}$	DIM input voltage Low				0.3	V
R_{DIM}	DIM pull up resistor to internal supply voltage			150		k Ω
$I_{DIM,L}$	DIM input leakage to ground	$V_{DIM} = 0$		33		μA
DIM brightness dimmer						
$V_{DIM,DC}$	DC brightness control		0.5		2.5	V
f_{DIM}	Max. DIM Frequency	$f_{OSC}=500kHz$			50	kHz
$D_{PWM,LF}$	Duty cycle range of low frequency dimming	$f_{DIM}=100Hz$	0.05%		100%	
	Brightness control ratio			2000:1		
$D_{PWM,HF}$	Duty cycle range of high frequency dimming	$f_{DIM}=20KHz$	10%		100%	
	Brightness control ratio			10:1		
Output Power Switch						
R_{SW}	SW On Resistance			0.6		Ω
$I_{SW,mean}$	Continuous SW Current				0.75	A
I_{LEAK}	SW Leakage Current			0.5	5	μA
Thermal Shutdown						
T_{SD}	Thermal Shutdown Threshold			150		$^\circ C$
T_{SD-hys}	Thermal Shutdown hysteresis			20		$^\circ C$

Note 4: Typical parameters are measured at $25^\circ C$ and represent the parametric norm.

Note 5: Datasheet min/max specification limits are guaranteed by design, test, or statistical analysis.



30V/750mA High Dimming Ratio Constant Current LED Driver

OPERATION DESCRIPTION

FC1361 device, in conjunction with the coil (L) and current sense resistor (RS), forms a self oscillating continuous-mode buck converter.

When input voltage VIN is first applied, the initial current in L and RS is zero and there is no output from the current sense circuit. Under this condition, the output of CS comparator is high. This turns on an internal switch and switches the SW pin low, causing current to flow from VIN to ground, via RS, L and the LEDs. The current rises at a rate determined by VIN and L to produce a voltage ramp (VCS) across RS. When $(V_{IN}-V_{CS}) > 115\text{mV}$, the output of CS comparator switches low and the switch turns off. The current flowing on the RS decreases at another rate. When $(V_{IN}-V_{CS}) < 85\text{mV}$, the switch turns on again and the mean current on the LEDs is determined by

$$I_{OUT} = \frac{0.085 + 0.115}{2 \times R_S} = 0.1 / R_S$$

The high-side current-sensing scheme and on-board current-setting circuitry minimize the number of external components while delivering LEDs current with $\pm 3\%$ accuracy, using a 1% sense resistor.

The BP1361 allows dimming with a PWM signal at the DIM input. A logic level below 0.3V at DIM forces FC1361 to turn off the LEDs and the logic level at DIM must be at least 2.5V to turn on the full LEDs current. The frequency of PWM dimming ranges from 100Hz to

more than 20 kHz. When the high voltage is in the range of 0.5V to 2.5V, PWM dimming is available as well. (The detail is in the following application notes.)

The DIM pin can be driven by an external DC voltage (VDIM) to adjust the output current to a value below the nominal average value defined by RS. The DC voltage is valid from 0.5V to 2.5V. When the dc voltage is higher than 2.5V, the output current keeps constant. The LEDs current also can be adjusted by a resistor connected to the DIM pin. An internal pull-up resistor (typical 150kΩ) is connected to a 5V internal regulator. The voltage of DIM pin is divided by the internal and external resistor.

DIM pin can be floated at normal working. When a voltage applied to DIM falls below the threshold (0.3V nom.), the output switch is turned off. The internal regulator and voltage reference remain powered during shutdown to provide the reference for the shutdown circuit. Quiescent supply current during shutdown is nominally 100uA.

Additionally, to ensure the reliability, the FC1361 is built with a thermal shutdown (TSD) protection and can link a NTC closing to LEDs by the pin DIM. As a result, the FC1361S can detect the temperature of LEDs and change the LEDs current to protect LEDs, (The detail is in the following application notes.)

30V/750mA High Dimming Ratio Constant Current LED Driver

APPLICATION NOTES

Setting nominal average output current with external resistor RS

The nominal average output current in the LEDs is determined by the value of the external current sense resistor (RS) connected between VIN and CS and is given by:

$$I_{OUT} = 0.1 / R_S \quad (R_S \geq 0.12\Omega)$$

This equation is valid when DIM pin is floating or applied with a voltage higher than 2.5V (must be less than 5V). Actually, RS sets the maximum average current which can be adjusted to a less one by dimming.

Output current adjustment by external DC control voltage

The DIM pin can be driven by an external dc voltage (VDIM), as shown, to adjust the output current to a value below the nominal average value defined by 0.1/RS.

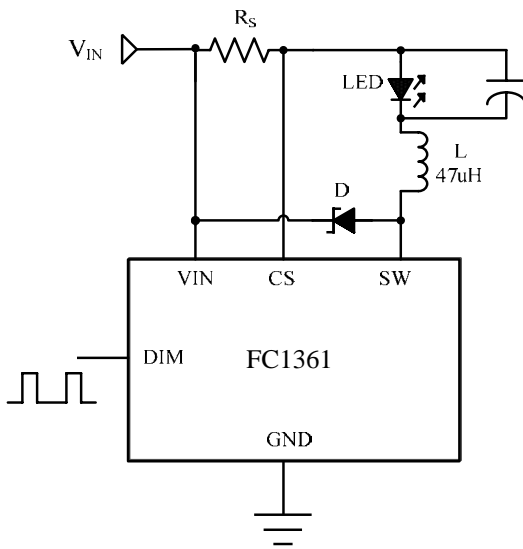

The average output current is given by:

$$I_{OUT} = \frac{0.1 \times (V_{DIM} - 0.5)}{2 \times R_S}$$

$$(0.5V \leq V_{DIM} \leq 2.5V)$$

Note that 100% brightness setting current equaling to $I_{OUT} = 0.1 / R_S$, which corresponds to VDIM:

$$(2.5V \leq V_{DIM} \leq 5V)$$

Output current adjustment by PWM control

A Pulse Width Modulated (PWM) signal with duty cycle PWM can be applied to the DIM pin, as shown below, to adjust the output current to a value below the nominal average value set by resistor RS:

$$I_{OUT} = \frac{0.1 \times D}{R_S}$$

$$(0 \leq D \leq 100\%, 2.5V < V_{pulse} < 5V)$$

If the high voltage is below 2.5V,

$$I_{OUT} = \frac{(V_{pulse} - 0.5) \times 0.1 \times D}{2 \times R_S}$$

$$(0 \leq D \leq 100\%, 0.5V < V_{pulse} < 2.5V)$$

PWM dimming provides reduced brightness by modulating the LEDs forward current between 0% to 100%. The LEDs brightness is controlled by adjusting the relative ratios of the on time to the off time. For example, a 25% pulse width can set LEDs average current to 25% of the nominal value defined by 0.1/RS. To ensure this switching process between on and off state is invisible by human eyes, the switching frequency must be greater than 120 Hz. The advantage of PWM dimming is that the forward current is always constant; therefore the LEDs color does not vary with brightness as it does with analog dimming. Pulsing the current provides precise brightness control while preserving the color purity. The dimming frequency of FC1361 can be as high as 20 kHz.

Shutdown mode

Taking the DIM pin to a voltage below 0.3V will turn off the output and the supply current will fall to a low standby level of 100µA nominal.

Soft-start

An external capacitor from the DIM pin to ground will provide additional soft-start delay on DIM pin, so LED current will increase slowly and soft-start can be done. Normally, the relation of soft-start time and capacitance is approximately 150us/nF.

Inherent open-circuit and short-circuit LED protection

If the connection to the LEDs is open-circuited,



30V/750mA High Dimming Ratio Constant Current LED Driver

FC1361 will operate in safely low power mode. If LEDs is short-circuited, FC1361 will operate in the safe mode with low frequency current limiting protection.

Bypass Capacitor selection

A low ESR capacitor should be used for input decoupling. The larger ESR value will lead to the lower efficient. This capacitor has to support the relatively high peak current to the coil and smooth the current ripple on the input supply. The minimum value of 2.2uF is acceptable in the case of DC input source. For the rectified AC input or low voltage input, the bypass capacitor should be 220uF and the tantalum capacitor is recommended. The input capacitor should be placed as close as possible to the input pin.

For guarantee the stability over temperature and voltage, capacitors with X7R, X5R, or better dielectric are recommended.

Inductor selection

Recommended inductor value for the FC1361 is 47uH. The inductor saturation current must be 30% ~ 50% higher than the output current.

Diode selection

To maximize efficiency and performance, the Diode should be Schottky diode with a fast recovery, low forward voltage, low capacitance and low current leakage. The current and voltage ability depend on the application. Note that diode should have 30% design buffer for stable and reliable operation.

It is very important to consider the reverse leakage of the diode when operating above 85°C. Excess leakage current will increase the power dissipation of system.

The rectifier diode, rectifying AC12V, must use low forward voltage Schottky diode to reduce diode dissipation.

Reducing output ripple

Peak to peak ripple current in the LEDs can be reduced, if required, by shunting a capacitor across the LEDs:

A value of 1uF will reduce the supply ripple current by a factor three approximately. Lower ripple can be achieved with higher capacitor values. Note that the capacitor will not affect operating frequency or efficiency, but it will increase start-up delay and change the frequency of dimming.

Operation Notation at low input voltage

The internal regulator disables the internal power

switch until the input voltage is above the startup threshold ($V_{UVLO}+100mV$). Above the threshold, the device will start to operate. However, there is an especial case that if the input voltage is above the threshold and is too close to the output voltage, then the switch duty cycle will be high and the device power dissipation will enlarge. When device operates in this case for a long time, the device will trigger thermal shutdown (See detail in section of thermal shutdown TSD). In practical application, it's necessary to keep the potential difference between input and output. The drive to the switch is turned off when the input voltage falls below the under-voltage threshold (V_{UVLO}).

Thermal considerations

When the device operates at high ambient temperatures, or drives the maximum load current, care must be taken to avoid exceeding the power limitation. The larger copper area around the chip pin is good to radiate heat. In practical application, the device mounted on a 25mm² PCB must have 1oz copper in current density. Note that the system efficiency will decrease, if utilizing unsuitable coils or excessive parasitic output capacitance on the switch output.

Thermal compensation of output current

High luminance LEDs often need to be supplied with a temperature compensated current in order to maintain stable and reliable operation at all drive levels. FC1361 can use an external temperature sensing network, normally using Negative Temperature Coefficient (NTC) thermal resistors and/or diodes, mounted very close to the LEDs detecting temperature of LEDs and changing LEDs current. The output of the sensing network can be used to drive the DIM pin in order to reduce output current with increasing temperature.

Thermal shutdown protection

To ensure the reliability, the FC1361 is built with a thermal shutdown (TSD) protection function. The TSD protects the IC from over temperature (150°C). When the chip temperature decreases below (130°C), the IC recovers again.

PCB Layout considerations

Careful PCB layout is critical to achieve low switching losses and stable operation. Use a multilayer board whenever possible for better noise immunity. In order to minimize current loop noise, the input bypass capacitor should have an isolate ground plane.



30V/750mA High Dimming Ratio Constant Current LED Driver

SW pin

The SW pin of the device is a fast switching node, so PCB tracks should be kept as short as possible. Moreover, the ground pin of the device should be soldered directly to the ground plane.

Coil and decoupling capacitors and current sense resistor

It is particularly important to mount the coil and the input decoupling capacitor as close to the device pins as possible to minimize parasitic resistance and inductance, if not system efficiency will be degraded. Depending on PCB design, more copper tracks between coil and GND/VCC are useful for lowering interface of coil skein. It is also important to minimize any track resistance in series with current sense resistor RS, to keep the accuracy of sampling current.



FC1361

30V/750mA High Dimming Ratio Constant Current LED Driver

TYPICAL PERFORMANCE CHARACTERISTICS

1) Output Current vs Input Voltage of 1W LED

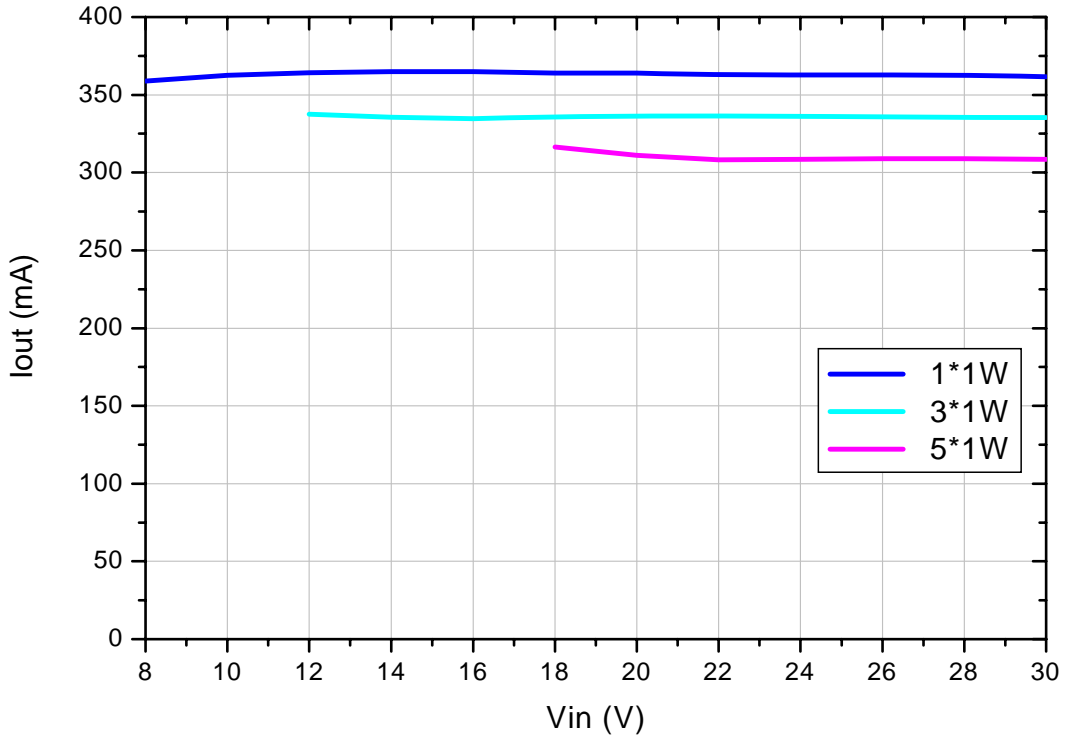

2) Output Current Deviation vs Input Voltage of 1W LED

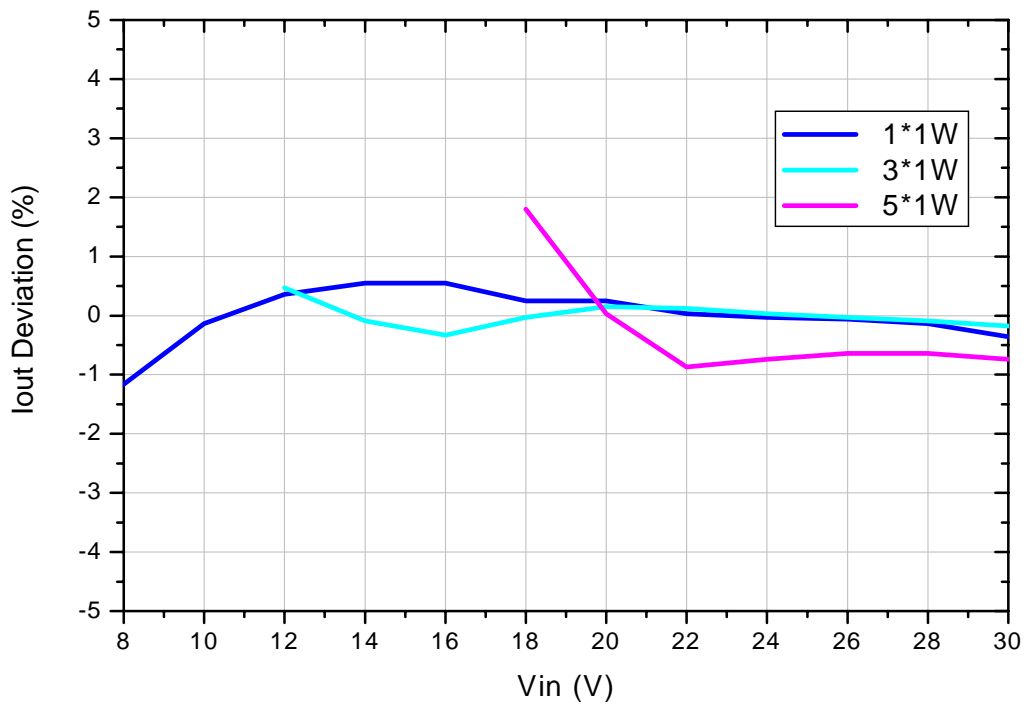



FC1361

30V/750mA High Dimming Ratio Constant Current LED Driver

3) System Efficiency vs Input Voltage of 1W LED

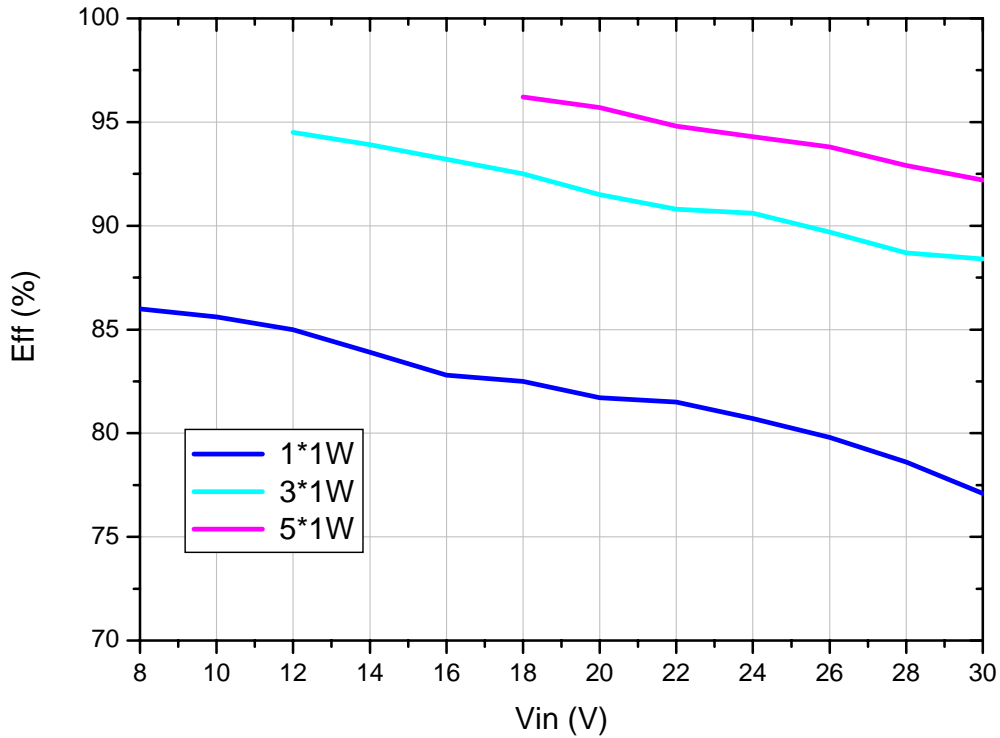

4) Output Current vs Input Voltage of 3W LED

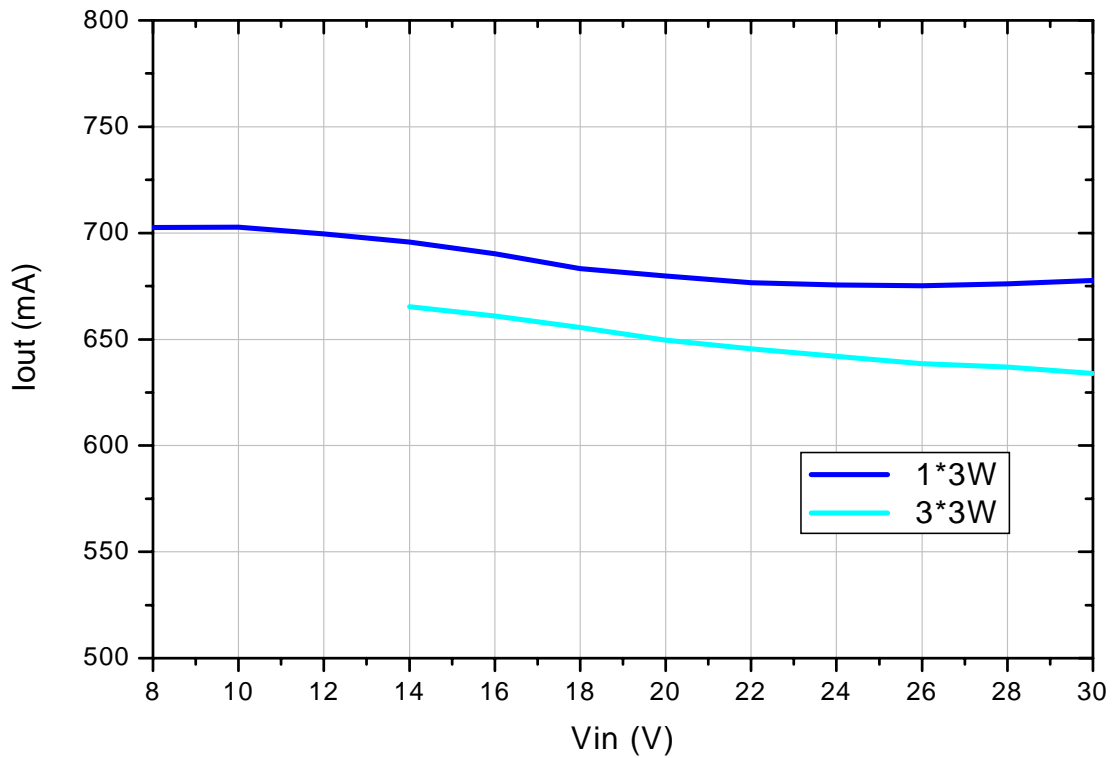



FC1361

30V/750mA High Dimming Ratio Constant Current LED Driver

5) Output Current Deviation vs Input Voltage of 3W LED

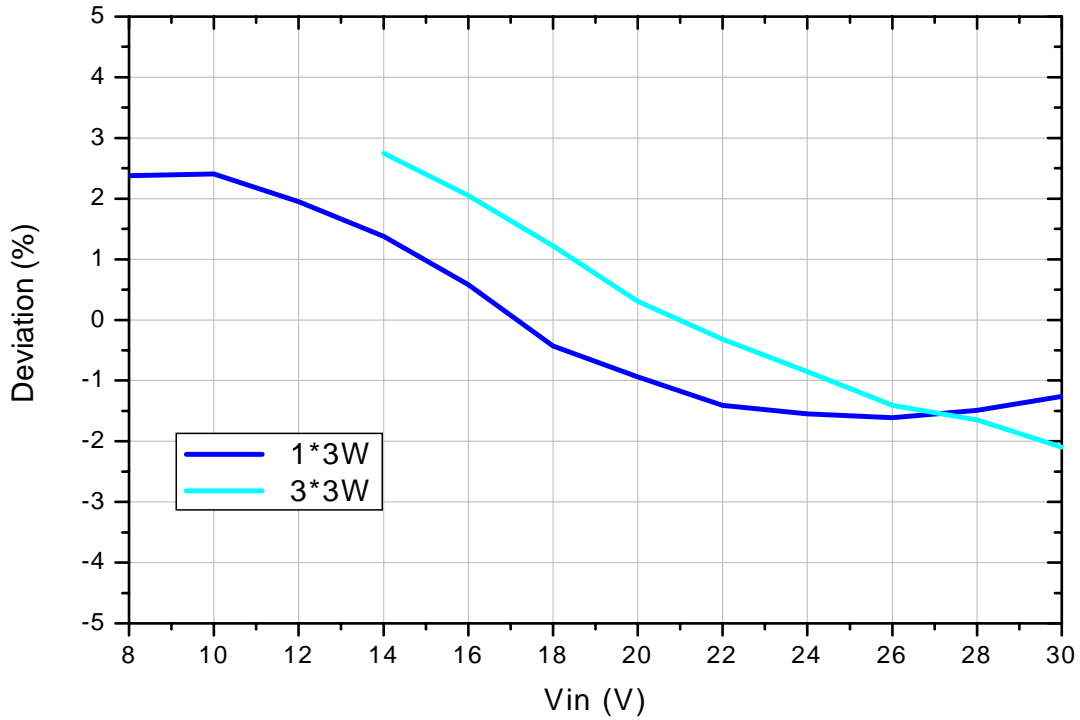

6) System Efficiency vs Input Voltage of 3W LED

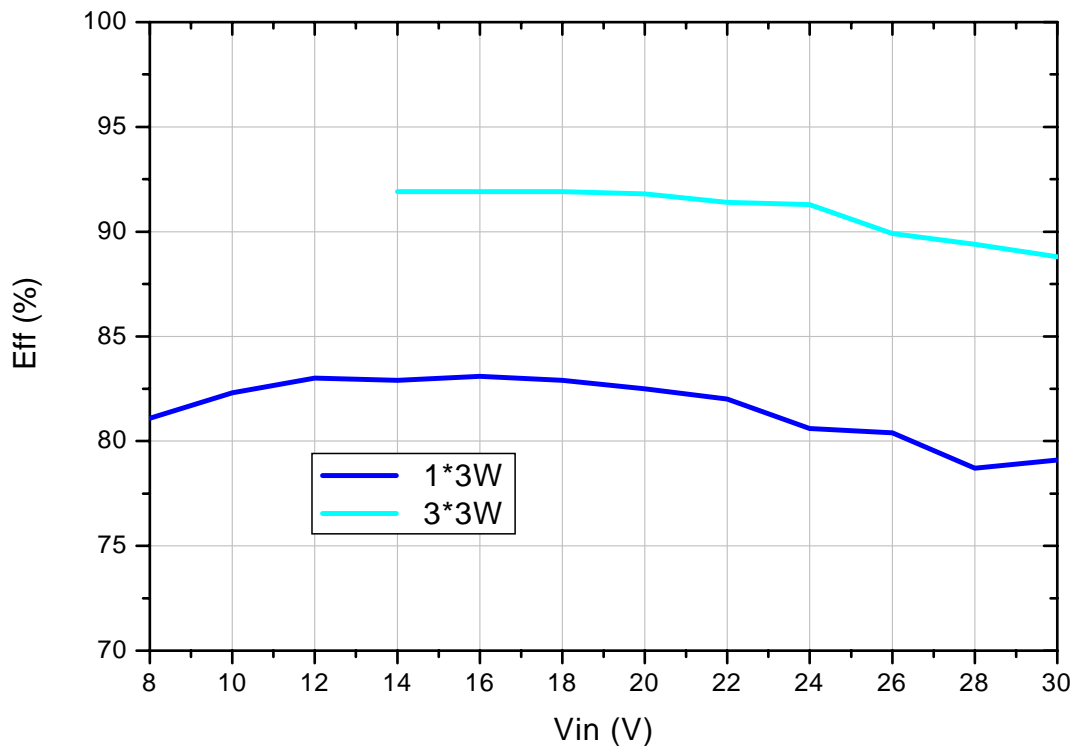



FC1361

30V/750mA High Dimming Ratio Constant Current LED Driver

7) LED Current vs Vdim

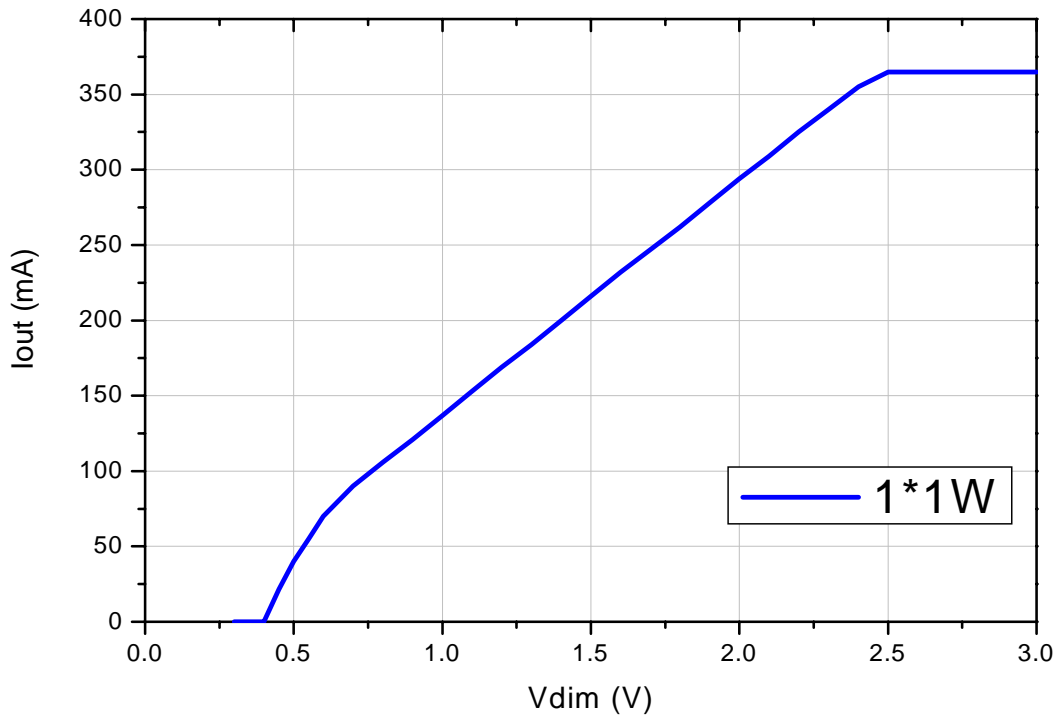

8) Output Current vs Dim Duty (200Hz)

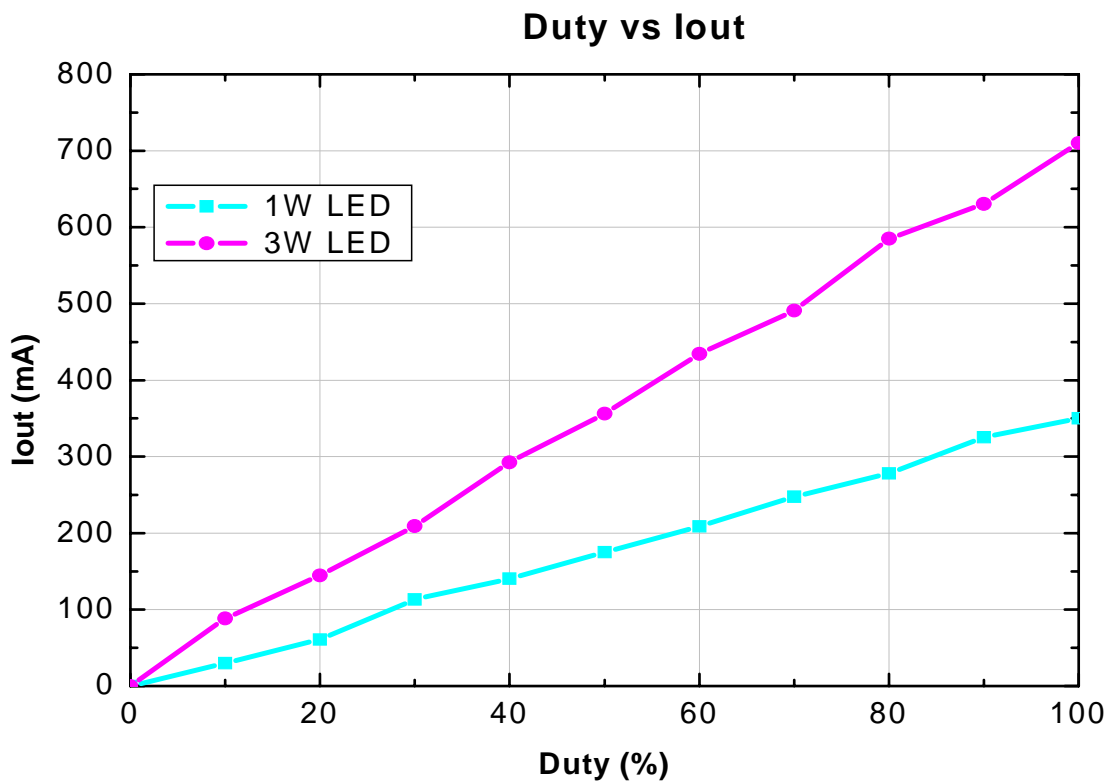

30V/750mA High Dimming Ratio Constant Current LED Driver

9) Vcs vs Temperature

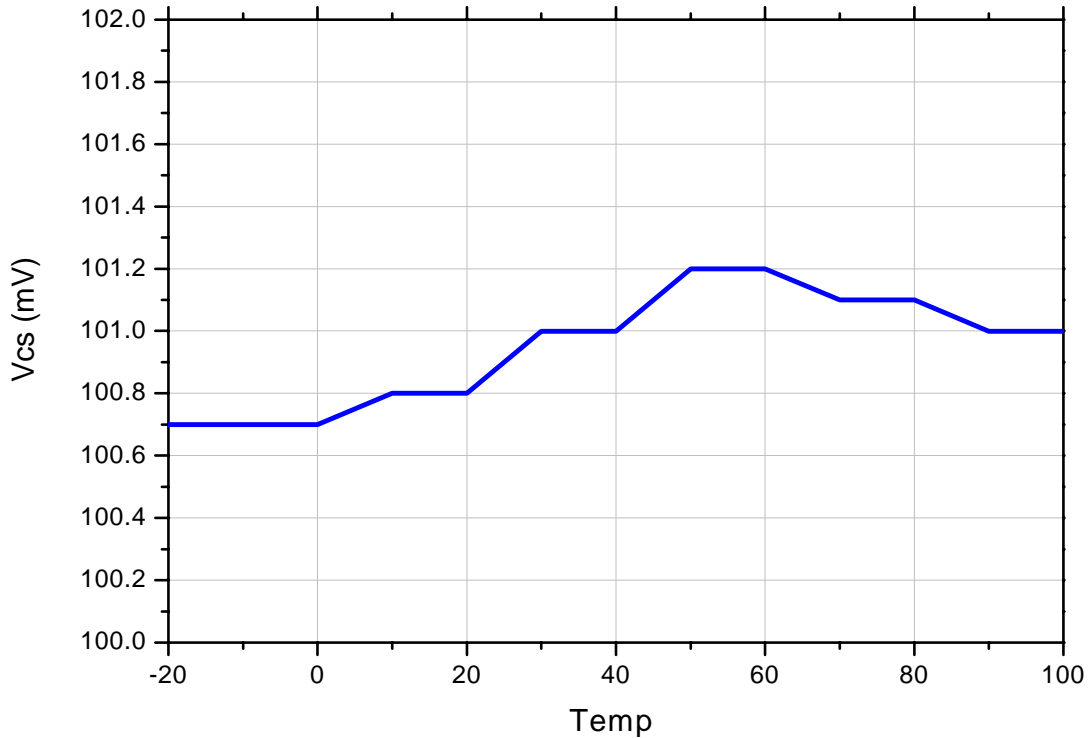

TYPICAL APPLICATION CIRCUIT of MR16

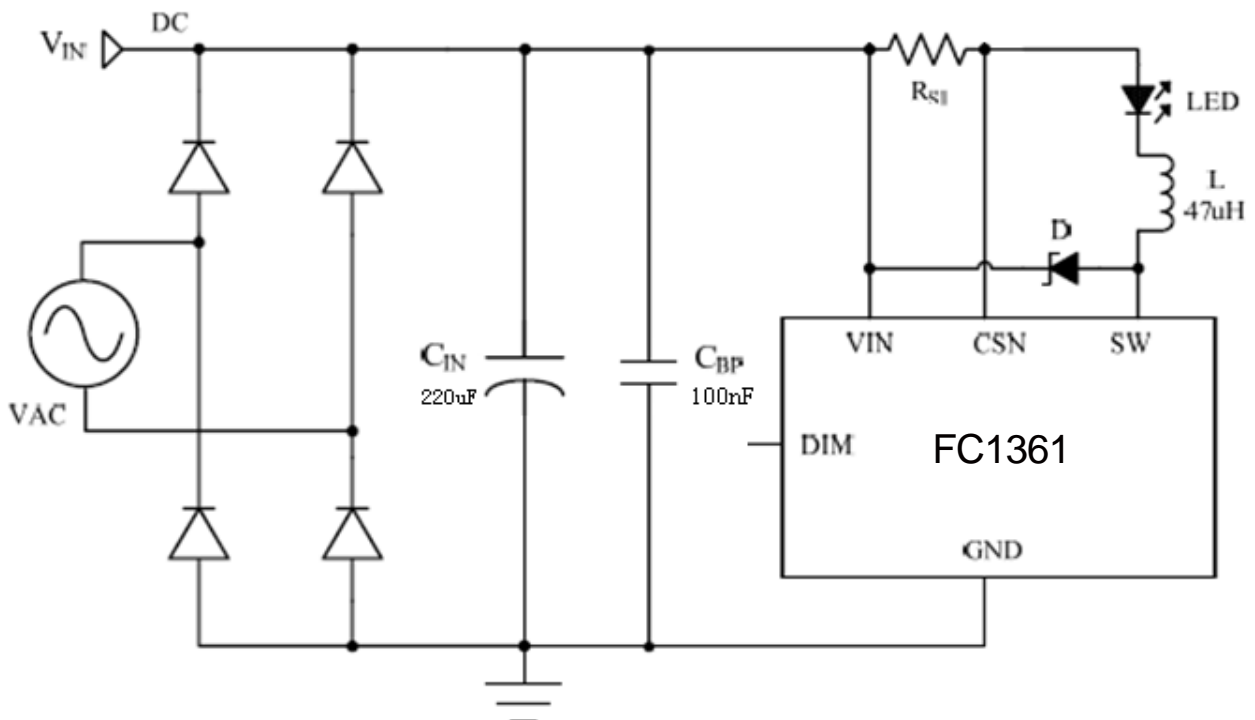

30V/750mA High Dimming Ratio Constant Current LED Driver

PACKAGE INFORMATION

SOT89-5 Package

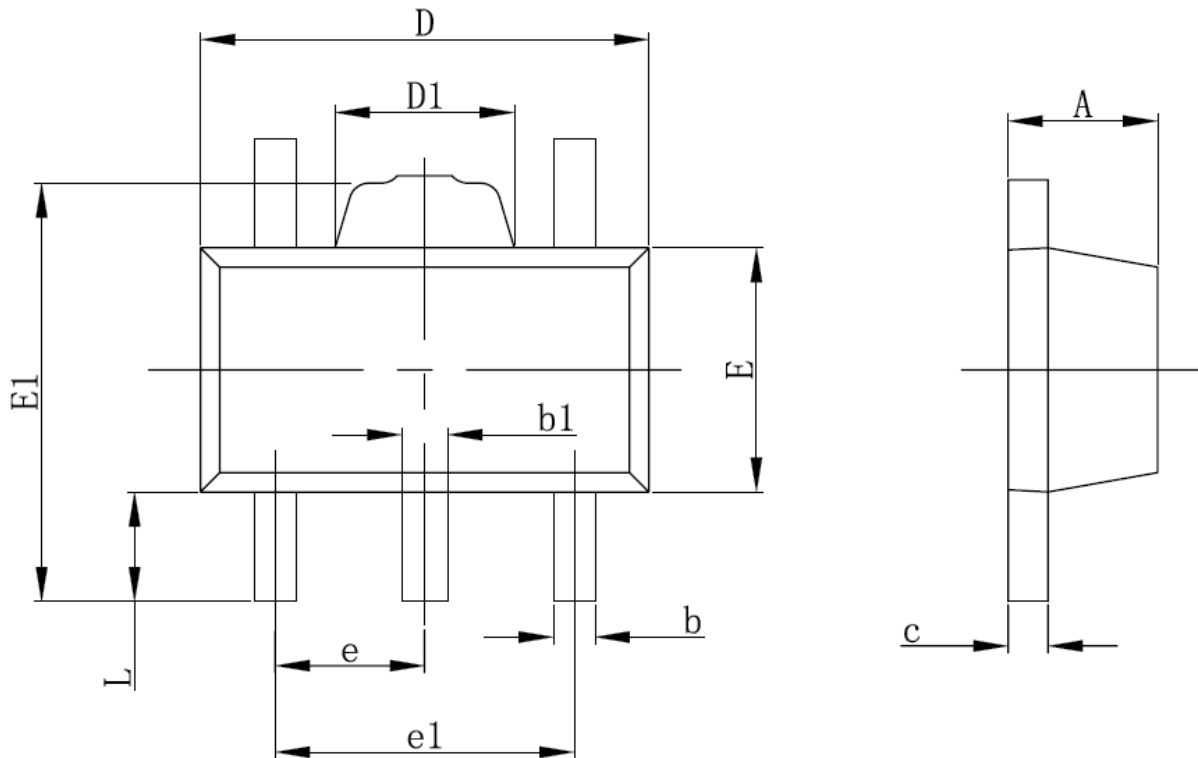

Symbol	Dimensions In Millimeters		Dimensions In Inches	
	Min	Max	Min	Max
A	1.400	1.600	0.055	0.063
b	0.320	0.520	0.013	0.020
b1	0.360	0.560	0.014	0.022
c	0.350	0.440	0.014	0.017
D	4.400	4.600	0.173	0.181
D1	1.400	1.800	0.055	0.071
E	2.300	2.600	0.091	0.102
E1	3.940	4.250	0.155	0.167
e	1.500TYP		0.060TYP	
e1	2.900	3.100	0.114	0.122
L	0.900	1.100	0.035	0.043