

1A Stand alone Linear Li-Ion Battery Charger with Thermal Regulation

General Description

The FC9056 is a complete constant-current/constant-voltage linear charger for single cell lithium-ion batteries. Its SOP package and low external component count make the FC9056 ideally suited for portable applications. Furthermore, the FC9056 can work within USB and wall adapter. No blocking diode is required due to the internal PMOSFET architecture and have prevent to negative Charge Current Circuit. Thermal feedback regulates the charge current to limit the die temperature during high power operation or high ambient temperature. The charge voltage is fixed at 4.2V, and the charge current can be programmed externally with a single resistor. The FC9056 automatically terminates the charge cycle when the charge current drops to 1/10th the programmed value after the final float voltage is reached.

FC9056 Other features include current monitor, under voltage lockout, automatic recharge and two status pin to indicate charge termination and the presence of an input voltage.

Features

- Programmable Charge Current Up to 1000mA
- No MOSFET, Sense Resistor or Blocking Diode Required
- Complete Linear Charger in SOP-8E Package for Single Cell Lithium-Ion Batteries
- Constant-Current/Constant-Voltage
- Charges Single Cell Li-Ion Batteries Directly from USB Port
- Preset 4.2V Charge Voltage with 1.5% Accuracy
- Automatic Recharge
- Charge Status Output Pins
- C/10 Charge Termination
- 2.9V Trickle Charge Threshold
- Soft-Start Limits Inrush Current
- Available Radiator in SOP-8E Package, the Radiator need connect GND or impending

Applications

- Cellular Telephones, PDAs, GPS
- Charging Docks and Cradles
- Digital Still Cameras, Portable Devices
- USB Bus-Powered Chargers, Chargers

Package Types

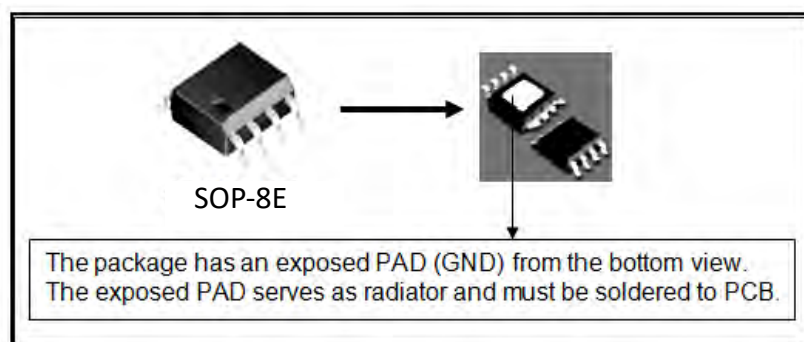

Figure 1. Package Types of FC9056

1A Stand alone Linear Li-Ion Battery Charger with Thermal Regulation

Pin Configurations

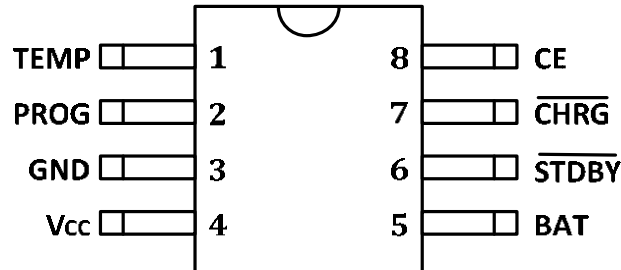
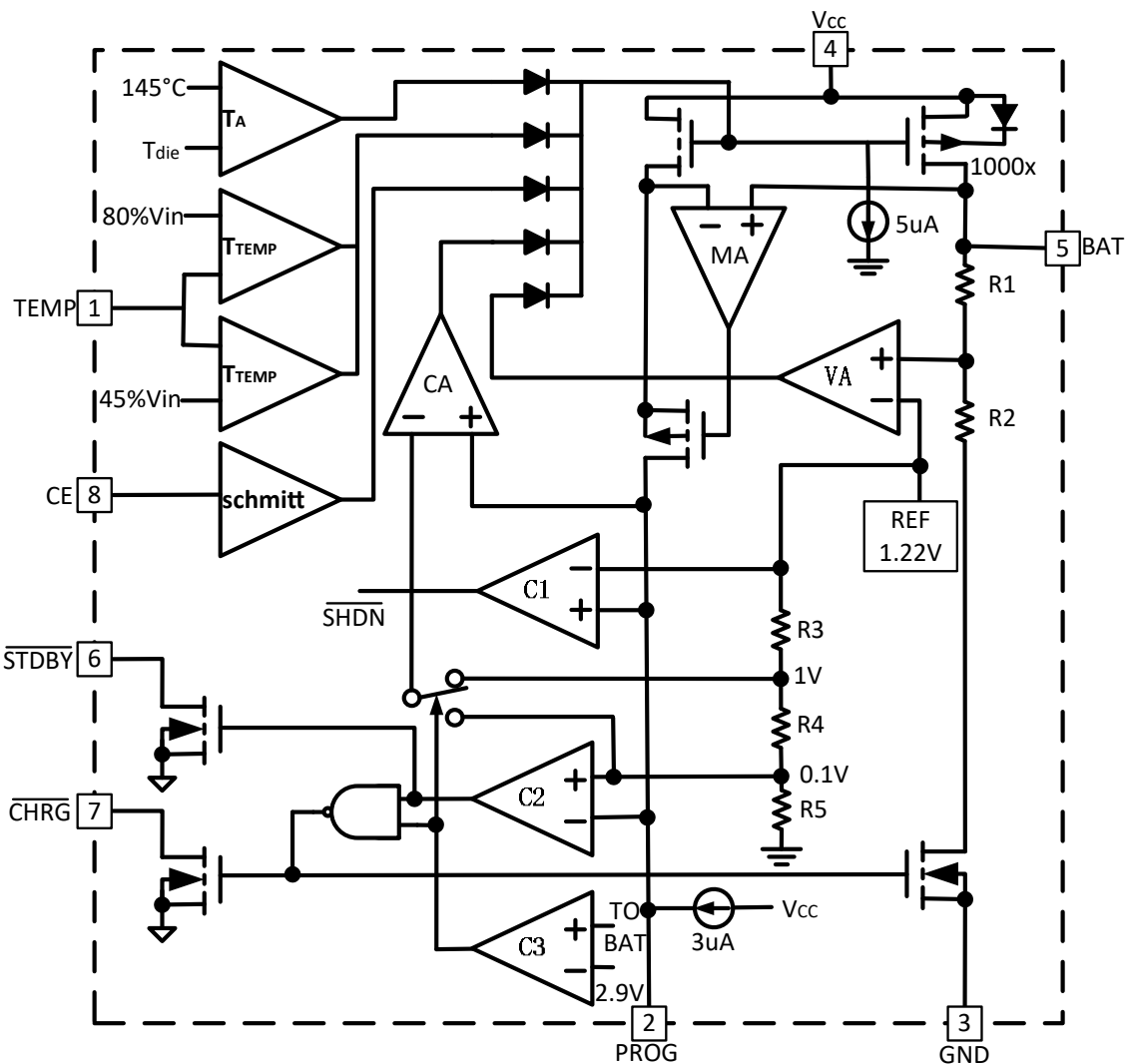

Figure 2 Pin Configuration of FC9056(Top View)

Function Block Diagram





FC9056

1A Stand alone Linear Li-Ion Battery Charger with Thermal Regulation

Pin Description

Pin Name	Pin Number	
TEMP	1	Connecting TEMP pin to NTC thermistor's output in Lithium ion battery pack. If TEMP pin's voltage is below 45% or above 80% of supply voltage VIN for more than 0.15S, this means that battery's temperature is too high or too low, charging is suspended. The temperature sense function can be disabled by grounding the TEMP pin.
PROG	2	charge current is set by connecting a resistor R _{PROG} from this pin to GND. When in precharge mode, the PROG pin's voltage is regulated to 0.2V. When in constant charge current mode, the PROG pin's voltage is regulated to 2V. In all modes during charging, the voltage on PROG pin can be used to measure the charge current as follows: $IBAT=(V_{PROG}/R_{PROG})*1000$ ----(FC9056)
GND	3	GND
Vcc	4	VIN is the power supply to the internal circuit. When VIN drops to within 30mv of the BAT pin voltage, FC9056 enters low power sleep mode, dropping BAT pin's current to less than 2uA
BAT	5	Connect the positive terminal of the battery to BAT pin. BAT pin draws less than 2uA current in chip disable mode or in sleep mode. BAT pin provides charge current to the battery and provides regulation voltage of 4.2V.
\overline{STDBY}	6	When the battery Charge Termination, the \overline{STDBY} pin is pulled low by an internal switch, otherwise \overline{STDBY} pin is in high impedance state.
\overline{CHRG}	7	When the battery is being charged, the \overline{CHRG} pin is pulled low by an internal switch, otherwise \overline{CHRG} pin is in high impedance state.
CE	8	A high input will put the device in the normal operating mode. Pulling the CE pin to low level will put the FC9056 into disable mode. The CE pin can be driven by TTL or CMOS logic level.

Ordering Information

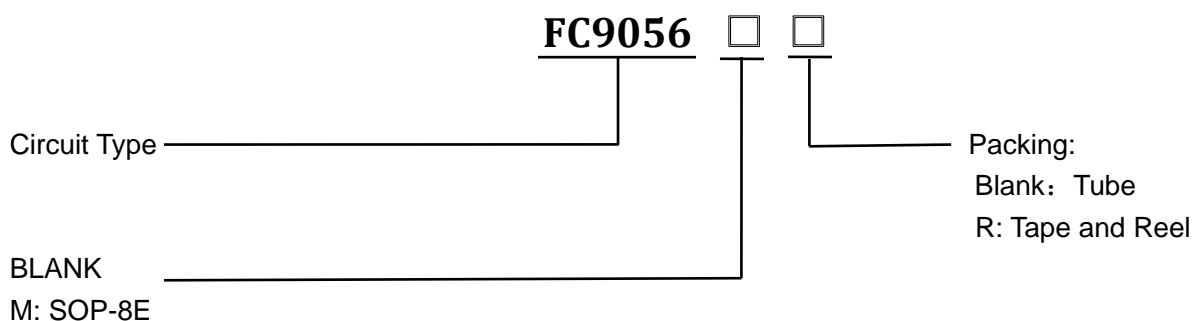



FC9056

1A Stand alone Linear Li-Ion Battery Charger with Thermal Regulation

Electrical Characteristics

(VIN = 5V, TA = 25°C unless otherwise specified)

Parameters	Symbol	Test Condition	Min.	Typ.	Max.	Unit
Input Supply Voltage	VCC		4.0	5.0	8.0	V
Input Supply Current	ICC	Charge Mode, R _{PROG} =1k Standby Mode(Charge Terminated) Shutdown Mode (R _{PROG} Not Connected, V _{CC} < V _{BAT} , or V _{CC} < V _{UV})		150 55 55	500 100 100	μA
Regulated Output (Float) Voltage	VFLOAL	0°C ≤ TA ≤ 85°C, IBAT=40mA	4.137	4.2	4.26	V
BAT Pin Current	IBAT	R _{PROG} = 2k, Current Mode R _{PROG} = 1k, Current Mode Standby Mode, V _{BAT} = 4.2V	450 950 0	500 1000 -2.5	550 1050 -2.6	mA mA uA
Trickle Charge Current	ITRIKL	V _{BAT} < V _{TRIKL} , R _{PROG} =1K	120	130	140	mA
Trickle Charge Threshold Voltage	VTRIKL	R _{PROG} =1K, V _{BAT} Rising	2.8	2.9	3.0	V
Trickle Charge Hysteresis Voltage	VTRHYS	R _{PROG} =1K	60	80	100	mv
Undervoltage	Vuv	V _{CC} increasing	3.5	3.7	3.9	V
PROG pin voltage	Vprog	R _{PROG} = 1k, Current Mode	0.9	1.0	1.1	V
CHRG pin voltage	V _{CHRG}	I _{CHRG} =5ma		0.3	0.6	V
STDBY pin voltage	V _{STDBY}	I _{STDBY} =5ma		0.3	0.6	V
Junction Temperature in Constant Temperature Mode	T _{L.M}			145		°C

1A Stand alone Linear Li-Ion Battery Charger with Thermal Regulation

Typical Performance Characteristics

Complete Charge Cycle (1000mAh Battery)

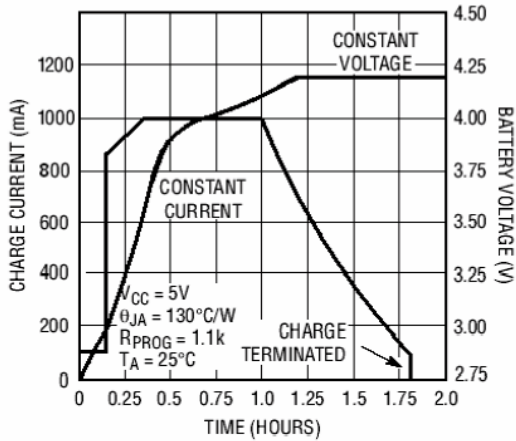

Typical Application Circuit

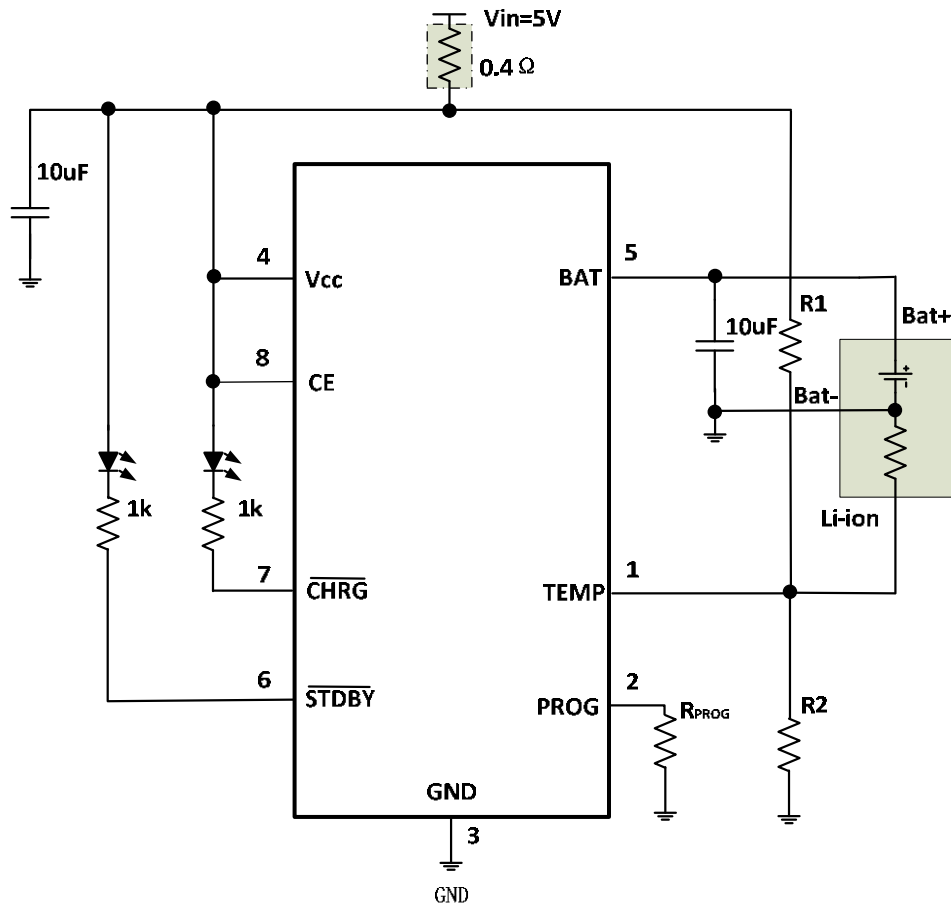

1A Stand alone Linear Li-Ion Battery Charger with Thermal Regulation

Function Description

Precharge Current

The FC9056 is a linear charger circuit specially designed for single cell lithium-ion batteries. When the FC9056 is powered with a battery connected, the IC first detects if the cell voltage is ready for full charge current. If the cell voltage is less than the prequal level (3V typ), the battery is precharged with a 55mA current until the cell reaches the proper level. The full charging current, as set by PROG pin, is then applied

Soft-Start

The FC9056 includes a soft-start function to control the rise rate of the charging current rising from zero to the fast-charging current level in constant current mode. During charger soft-start, the FC9056 ramps up the voltage on PROG pin with constant well-controlled slew rate. The charging current is proportional to the PROG voltage. The soft-start time is 20us (typical), which is independent of the fast-charging current level.

Charging Current Setting

The charge current is programmed by using a resistor from the PROG pin to the ground. The battery charge current is 1000 times the current out of the PROG pin. The battery charge current is calculated by the following equation:

$$I_{CHG} = V_{PROG} * 1000 / R_{PROG}$$

Where V_{PROG} is PROG regulation voltage (nominal=1V). The charging current set factor and the PROG regulation voltage are shown in the Electrical Characteristics. The PROG regulation voltage is reduced by thermal regulation function.

Battery Full Indication

Current mode charging stopped when I_{bat} falls to 10% of the current set by R_{PROG} and the charger is in voltage mode. After the FC9056 stopped current mode charging, it keeps operating in voltage mode without turning off the charger. When the PROG pin's voltage down to 100mv over 2ms, the charger will stop operating and the V_{cc} current down to 55uA.

Charge Status Outputs

The open-drain CHRG and STDBY outputs can be used to drive LED indicate four charger operations are shown in Table 1.

Charge state	Red LED (CHRG)	Green LED(STDBY)
charging	bright	extinguish
Charge Termination	extinguish	bright
Vin too low; Temperature of battery too low or too high; no battery	extinguish	extinguish
BAT PIN Connect 10u Capacitance; No battery	Extinguish (T=1-4s)	

Table1

External Thermistor Monitor (TEMP)

The FC9056 continuously detects the battery temperature by measuring the TEMP pin voltage. A NTC or PTC thermistor can parallel with R_2 to deviate the TEMP pin voltage. Internal of FC9056, V_{low} is preset to 45%* V_{cc} , V_{high} is preset to 80%* V_{cc} , The normal temperature voltage is, above V_{low} and below V_{high} . The TEMP Pin voltage must be within normal temperature voltage range, and then FC9056 can start working normally. If the TEMP pin voltage above V_{high} or below V_{low} , it means the temperature of the battery is too high or too low, the charger will be turn off.

The R_1 and R_2 can be derived from following equations:

For NTC Thermistors:

$$R_1 = \frac{R_{t1} * R_{th} * (K_2 - K_1)}{(R_{t1} - R_{th}) * K_1 * k_2}$$

$$R_2 = \frac{R_{t1} * R_{th} * (K_2 - K_1)}{R_{t1} * (K_1 - K_1 * K_2) - R_{th}(K_2 - k_1 * k_2)}$$

For PTC Thermistors:

$$R_1 = \frac{R_{t1} * R_{th} * (K_2 - K_1)}{(R_{th} - R_{t1}) * K_1 * k_2}$$

1A Stand alone Linear Li-Ion Battery Charger with Thermal Regulation

$$R2 = \frac{R_{t1} * R_{th} * (K_2 - K_1)}{R_{th} * (K_1 - K_1 * K_2) - R_{t1}(K_2 - K_1 * K_2)}$$

Where R_{t1} is the resistance value in lowest desired operation temperature and R_{th} is the resistance value in highest desired operation temperature, K_1 is 0.45, K_2 is 0.8. The resistances of thermistors are specified by the thermistor manufacturer. If the temperature monitoring function is not desired, there's an easy method to connect TEMP pin to GND to disable this function.

Increase the heat regulating current

Reduce the voltage drop across the internal MOSFET can significantly reduce the power consumption of the IC. During thermal regulation, this has an increased current supplied to the battery. One strategy is accomplished by an external element (e.g., a resistor or a diode) will be part of the power consumption.

Example: FC9056 is powered by a 5v AC adapter, it charge to one with a 3.75V voltage lithium-ion battery, and set the full-scale charge current 800mA by programming. Assuming θ_{JA} is 125 °C/W, at 25 °C ambient temperature conditions, the charging current is approximately:

$$I_{BAT} = \frac{145^\circ\text{C} - 25^\circ\text{C}}{(5\text{V} - 3.75\text{V}) \cdot 125^\circ\text{C/W}} = 768\text{ma}$$

Increase the voltage across the resistor in series with a 5V AC adapter(Figure 3), the on-chip power dissipation can be reduced, thereby increasing the heat regulating current:

$$I_{BAT} = \frac{145^\circ\text{C} - 25^\circ\text{C}}{(V_S - I_{BAT} R_{CC} - V_{BAT}) \cdot \theta_{JA}}$$

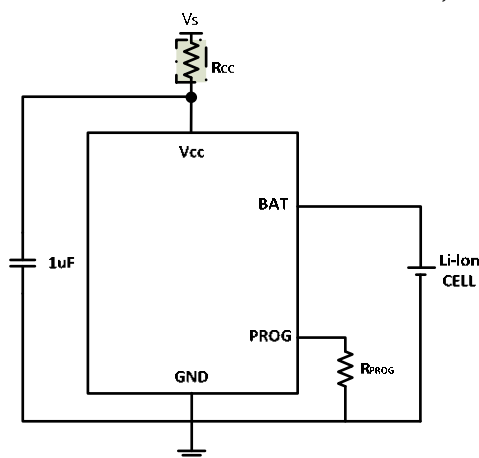

Figure 3: One kind of maximizing charge current thermal regulation circuit mode

Use the quadratic equation can be obtained I_{BAT}

$$I_{BAT} = \frac{(V_S - V_{BAT}) - \sqrt{(V_S - V_{BAT})^2 - \frac{4R_{CC}(145^\circ\text{C} - T_A)}{\theta_{JA}}}}{2R_{CC}}$$

Take $R_{CC}=0.25\Omega$, $V_S=5\text{V}$, $V_{BAT}=3.75\text{V}$, $T_A=25^\circ\text{C}$, and $\theta_{JA}=125^\circ\text{C/W}$, we can calculate the heat adjustment charge current: $I_{BAT} = 948\text{mA}$. The results shows that the structure can be full scale output 800mA charging current at higher ambient temperatures.

Although this application can deliver more energy to the battery in heat regulating mode and shorten the charging time, But in voltage mode, if VCC becomes low enough leaving FC9056 state at low voltage drop, It is actually possible to extend the charging time. Figure 4 shows how the circuit becomes large as the Rcc resulting voltage drop.

When in order to maintain a smaller component size and to avoid voltage drop leaving the Rcc values minimized, this technology can play a role in the best. Keep in mind: you should select a sufficient power handling capability resistor.

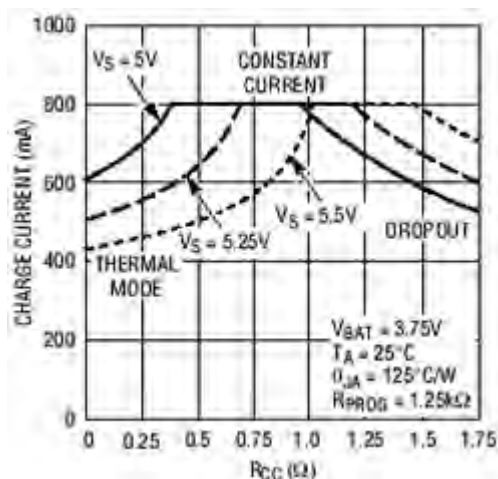

Figure 4: Charging current relationship with the RCC curve

Automatic restart

Once the charge cycle is terminated, FC9056 immediately adopt a comparator with 1.8ms filter time continuously monitor the BAT pin voltage. When the battery voltage drops below 4.05V or less (Generally corresponding to the battery capacity from 80 to 90%), charging cycle restart. This ensures that the battery is maintained at (or near) a full charge state, and eliminates the periodic need to

1A Stand alone Linear Li-Ion Battery Charger with Thermal Regulation

start charging cycle. A typical charge cycle state diagram is shown below.

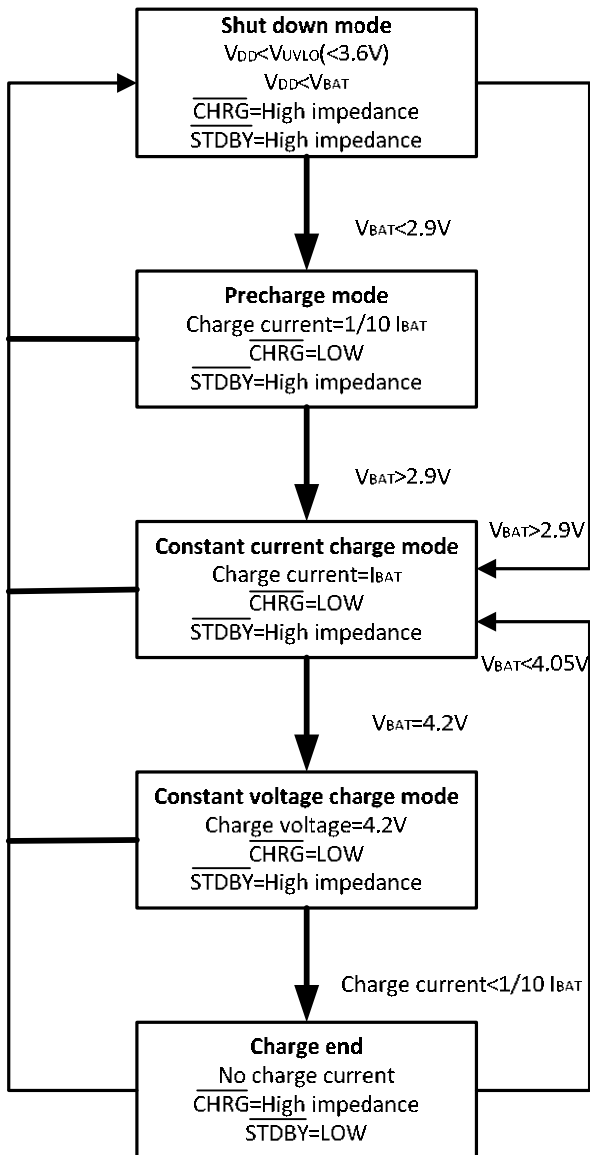

1A Stand alone Linear Li-Ion Battery Charger with Thermal Regulation

Package Information

SOP-8E Package Outline Dimensions

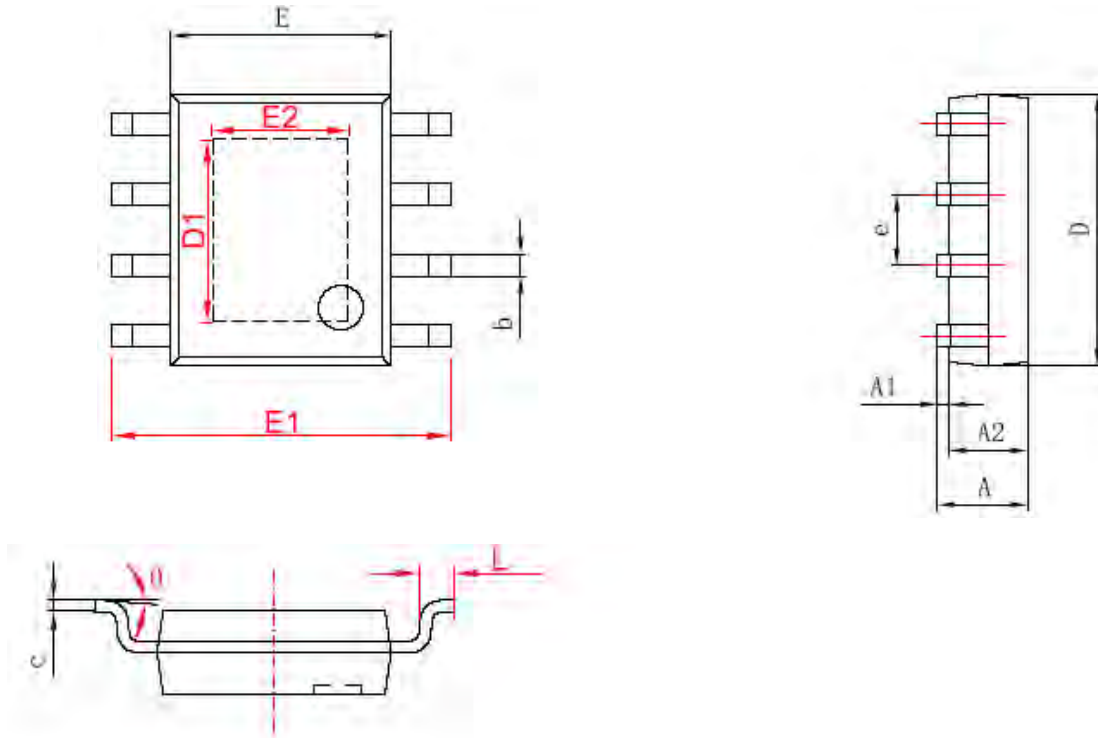

	Dimensions in Millimeters		Dimensions in Inches	
	Min	Max	Min	Max
A	1.350	1.750	0.053	0.069
A1	0.050	0.150	0.004	0.010
A2	1.350	1.550	0.053	0.061
b	0.330	0.510	0.013	0.020
c	0.170	0.250	0.006	0.010
D	4.700	5.100	0.185	0.200
D1	3.202	3.402	0.126	0.134
E	3.800	4.000	0.150	0.157
E1	5.800	6.200	0.228	0.244
E2	2.313	2.513	0.091	0.099
e	1.270 (BSC)		0.050 (BSC)	
L	0.400	1.270	0.016	0.050
θ	0°	8°	0°	8°