

General Description

The DW01C Lithium-ion/Polymer Battery protection IC is designed to protect lithium-ion/polymer battery from damage or degrading the lifetime due to over-charge, over-discharge, and/or overcurrent for one-cell lithium-ion/polymer battery powered systems, such as cellular phones.

The ultra-small package and less required external components make it ideal to integrate the DW01C into the limited space of battery pack. The accurate $\pm 50\text{mV}$ overcharging detection voltage ensures safe and full utilization charging. The very low standby current drains little current from the cell while in storage.

Features

- Reduction in Board Size due to Miniature Package SOT-23-6.
- Ultra-Low Quiescent Current at $2\mu\text{A}$ ($V_{\text{CC}}=3.5\text{V}$).
- Precision Overcharge Protection Voltage ($4.30\text{V} \pm 50\text{mV}$)
- Over-discharge Protection voltage between ($2.40\text{V} \pm 100\text{mV}$)
- Over-current Protection voltage between ($0.15\text{V} \pm 30\text{mV}$)
- Load Detection Function during Overcharge Mode.
- Two Detection Levels for Overcurrent Protection.
- -40°C to $+85^{\circ}\text{C}$ operating temperature range

Applications

Protection to One-Cell Lithium-Ion /Lithium-Polymer Battery Pack

Pin Configuration

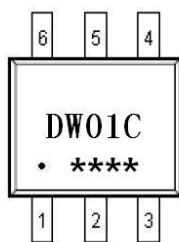

SOT23-6

Pin Name	Pin Number	Pin Function
DO	1	Discharge control output terminal
VM	2	Charge/discharge current detection input
CO	3	Charge control output terminal
NC	4	Not connected
V_{DD}	5	Power input
V_{SS}	6	Power ground terminal

Block Diagram

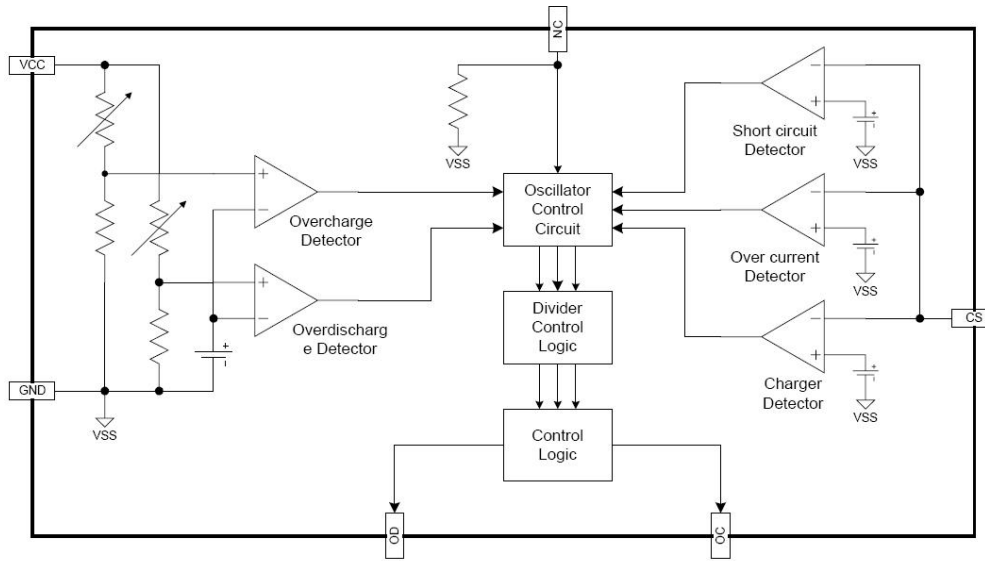

Typical Application

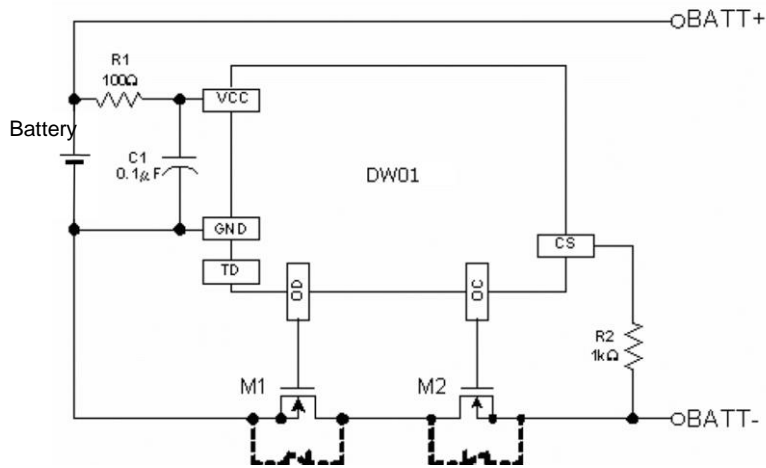

MOS FET : FTK8810L or FTK8810



Absolute Maximum Rating

(GND=0V, Ta=25°C unless otherwise specified)

Parameter	Symbol	Rating	Unit
Power supply	V _{DD}	-0.3~10	V
VM pin Input voltage	V _M	V _{DD} -28 to V _{DD} +0.3	V
OC output pin voltage	V _{CO}	V _{DD} -28 to V _{DD} +0.3	V
OD output pin voltage	V _{DO}	V _{DD} -0.3 to V _{DD} +0.3	V
Power Dissipation	P _D	625	mW
Operating Temperature	T _{opr}	-40 to +85	°C
Storage Temperature	T _{stg}	-55 to +125	°C
Junction Temperature	T _J	150	°C

Electrical Characteristics

(Ta=25°C unless otherwise specified)

Parameter	Symbol	Testing Conditions	Min.	Typ.	Max.	Unit
Supply Voltage	V _{CC}	---	1.5	---	9.0	V
Supply Current	I _{CC}	V _{CC} =3.5V		2.0	6.0	μA
Overcharge Protection Voltage	V _{OCP}	---	4.25	4.30	4.35	V
Overcharge Release Voltage	V _{OCR}	---	4.05	4.10	4.15	V
Over-discharge Protection Voltage	V _{ODP}	---	2.30	2.40	2.50	V
Over-discharge Release Voltage	V _{ODR}	---	2.90	3.00	3.10	V
Over current Protection Voltage	V _{OI1}	---	0.12	0.15	0.18	V
Short circuit Protection Voltage	V _{OI2}	V _{CC} =3.6V	0.80	1.30	1.75	V
Over current Reset Resistance	R _{SHORT}	V _{CC} =3.6V	50	100	150	kΩ
Charger Detection Threshold Voltage	V _{CH}	---	-0.8	-0.5	-0.2	V
Overcharge Delay Time	T _{OC}	V _{DD} =3.6V~4.4V	---	80	200	mS
Over-discharge Delay Time	T _{OD}	V _{DD} =3.6V~2.0V	---	40	120	mS
Overcurrent Delay Time (1)	T _{OI1}	V _{CC} =3.6V	5	10	20	mS
Overcurrent Delay Time (2)	T _{OI2}	V _{CC} =3.6V	---	50	120	mS
OD Pin Output "H" Voltage	V _{OH1}	---	V _{CC} -0.1	V _{CC} -0.02		V
OD Pin Output "L" Voltage	V _{OL}	---		0.1	0.5	V
OC Pin Output "H" Voltage	V _{OH2}	---	V _{CC} -0.1	V _{CC} -0.02		V
OC Pin Output "L" Voltage	V _{OL2}	---		0.1	0.5	V



Description of Operation

1. Normal Operation status

The DW01C will run in normal operation status when the battery voltage is in the range from over discharge protection voltage (V_{ODP}) to overcharge protection voltage (V_{OCP}), and the CS pin voltage is in the range from the Charger Detection Threshold Voltage (V_{CH}) to Over current Protection Voltage (V_{OIH}), Under this status, the charging MOSFET (M2) and discharging MOSFET (M1) are turned on so that charging and discharging can be carried out normally.

2. Overcharge status

When the battery voltage becomes higher than the overcharge protection voltage (V_{OCP}) during charging in the normal status and detection continues for the overcharge delay time (T_{OC}) or longer, the charging MOSFET (M2) will be turned off.

The overcharge status can be released in two cases:

- (1) In the case of battery self-discharge, when the battery voltage (V_{CC}) < Overcharge Release Voltage (V_{OCR}), the charging MOSFET (M2) is turned on and return to the normal status.
- (2) In the case when the charger is removed and the load is connected, when the battery voltage (V_{CC}) is in the range from over discharge release voltage (V_{OCR}) to overcharge protection voltage (V_{OCP}) and the V_{CS} pin voltage is higher than Over current Protection Voltage (V_{OIH}), the charging MOSFET (M2) is turned on and return to normal status.

3. Over discharge status

When the battery voltage becomes lower than the over discharge protection voltage (V_{ODP}) during discharging in the normal status and detection continues for the over discharge delay time (T_{OD}) or longer, the discharging MOSFET (M1) will be turned off.

4. Power-down mode after Over discharge

When over discharge occurs, the DW01C will enter into power-down mode, turning off all the timing generation and detection circuitry to reduce the quiescent current to $0.1\mu A$ ($V_{CC}=2.0V$). At the same time, the CS pin is pull -up to V_{CC} through an internal resistor.

5. Release from power-down mode

When the battery is in the over discharge status is connected to a charger, and provided that the CS pin voltage is lower than the Charger Detection Threshold Voltage (V_{CH}), the DW01C will release from power-down mode and turns on the discharging MOSFET (M1) when the battery voltage reaches the over discharge protection voltage (V_{ODP}) or higher.

6. Overcurrent / short circuit Protection

In the normal status, when the discharge current is too large, the CS pin voltage is higher than either V_{OIH} or V_{OIS} , and continues the

status longer than either T_{O11} or T_{O12} , the DW01C will turn off the discharging MOSFET (M1) and enter to overcurrent/short circuit status.

7. Release from overcurrent / short circuit status

Under the overcurrent / short-circuit status, the DW01C will turn on the discharging MOSFET (M1) and restore to normal operation status when the CS pin voltage is less than V_{O11} and either the load has been removed or the impedance between BATT + and BATT- is $>500K\Omega$.

Note: When the battery is installed to the protection circuit for the first time, the circuit may not enter into normal operation status, which causing the battery not able to discharge. When this phenomenon happens, simply short the CS to GND, the circuit will be back to normal.

Timing Diagram

Overcharge status → Load Discharging → Normal Operation status

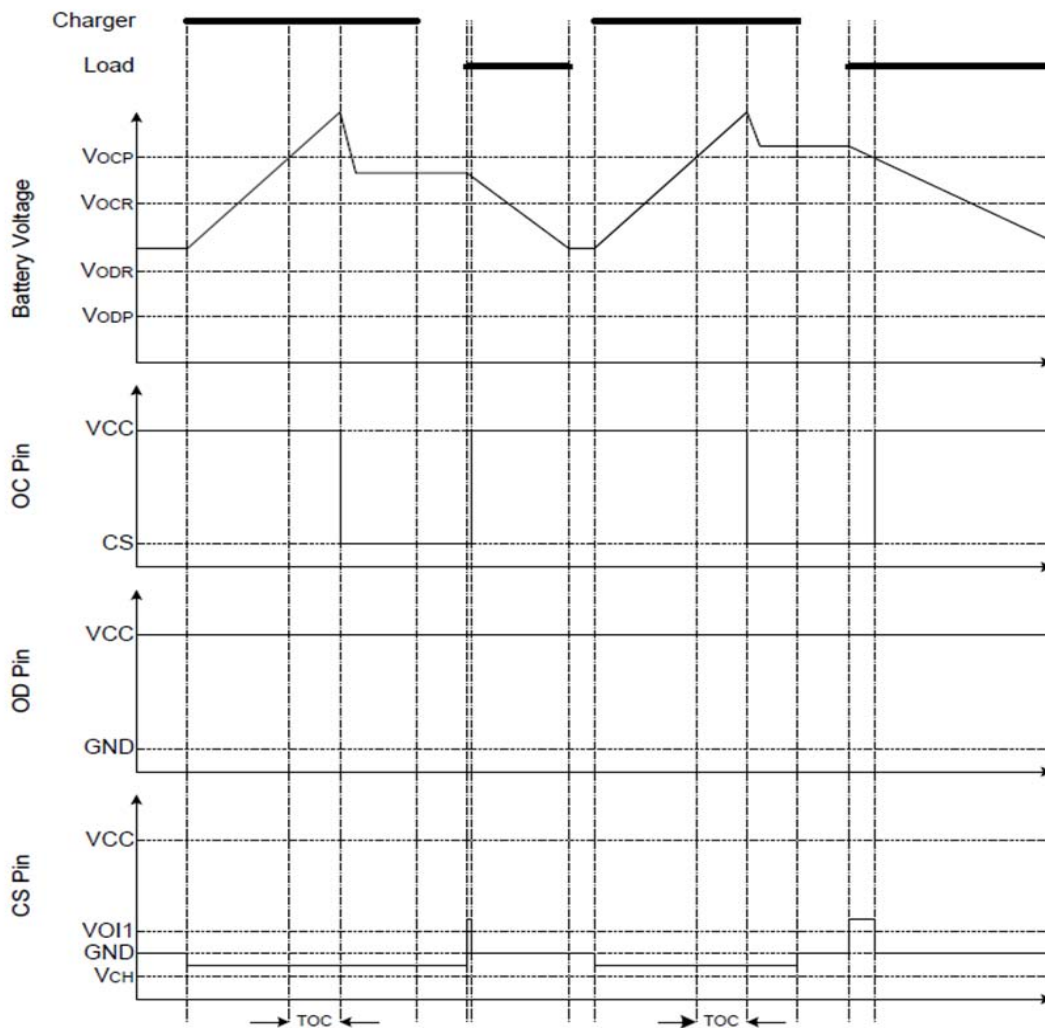

Over discharge Status → Charging by a Charger → Normal Operation Status

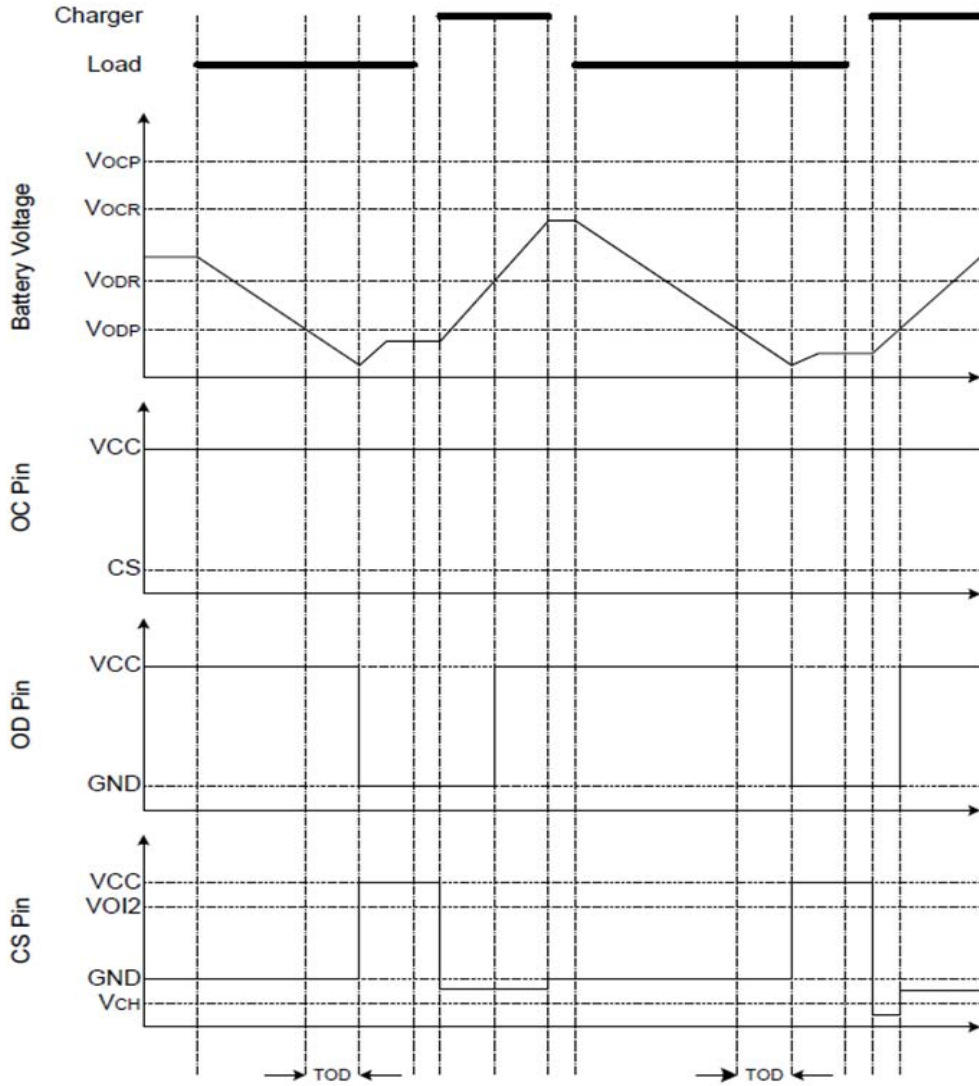

Over Current Status → Normal Operation Status

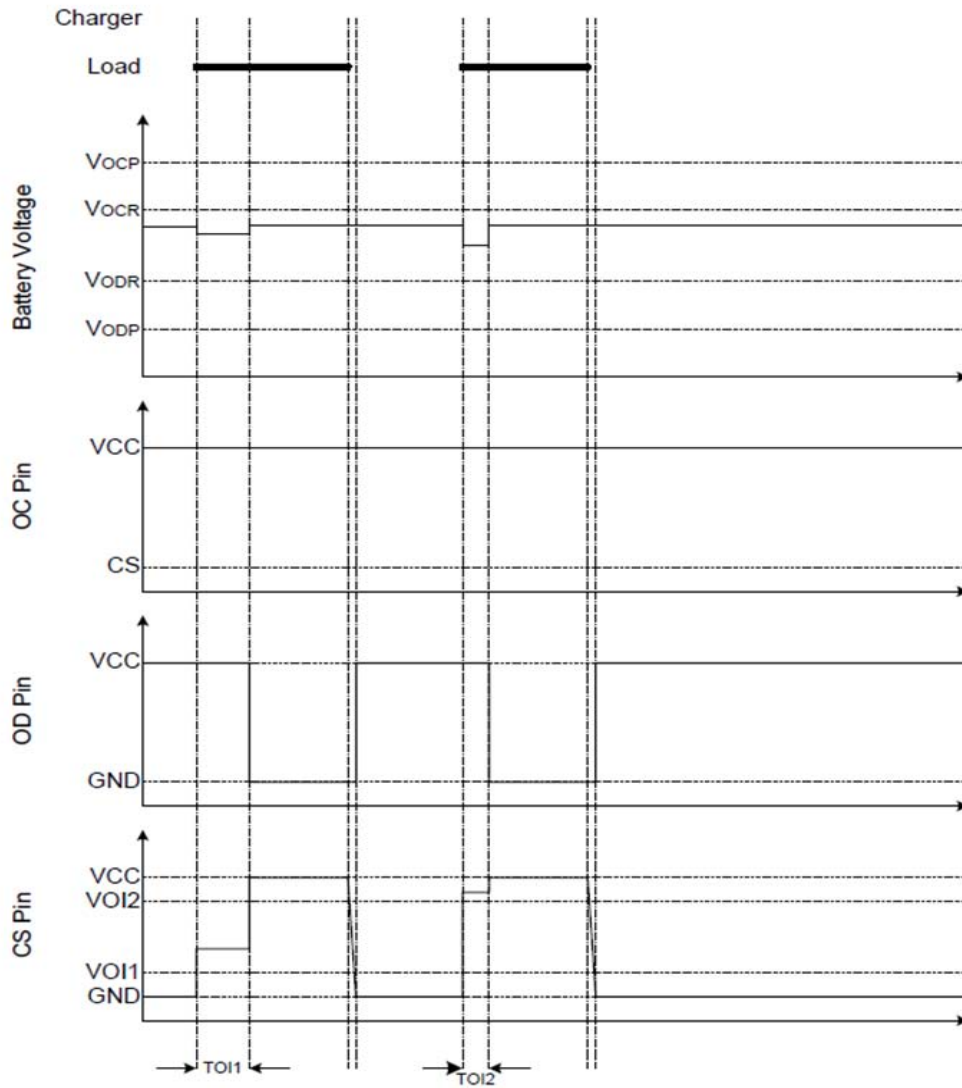

Package Dimensions

