

## PNP Transistor

### FEATURES

- Small Flat Package
- High Current Application
- High Voltage
- High Transition Frequency

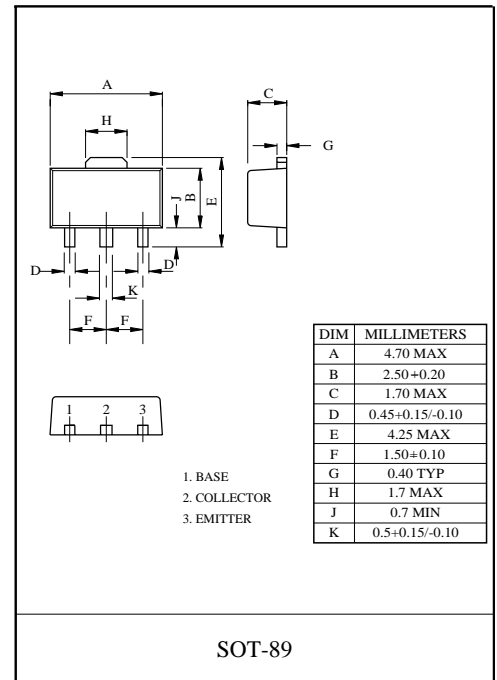

### MAXIMUM RATINGS ( $T_a=25^\circ\text{C}$ unless otherwise noted)

Symbol	Parameter	Value	Unit
$V_{CBO}$	Collector-Base Voltage	-120	V
$V_{CEO}$	Collector-Emitter Voltage	-120	V
$V_{EBO}$	Emitter-Base Voltage	-5	V
$I_C$	Collector Current	-0.8	A
$P_C$	Collector Power Dissipation	500	mW
$R_{\theta JA}$	Thermal Resistance From Junction To Ambient	250	$^\circ\text{C}/\text{W}$
$T_j$	Junction Temperature	150	$^\circ\text{C}$
$T_{stg}$	Storage Temperature	-55~+150	$^\circ\text{C}$

### ELECTRICAL CHARACTERISTICS ( $T_a=25^\circ\text{C}$ unless otherwise specified)

Parameter	Symbol	Test conditions	Min	Typ	Max	Unit
Collector-base breakdown voltage	$V_{(BR)CBO}$	$I_C = -1\text{mA}, I_E = 0$	-120			V
Collector-emitter breakdown voltage	$V_{(BR)CEO}$	$I_C = -10\text{mA}, I_B = 0$	-120			V
Emitter-base breakdown voltage	$V_{(BR)EBO}$	$I_E = -1\text{mA}, I_C = 0$	-5			V
Collector cut-off current	$I_{CBO}$	$V_{CB} = -120\text{V}, I_E = 0$			-100	nA
Emitter cut-off current	$I_{EBO}$	$V_{EB} = -5\text{V}, I_C = 0$			-100	nA
DC current gain	$h_{FE}$	$V_{CE} = -5\text{V}, I_C = -100\text{mA}$	80		240	
Collector-emitter saturation voltage	$V_{CE(sat)}$	$I_C = -500\text{mA}, I_B = -50\text{mA}$			-1	V
Base-emitter voltage	$V_{BE}$	$V_{CE} = -5\text{V}, I_C = -500\text{mA}$			-1	V
Collector output capacitance	$C_{ob}$	$V_{CB} = -10\text{V}, I_E = 0, f = 1\text{MHz}$			30	pF
Transition frequency	$f_T$	$V_{CE} = -5\text{V}, I_C = -0.1\text{A}, f = 30\text{MHz}$		120		MHz

### CLASSIFICATION OF $h_{FE}$

RANK	O	Y
RANGE	80 - 160	120 - 240
MARKING	DO	DY