

TRANSISTOR (PNP)

FEATURES

Power Dissipation:1.25W

Low Collector- emitter Saturation Voltage

MARKING:



Solid dot = Green molding compound device,
if none,the normal device.

SOT-223

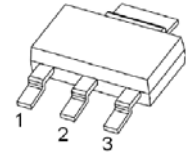

1. BASE
2. COLLECTOR
3. EMITTER

MAXIMUM RATINGS (T_a=25°C unless otherwise not)

Symbol	Parameter	Value	Unit
V _{CB0}	Collector- Base Voltage	- 40	V
V _{CEO}	Collector- Emitter Voltage	- 30	V
V _{EBO}	Emitter- Base Voltage	- 6	V
I _c	Collector Current - Continuous	- 3	A
P _C	Collector Dissipation	1.25	W
R _{θJA}	Thermal Resistance from Junction to Ambient	100	°C/W
T _J	JunctionTemperature	150	°C
T _{stg}	Storage Temperature	- 55~ +150	°C

ELECTRICAL CHARACTERISTICS (T_a=25°C unless otherwise specified)

Parameter	Symbol	Test conditions	Min	Typ	Max	Unit
Collector- base breakdown voltage	V _{(BR)CBO}	I _C =- 100μA , I _E =0	- 40			V
Collector- emitter breakdown voltage	V _{(BR)CEO}	I _C =- 10mA, I _B =0	- 30			V
Emitter- base breakdown voltage	V _{(BR)EBO}	I _E =- 100μA, I _C =0	- 6			V
Collector cut- off current	I _{CBO}	V _{CB} =- 40 V, I _E =0			- 1	μA
Collector cut- off current	I _{CEO}	V _{CE} =- 30V , I _B =0			- 10	μA
Emitter cut- off current	I _{EBO}	V _{EB} =- 6V, I _C =0			- 1	μA
DC current gain	h _{FE (1)}	V _{CE} =- 2V, I _C =- 1A	60		400	
	h _{FE (2)}	V _{CE} =- 2V, I _C =- 100mA	32			
Collector- emitter saturation voltage	V _{CE(sat)}	I _C =- 2A, I _B =- 0.2A			- 0.5	V
Base- emitter saturation voltage	V _{BE(sat)}	I _C =- 2A, I _B =- 0.2A			- 1.5	V
Transition frequency	f _T	V _{CE} =- 5V, I _C =- 0.1A f=10MHz	50			MHz

CLASSIFICATION of h_{FE(1)}

Rank	R	O	Y	GR
Range	60- 120	100- 200	160- 320	200- 400

Typical Characteristics

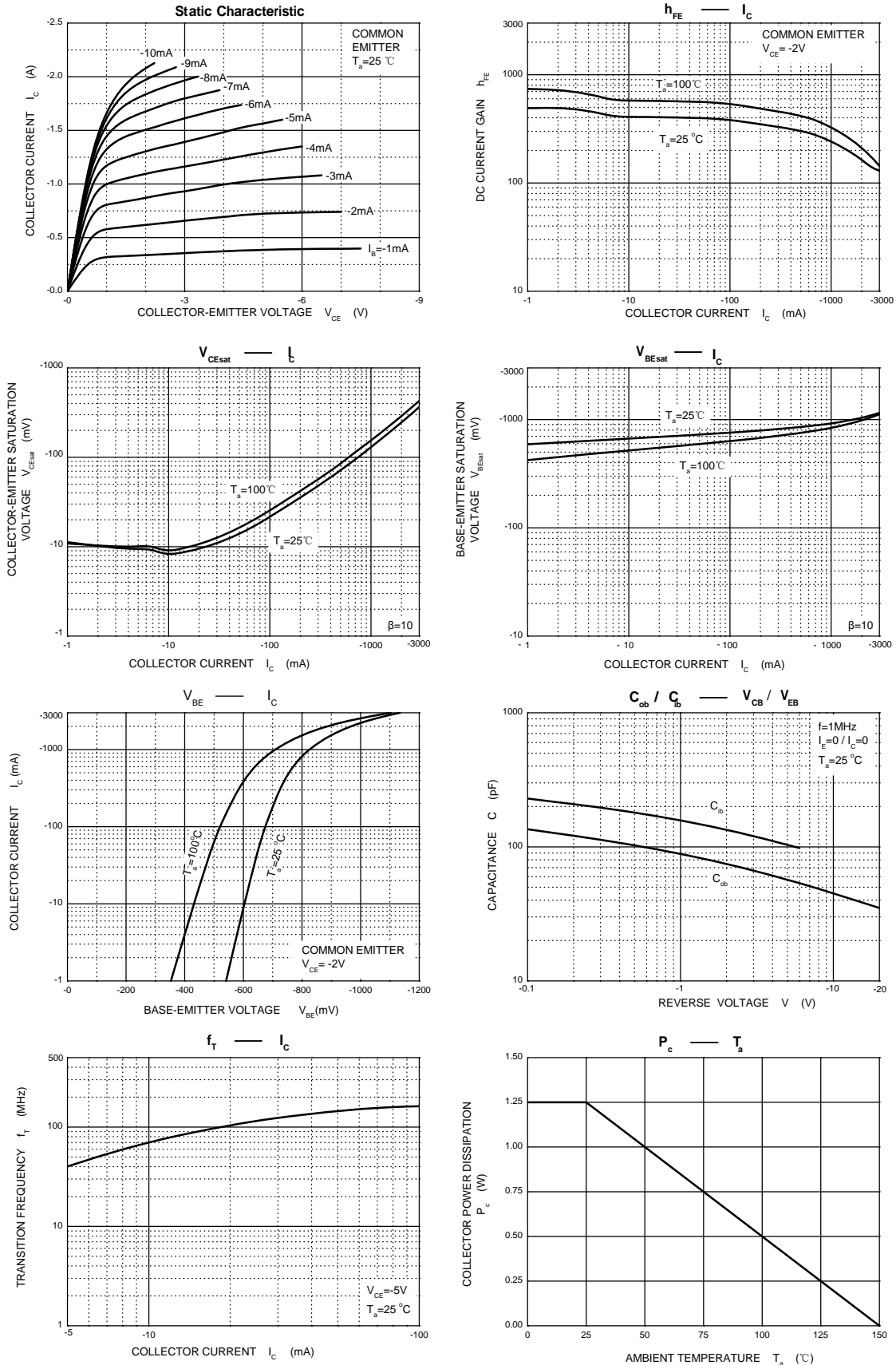

SOT-223 Package Outline Dimensions

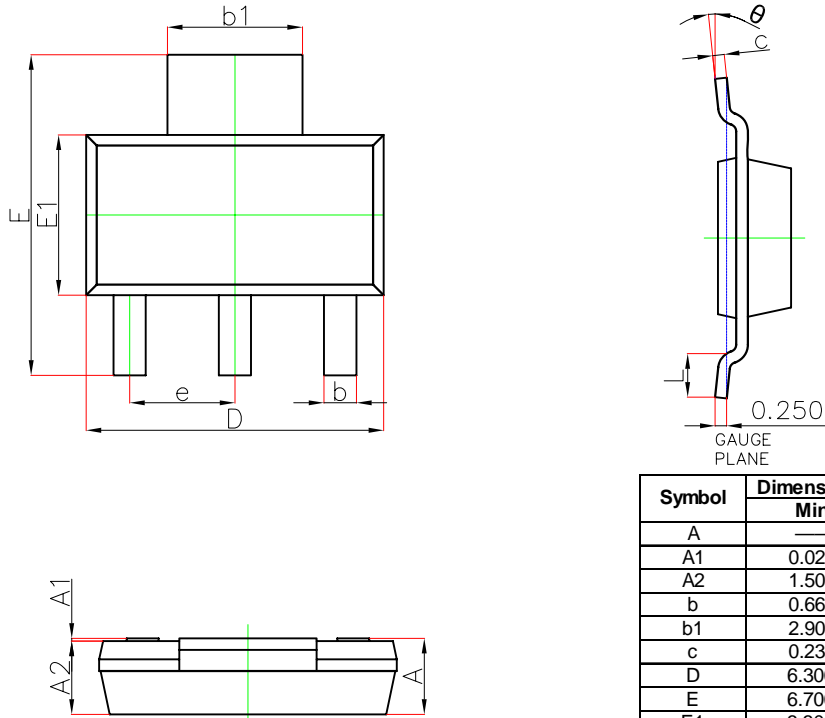

Symbol	Dimensions In Millimeters		Dimensions In Inches	
	Min.	Max.	Min.	Max.
A	—	1.800	—	0.071
A1	0.020	0.100	0.001	0.004
A2	1.500	1.700	0.059	0.067
b	0.660	0.840	0.026	0.033
b1	2.900	3.100	0.114	0.122
c	0.230	0.350	0.009	0.014
D	6.300	6.700	0.248	0.264
E	6.700	7.300	0.264	0.287
E1	3.300	3.700	0.130	0.146
e	2.300(BSC)		0.091(BSC)	
L	0.750	—	0.030	—
θ	0°	10°	0°	10°

SOT-223 Suggested Pad Layout

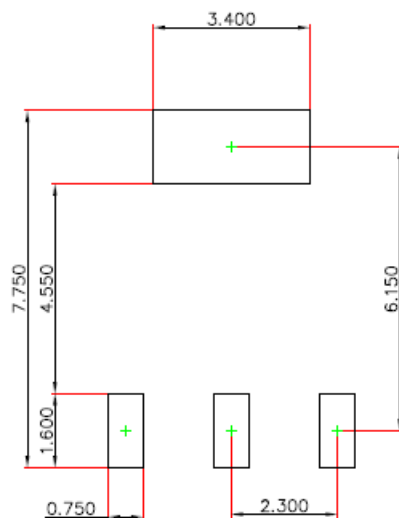

Note:

1. Controlling dimension: in millimeters.
2. General tolerance: ± 0.050 mm.
3. The pad layout is for reference purposes only.