

FEATURES

Audio power amplifier

Complementary to FTA928A

MAXIMUM RATINGS (T_A=25°C unless otherwise noted)

Symbol	Parameter	Value	Units
V _{CB0}	Collector-Base Voltage	30	V
V _{CEO}	Collector-Emitter Voltage	30	V
V _{EBO}	Emitter-Base Voltage	5	V
I _C	Collector Current -Continuous	2	A
P _C	Collector Power Dissipation	1	W
T _J	Junction Temperature	150	°C
T _{stg}	Storage Temperature	-55-150	°C

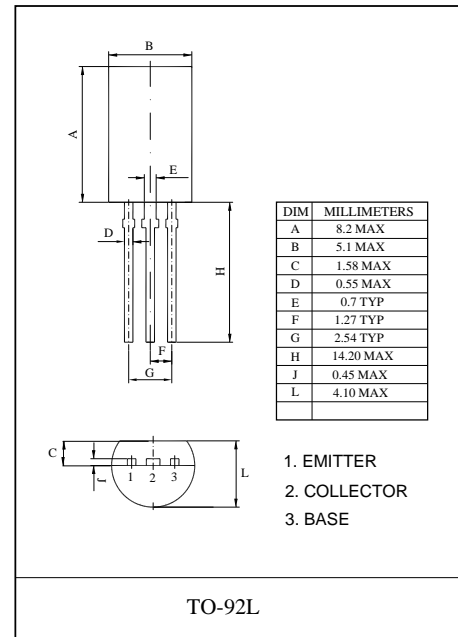

ELECTRICAL CHARACTERISTICS (T_{amb}=25°C unless otherwise specified)

Parameter	Symbol	Test conditions	MIN	TYP	MAX	UNIT
Collector-base breakdown voltage	V(BR) _{CBO}	I _C = 1mA, I _E =0	30			V
Collector-emitter breakdown voltage	V(BR) _{CEO}	I _C = 10mA, I _B =0	30			V
Emitter-base breakdown voltage	V(BR) _{EBO}	I _E = 1mA, I _C =0	5			V
Collector cut-off current	I _{CBO}	V _{CB} = 30V, I _E =0			0.1	μA
Emitter cut-off current	I _{EBO}	V _{EB} = 5V, I _C =0			0.1	μA
DC current gain	h _{FE}	V _{CE} = 2 V, I _C = 500 mA	100		320	
Collector-emitter saturation voltage	V _{CE} (sat)	I _C = 1.5A, I _B = 30 mA			2.0	V
Base-emitter voltage	V _{BE}	V _{CE} =2V, I _C = 500mA			1.0	V
Transition frequency	f _T	V _{CE} = 2 V, I _C = 500mA		120		MHz
Collector Output Capacitance	C _{ob}	V _{CB} =10V, I _E =0, f=1MHz		13		pF

CLASSIFICATION OF h_{FE}

Rank	O	Y
Range	100-200	160-320



FTC2328A

