

### FTC4377 TRANSISTOR (NPN)

#### FEATURES

Low voltage  
Low  $V_{ce(sat)}$  : 0.5V Max ( $I_C=2A$ ,  $I_B=0.05A$ )

#### MAXIMUM RATINGS ( $T_a=25^\circ\text{C}$ unless otherwise noted)

Symbol	Parameter	Value	Unit
$V_{CBO}$	Collector-Base Voltage	30	V
$V_{CEO}$	Collector-Emitter Voltage	10	V
$V_{EBO}$	Emitter-Base Voltage	6	V
$I_C$	Collector Current -Continuous	2	A
$P_C$	Collector Power Dissipation	0.5	W
$T_J$	Junction Temperature	150	$^\circ\text{C}$
$T_{stg}$	Storage Temperature	-55~150	$^\circ\text{C}$

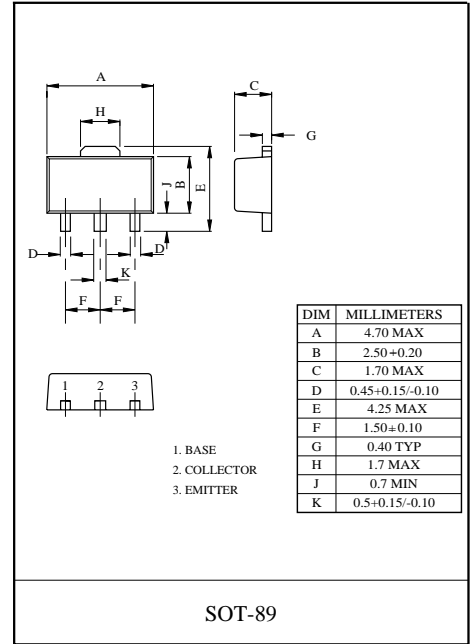

#### ELECTRICAL CHARACTERISTICS ( $T_a=25^\circ\text{C}$ unless otherwise specified)

Parameter	Symbol	Test conditions	Min	Typ	Max	Unit
Collector-base breakdown voltage	$V_{(BR)CBO}$	$I_C=1\text{mA}, I_E=0$	30			V
Collector-emitter breakdown voltage	$V_{(BR)CEO}$	$I_C=10\text{mA}, I_B=0$	10			V
Emitter-base breakdown voltage	$V_{(BR)EBO}$	$I_E=1\text{mA}, I_C=0$	6			V
Collector cut-off current	$I_{CBO}$	$V_{CB}=30\text{V}, I_E=0$			0.1	$\mu\text{A}$
Emitter cut-off current	$I_{EBO}$	$V_{EB}=6\text{V}, I_C=0$			0.1	$\mu\text{A}$
DC current gain	$h_{FE(1)}$	$V_{CE}=1\text{V}, I_C=0.5\text{A}$	140		600	
	$h_{FE(2)}$	$V_{CE}=1\text{V}, I_C=2\text{A}$	70			
Collector-emitter saturation voltage	$V_{CE(sat)}$	$I_C=2\text{A}, I_B=50\text{mA}$			0.5	V
Base-emitter voltage	$V_{BE}$	$V_{CE}=1\text{V}, I_C=2\text{A}$			1.5	V
Transition frequency	$f_T$	$V_{CE}=1\text{V}, I_C=0.5\text{A}$		150		MHz
Collector output capacitance	$C_{ob}$	$V_{CB}=10\text{V}, I_E=0, f=1\text{MHz}$		27		pF

#### CLASSIFICATION OF $h_{FE(1)}$

Rank	A	B	C	D
Range	140-240	200-330	300-450	420-600
Marking	SA	SB	SC	SD

## Typical Characteristics

