

General Purpose Transistors

NPN Silicon

- We declare that the material of product compliance with RoHS requirements.
- AEC-Q101 qualified
- Absolute maximum ratings (Ta=25°C)

Parameter	Symbol	Limits	Unit
Collector-base voltage	V _{CBO}	60	V
Collector-emitter voltage	V _{CEO}	50	V
Emitter-base voltage	V _{EB0}	7	V
Collector current	I _C	0.15	A
Collector power dissipation	P _C	0.15	W
Junction temperature	T _j	150	°C
Storage temperature	T _{stg}	-55~+150	°C

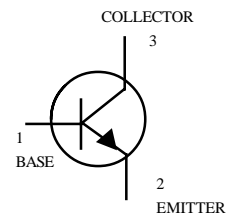
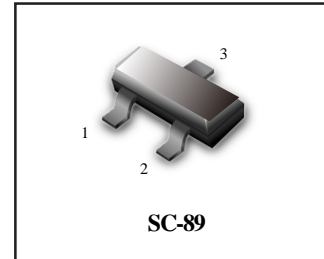

- Electrical characteristics (Ta=25°C)

Parameter	Symbol	Min.	Typ.	Max.	Unit	Conditions
Collector-base breakdown voltage	BV _{CBO}	60	-	-	V	I _C =50μA
Collector-emitter breakdown voltage	BV _{CEO}	50	-	-	V	I _C =1μA
Emitter-base breakdown voltage	BV _{EB0}	7	-	-	V	I _E =50μA
Collector cutoff current	I _{CBO}	-	-	0.1	μA	V _{CB} =60V
Emitter cutoff current	I _{EB0}	-	-	0.1	μA	V _{EB} =7V
Collector-emitter saturation voltage	V _{CE(sat)}	-	-	0.5	V	I _C /I _B =50mA/5mA
DC current transfer ratio	h _{FE}	120	-	560	-	V _{CE} =6V, I _C =1mA
Transition frequency	f _T	-	180	-	MHz	V _{CE} =12V, I _E =2mA, f=30MHz
Output capacitance	C _{ob}	-	2.0	3.5	pF	V _{CB} =12V, I _E =0A, f=1MHz

- Device marking

FTC4617QT1=BQ	FTC4617RT1=BR	FTC4617ST1=BS
---------------	---------------	---------------

- h_{FE} values are classified as follows :

Item	Q	R	S
h _{FE}	120~270	180~390	270~560

ORDERING INFORMATION

Device	Marking	Shipping
FTC4617QT1	BQ	3000 Tape & Reel
FTC4617QT3	BQ	10000 Tape & Reel
FTC4617RT1	BR	3000 Tape & Reel
FTC4617RT3	BR	10000 Tape & Reel
FTC4617ST1	BS	3000 Tape & Reel
FTC4617ST3	BS	10000 Tape & Reel

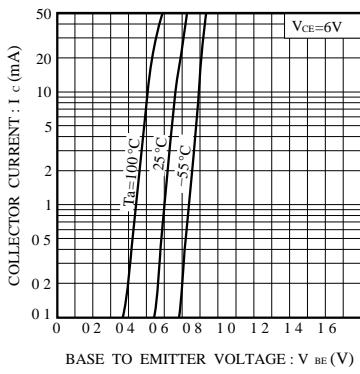

Fig.1 Grounded emitter propagation characteristics

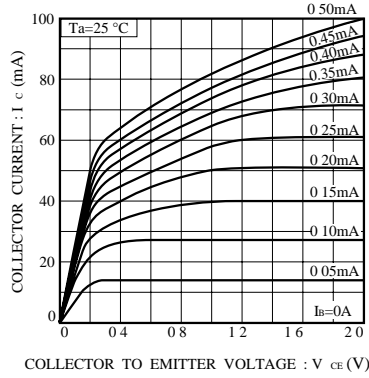

Fig.2 Grounded emitter output characteristics (I)

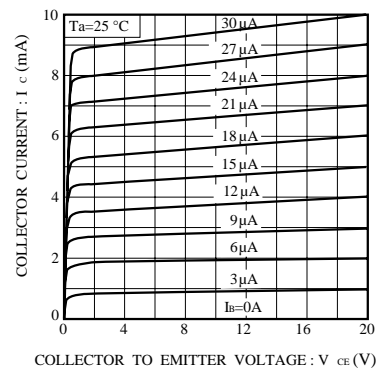

Fig.3 Grounded emitter output characteristics (II)

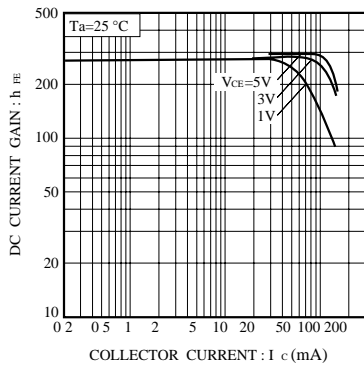

Fig.4 DC current gain vs. collector current (I)

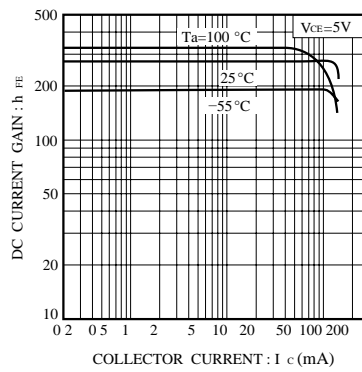

Fig.5 DC current gain vs. collector current (II)

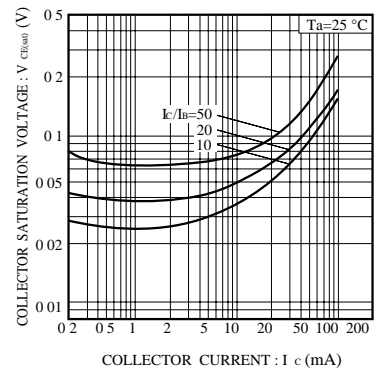

Fig.6 Collector-emitter saturation voltage vs. collector current

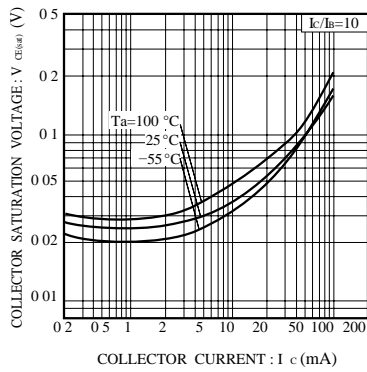

Fig.7 Collector-emitter saturation voltage vs. collector current (I)

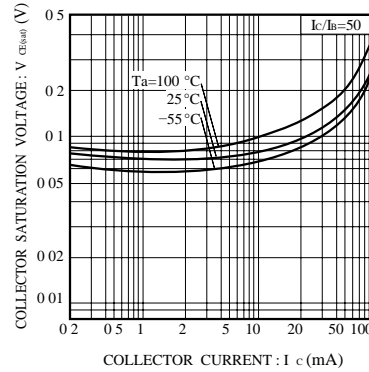

Fig.8 Collector-emitter saturation voltage vs. collector current (II)

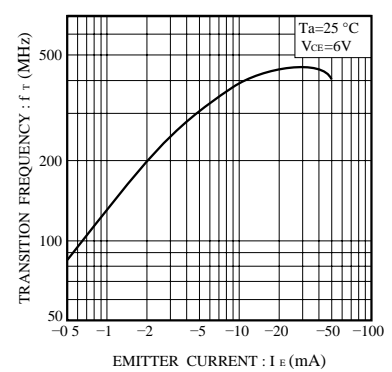

Fig.9 Gain bandwidth product vs. emitter current

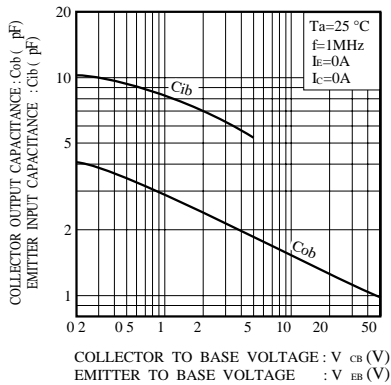

Fig.10 Collector output capacitance vs. collector-base voltage
Emitter input capacitance vs. emitter-base voltage

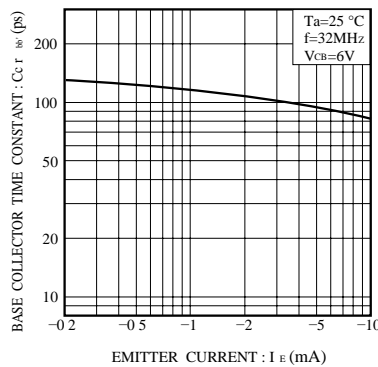
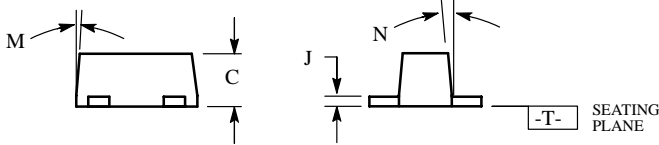
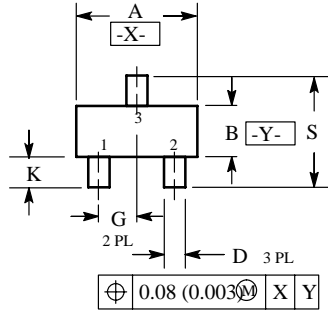

Fig.11 Base-collector time constant vs. emitter current

SC-89



NOTES:

- 1 DIMENSIONING AND TOLERANCING PER ANSI Y14.5M, 1982
- 2 CONTROLLING DIMENSION: MILLIMETERS
- 3 MAXIMUM LEAD THICKNESS INCLUDES LEAD FINISH THICKNESS. MINIMUM LEAD THICKNESS IS THE MINIMUM THICKNESS OF BASE MATERIAL.
- 4 463C-01 OBSOLETE, NEW STANDARD 463C-02

DIM	MILLIMETERS			INCHES		
	MIN	NOM	MAX	MIN	NOM	MAX
A	1.50	1.60	1.70	0.059	0.063	0.067
B	0.75	0.85	0.95	0.030	0.034	0.040
C	0.60	0.70	0.80	0.024	0.028	0.031
D	0.23	0.28	0.33	0.009	0.011	0.013
G	0.50 BSC			0.020 BSC		
H	0.53 REF			0.021 REF		
J	0.10	0.15	0.20	0.004	0.006	0.008
K	0.30	0.40	0.50	0.012	0.016	0.020
L	1.10 REF			0.043 REF		
M	---	---	10°	---	---	10°
N	---	---	10°	---	---	10°
S	1.50	1.60	1.70	0.059	0.063	0.067

