

NPN EPITAXIAL SILICON TRANSISTOR
HIGH POWER AMPLIFIER APPLICATION

FEATURES

- *Recommended for 45~ 50W Audio Frequency Amplifier Output Stage.
- *Complementary to 2SB688.

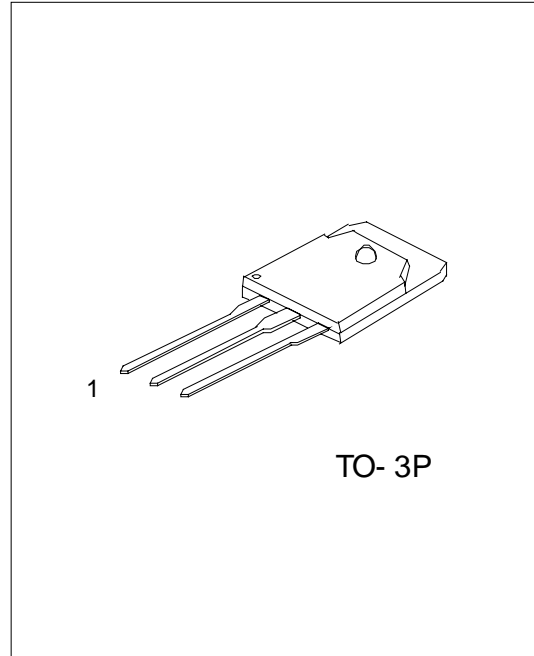

1: BASE 2:COLLECTOR 3: EMITTER

ABSOLUTE MAXIMUM RATINGS (Ta=25°C)

PARAMETER	SYMBOL	RATINGS	UNIT
Collector-Base Voltage	V _{CB0}	120	V
Collector-Emitter Voltage	V _{CEO}	120	V
Emitter-Base Voltage	V _{EBO}	5	V
Collector Current	I _c	10	A
Base Current	I _B	1	A
Collector Power Dissipation (T _c =25°C)	P _c	80	W
Junction Temperature	T _j	150	°C
Storage Temperature Range	T _{stg}	- 55 ~ 150	°C

ELECTRICAL CHARACTERISTICS (Ta=25°C, unless otherwise specified))

PARAMETER	SYMBOL	TEST CONDITION	MIN	TYP	MAX	UNIT
Collector- Emitter Breakdown Voltage	V _{(BR)CEO}	I _c =50mA, b=0	120			V
Collector Cut- off Current	I _{CB0}	V _{CB} =120V, I _E =0			10	μ A
Emitter Cut- off Current	I _{EBO}	V _{EB} =5V, I _c =0			10	μ A
DC Current Gain	h _{FE}	V _{CE} =5V, I _c =1A	55		160	
Collector- Emitter Saturation Voltage	V _{CE(sat)}	I _c =6A, b=0.6A			2.0	V
Base- Emitter Voltage	V _{BE}	V _{CE} =5V, I _c =5A			1.5	V
Transition Frequency	T _f	V _{CE} =5V, I _c =1A		12		MHz
Collector Output Capacitance	C _{ob}	V _{CB} =10V, I _E =0, f=1MHz		170		pF

CLASSIFICATION OF h_{FE}

RANK	R	O
RANGE	55-110	80-160



2SD718

