

Silicon NPN Power Transistors

DESCRIPTION

- With TO-126 package
- DARLINGTON

APPLICATIONS

- For medium power linear and switching applications

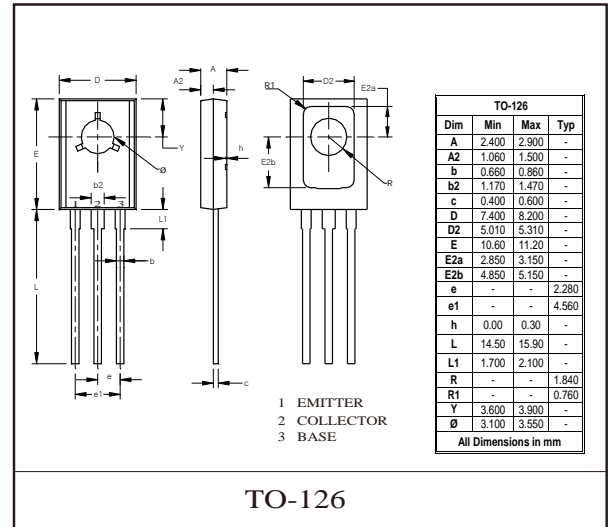

Absolute maximum ratings (Ta=25 °C)

SYMBOL	PARAMETER	CONDITIONS	VALUE	UNIT
V_{CBO}	Collector-base voltage	BD675A	45	V
		BD677A	60	
		BD679A	80	
		BD681	100	
V_{CEO}	Collector-emitter voltage	BD675A	45	V
		BD677A	60	
		BD679A	80	
		BD681	100	
V_{EBO}	Emitter -base voltage	Open collector	5	V
I_C	Collector current		4	A
I_{CM}	Collector current-Peak		6	A
I_B	Base current		0.1	A
P_C	Collector power dissipation	$T_C=25^\circ C$	40	W
T_j	Junction temperature		150	°C
T_{stg}	Storage temperature		-65~150	°C



BD675A/677A/679A/681

CHARACTERISTICS (T_j=25 °C unless otherwise specified)

SYMBOL	PARAMETER		CONDITIONS	MIN	TYP	MAX	UNIT
V _{CEO(SUS)}	Collector-emitter sustaining voltage	BD675A	I _C =50mA; I _B =0	45			V
		BD677A		60			
		BD679A		80			
		BD681		100			
V _{CEsat}	Collector-emitter saturation voltage	BD675A/677A/679A	I _C =2A; I _B =40mA			2.8	V
		BD681	I _C =1.5A; I _B =30mA			2.5	
V _{BE(ON)}	Base-emitter voltage	BD675A/677A/679A	I _C =2A; V _{CE} =3V			2.5	V
		BD681	I _C =1.5A; V _{CE} =3V			2.5	
I _{CBO}	Collector cut-off current	BD675A	V _{CB} =45V; I _E =0			0.2	mA
		BD677A	V _{CB} =60V; I _E =0				
		BD679A	V _{CB} =80V; I _E =0				
		BD681	V _{CB} =100V; I _E =0				
I _{CEO}	Collector cut-off current	BD675A	V _{CE} =45V; V _{BE} =0			0.5	mA
		BD677A	V _{CE} =60V; V _{BE} =0				
		BD679A	V _{CE} =80V; V _{BE} =0				
		BD681	V _{CE} =100V; V _{BE} =0				
I _{EBO}	Emitter cut-off current		V _{EB} =5V; I _C =0			2	mA
h _{FE}	DC current gain	BD675A/677A/679A	I _C =2A; V _{CE} =3V	750			
		BD681	I _C =1.5A; V _{CE} =3V	750			

Typical Characteristics

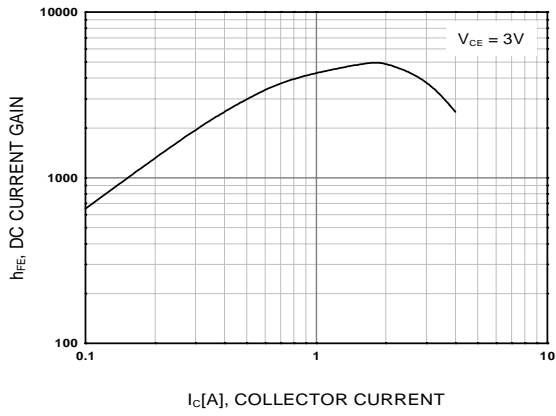

Figure 1. DC current Gain

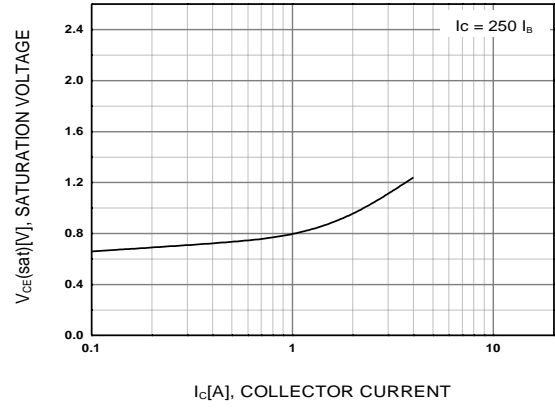

Figure 2. Collector-Emitter Saturation Voltage

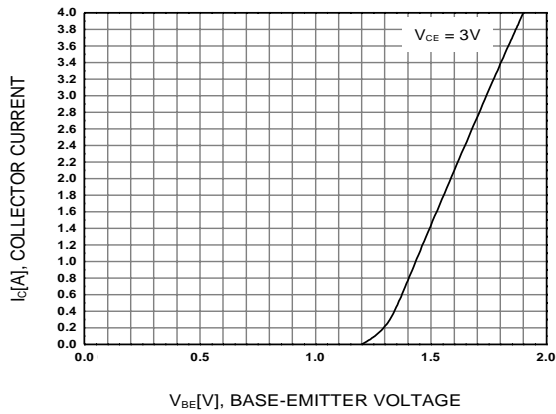

Figure 3. Base-Emitter On Voltage

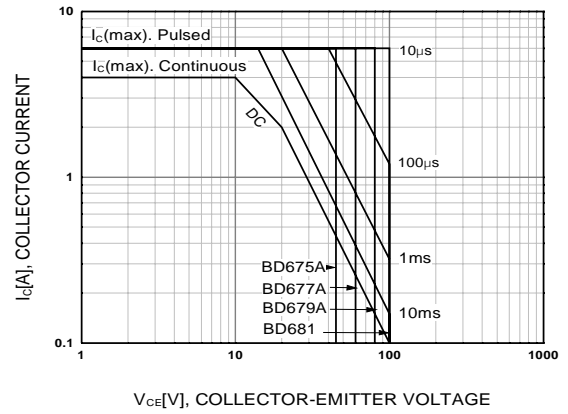

Figure 4. Safe Operating Area

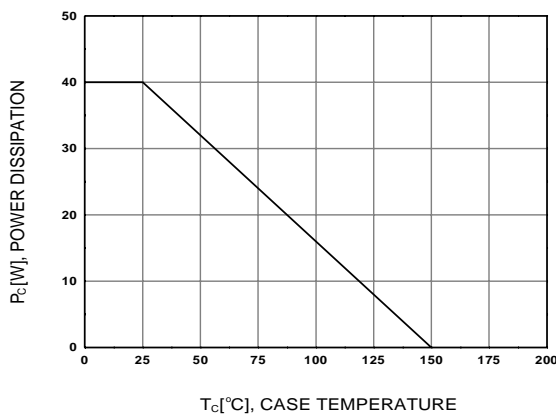

Figure 5. Power Derating