

Dual General Purpose Transistors

The FFB3946D device is a spin-off of our popular SOT-23/SOT-323 three-leaded device. It is designed for general purpose amplifier applications and is housed in the SOT-363 six-leaded surface mount package. By putting two discrete devices in one package, this device is ideal for low-power surface mount applications where board space is at a premium.

- h_{FE} , 100–300
- Low $V_{CE(sat)}$, ≤ 0.4 V
- Simplifies Circuit Design
- Reduces Board Space
- Reduces Component Count
- Available in 8 mm, 7-inch/3,000 Unit Tape and Reel

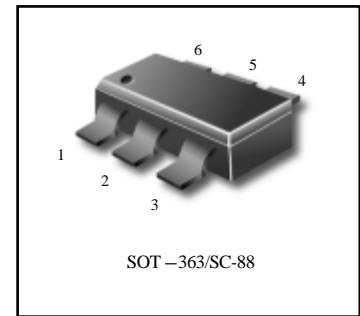

We declare that the material of product compliance with RoHS requirements.

MAXIMUM RATINGS

Rating	Symbol	Value	Unit
Collector-Emitter Voltage (NPN)	V_{CEO}	40	Vdc
(PNP)		-40	
Collector-Base Voltage (NPN)	V_{CBO}	60	Vdc
(PNP)		-40	
Emitter-Base Voltage (NPN)	V_{EBO}	6.0	Vdc
(PNP)		-5.0	
Collector Current-Continuous (NPN)	I_C	200	mA
(PNP)		-200	
Electrostatic Discharge	E_{SD}	HBM>16000, MM>2000	V

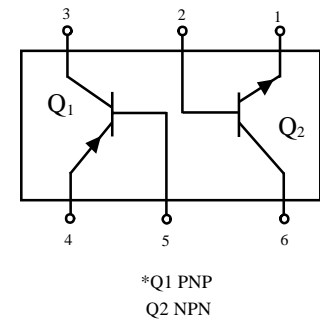

ORDERING INFORMATION

Device	Marking	Shipping
FFB3946DW1T1G	46	3000Units/Reel
FFB3946DW1T3G	46	10000Units/Reel

THERMAL CHARACTERISTICS

Characteristic	Symbol	Max	Unit
Total Package Dissipation ⁽¹⁾ $T_A = 25^\circ\text{C}$	P_D	150	mW
Thermal Resistance Junction to Ambient	$R_{\theta JA}$	833	$^\circ\text{C/W}$
Junction and Storage Temperature Range	T_J, T_{stg}	-55 to +150	$^\circ\text{C}$

1. Device mounted on FR4 glass epoxy printed circuit board using the minimum recommended footprint.

ELECTRICAL CHARACTERISTICS ($T_A = 25^\circ\text{C}$ unless otherwise noted)

Characteristic	Symbol	Min	Max	Unit
OFF CHARACTERISTICS				
Collector–Emitter Breakdown Voltage ⁽²⁾	$V_{(BR)CEO}$			Vdc
($I_C = 1.0\text{ mAdc}$, $I_B = 0$) (NPN)		40	–	
($I_C = -1.0\text{ mAdc}$, $I_B = 0$) (PNP)		-40	–	
Collector–Base Breakdown Voltage	$V_{(BR)CBO}$			Vdc
($I_C = 10\ \mu\text{Adc}$, $I_E = 0$) (NPN)		60	–	
($I_C = -10\ \mu\text{Adc}$, $I_E = 0$) (PNP)		-40	–	
Emitter–Base Breakdown Voltage	$V_{(BR)EBO}$			Vdc
($I_E = 10\ \mu\text{Adc}$, $I_C = 0$) (NPN)		6.0	–	
($I_E = -10\ \mu\text{Adc}$, $I_C = 0$) (PNP)		-5.0	–	
Base Cutoff Current	I_{BL}			nAdc
($V_{CE} = 30\text{ Vdc}$, $V_{EB} = 3.0\text{ Vdc}$) (NPN)		–	50	
($V_{CE} = -30\text{ Vdc}$, $V_{EB} = -3.0\text{ Vdc}$) (PNP)		–	-50	
Collector Cutoff Current	I_{CEX}			nAdc
($V_{CE} = 30\text{ Vdc}$, $V_{EB} = 3.0\text{ Vdc}$) (NPN)		–	50	
($V_{CE} = -30\text{ Vdc}$, $V_{EB} = -3.0\text{ Vdc}$) (PNP)		–	-50	
ON CHARACTERISTICS (2)				
DC Current Gain	h_{FE}			–
($I_C = 0.1\text{ mAdc}$, $V_{CE} = 1.0\text{ Vdc}$) (NPN)		40	–	
($I_C = 1.0\text{ mAdc}$, $V_{CE} = 1.0\text{ Vdc}$)		70	–	
($I_C = 10\text{ mAdc}$, $V_{CE} = 1.0\text{ Vdc}$)		100	300	
($I_C = 50\text{ mAdc}$, $V_{CE} = 1.0\text{ Vdc}$)		60	–	
($I_C = 100\text{ mAdc}$, $V_{CE} = 1.0\text{ Vdc}$)		30	–	
($I_C = -0.1\text{ mAdc}$, $V_{CE} = -1.0\text{ Vdc}$) (PNP)		60	–	
($I_C = -1.0\text{ mAdc}$, $V_{CE} = -1.0\text{ Vdc}$)		80	–	
($I_C = -10\text{ mAdc}$, $V_{CE} = -1.0\text{ Vdc}$)		100	300	
($I_C = -50\text{ mAdc}$, $V_{CE} = -1.0\text{ Vdc}$)		60	–	
($I_C = -100\text{ mAdc}$, $V_{CE} = -1.0\text{ Vdc}$)		30	–	
Collector–Emitter Saturation Voltage	$V_{CE(sat)}$			Vdc
($I_C = 10\text{ mAdc}$, $I_B = 1.0\text{ mAdc}$) (NPN)		–	0.2	
($I_C = 50\text{ mAdc}$, $I_B = 5.0\text{ mAdc}$)		–	0.3	
($I_C = -10\text{ mAdc}$, $I_B = -1.0\text{ mAdc}$) (PNP)		–	-0.25	
($I_C = -50\text{ mAdc}$, $I_B = -5.0\text{ mAdc}$)		–	-0.4	
Base–Emitter Saturation Voltage	$V_{BE(sat)}$			Vdc
($I_C = 10\text{ mAdc}$, $I_B = 1.0\text{ mAdc}$) (NPN)		0.65	0.85	
($I_C = 50\text{ mAdc}$, $I_B = 5.0\text{ mAdc}$)		–	0.95	
($I_C = -10\text{ mAdc}$, $I_B = -1.0\text{ mAdc}$) (PNP)		-0.65	-0.85	
($I_C = -50\text{ mAdc}$, $I_B = -5.0\text{ mAdc}$)		–	-0.95	

2. Pulse Test: Pulse Width $\leq 300\ \mu\text{s}$; Duty Cycle $\leq 2.0\%$.



FFB3946D

ELECTRICAL CHARACTERISTICS (T_A=25°C unless otherwise noted)

Characteristic		Symbol	Min	Max	Unit
SMALL-SIGNAL CHARACTERISTICS					
Current-Gain – Bandwidth Product (I _C = 10 mAdc, V _{CE} = 20 Vdc, f = 100 MHz) (NPN) (I _C = -10 mAdc, V _{CE} = -20 Vdc, f = 100 MHz) (PNP)		f _T	300 250	– –	MHz
Output Capacitance (V _{CB} = 5.0 Vdc, I _E = 0, f = 1.0 MHz) (NPN) (V _{CB} = -5.0 Vdc, I _E = 0, f = 1.0 MHz) (PNP)		C _{obo}	– –	4.0 4.5	pF
Input Capacitance (V _{EB} = 0.5 Vdc, I _C = 0, f = 1.0 MHz) (NPN) (V _{EB} = -0.5 Vdc, I _C = 0, f = 1.0 MHz) (PNP)		C _{ibo}	– –	8.0 10.0	pF
Input Impedance (V _{CE} = 10 Vdc, I _C = 1.0 mAdc, f = 1.0 kHz) (NPN) (V _{CE} = -10 Vdc, I _C = -1.0 mAdc, f = 1.0 kHz) (PNP)		h _{ie}	1.0 2.0	10 12	kΩ
Voltage Feedback Ratio (V _{CE} = 10 Vdc, I _C = 1.0 mAdc, f = 1.0 kHz) (NPN) (V _{CE} = -10 Vdc, I _C = -1.0 mAdc, f = 1.0 kHz) (PNP)		h _{re}	0.5 0.1	8.0 10	X10
Small-Signal Current Gain (V _{CE} = 10 Vdc, I _C = 1.0 mAdc, f = 1.0 kHz) (NPN) (V _{CE} = -10 Vdc, I _C = -1.0 mAdc, f = 1.0 kHz) (PNP)		h _{FE}	100 100	400 400	–
Output Admittance (V _{CE} = 10 Vdc, I _C = 1.0 mAdc, f = 1.0 kHz) (NPN) (V _{CE} = -10 Vdc, I _C = -1.0 mAdc, f = 1.0 kHz) (PNP)		h _{oe}	1.0 3.0	40 60	μmhos
Noise Figure (V _{CE} = 5.0 Vdc, I _C = 100 μAdc, R _S = 1.0 kΩ, f = 1.0 kHz) (NPN) (V _{CE} = -5.0 Vdc, I _C = -100 μAdc, R _S = 1.0 kΩ, f = 1.0 kHz) (PNP)		NF	– –	5.0 4.0	dB
SWITCHING CHARACTERISTICS					
Delay Time	(V _{CC} = 3.0 Vdc, V _{BE} = -0.5 Vdc) (NPN)	t _d	–	35	ns
	(V _{CC} = -3.0 Vdc, V _{BE} = 0.5 Vdc) (PNP)		–	35	
Rise Time	(I _C = 10 mAdc, I _{B1} = 1.0 mAdc) (NPN)	t _r	–	35	
	(I _C = -10 mAdc, I _{B1} = -1.0 mAdc) (PNP)		–	35	
Storage Time	(V _{CC} = 3.0 Vdc, I _C = 10 mAdc) (NPN)	t _s	–	200	ns
	(V _{CC} = -3.0 Vdc, I _C = -10 mAdc) (PNP)		–	225	
Fall Time	(I _{B1} = I _{B2} = 1.0 mAdc) (NPN)	t _f	–	50	
	(I _{B1} = I _{B2} = -1.0 mAdc) (PNP)		–	75	

TYPICAL ELECTRICAL CHARACTERISTICS

(NPN)

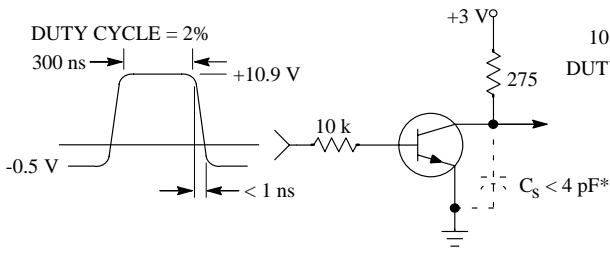

Figure 1. Delay and Rise Time
Equivalent Test Circuit

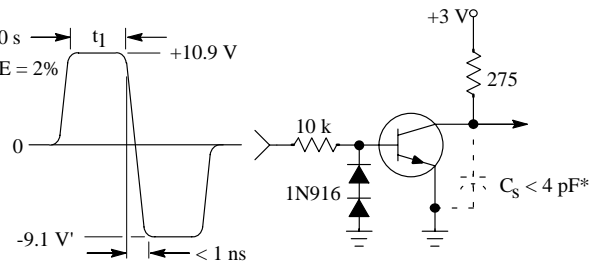

Figure 2. Storage and Fall Time
Equivalent Test Circuit

* Total shunt capacitance of test jig and connectors

TYPICAL TRANSIENT CHARACTERISTICS

— $T_j = 25\text{ C}$
 - - - $T_j = 125\text{ C}$

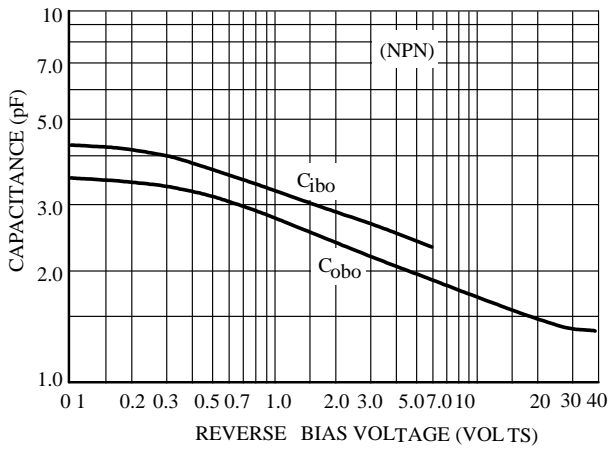

Figure 3. Capacitance

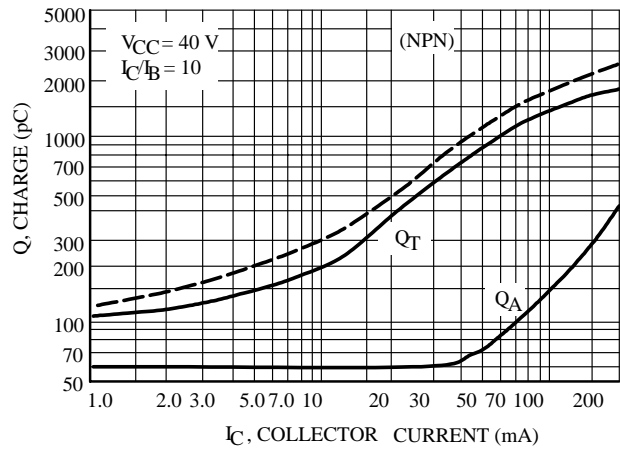

Figure 4. Charge Data

TYPICAL ELECTRICAL CHARACTERISTICS (NPN)

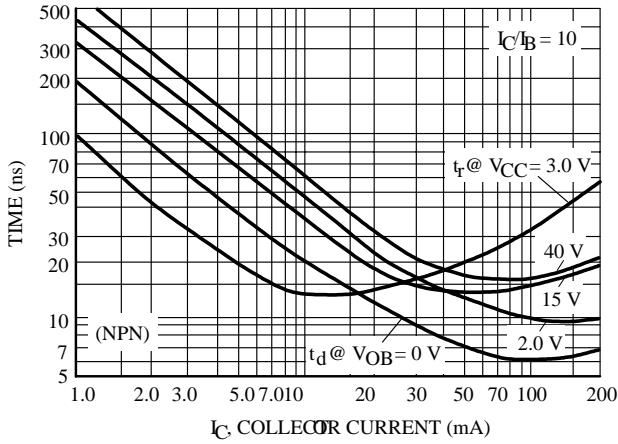

Figure 5. Turn-On Time

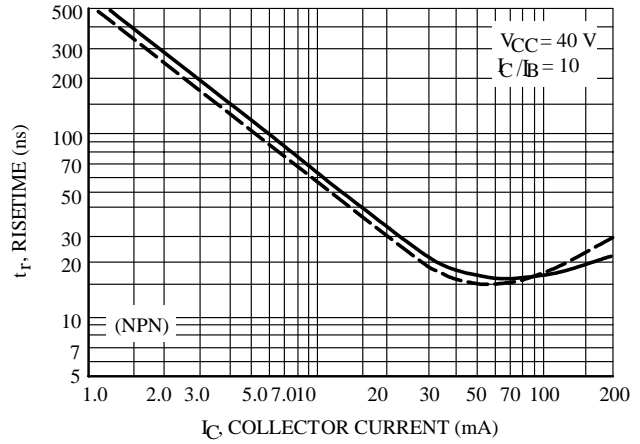

Figure 6. Rise Time

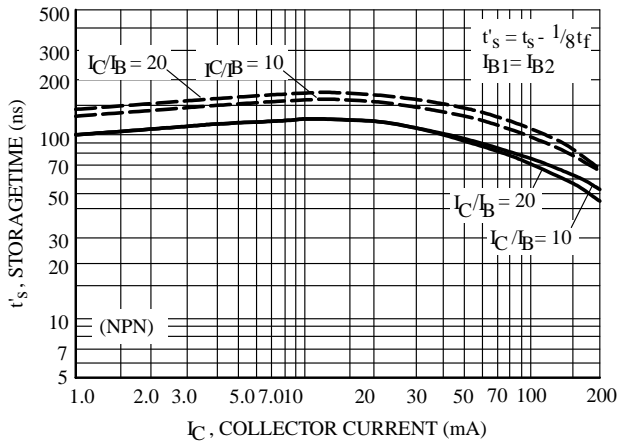

Figure 7. Storage Time

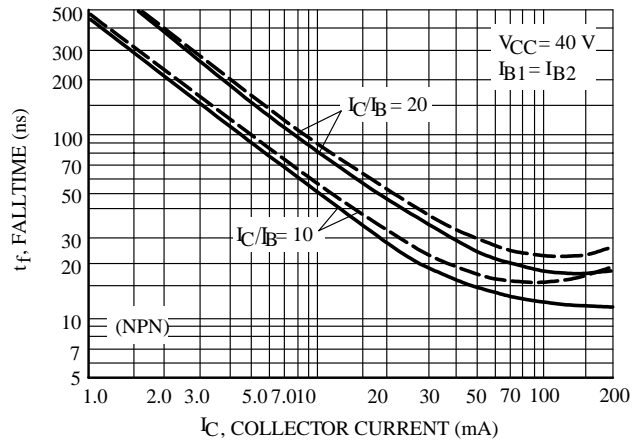

Figure 8. Fall Time

TYPICAL AUDIO SMALL-SIGNAL CHARACTERISTICS NOISE FIGURE VARIATIONS

($V_{CE} = 5.0 \text{ Vdc}$, $T_A = 255^\circ\text{C}$, Bandwidth = 1.0 Hz)

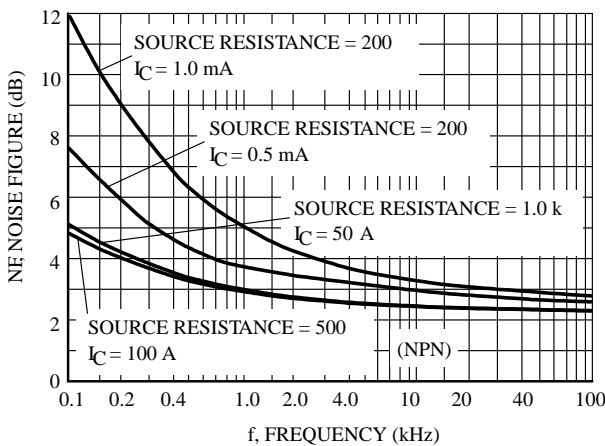

Figure 9. Noise Figure

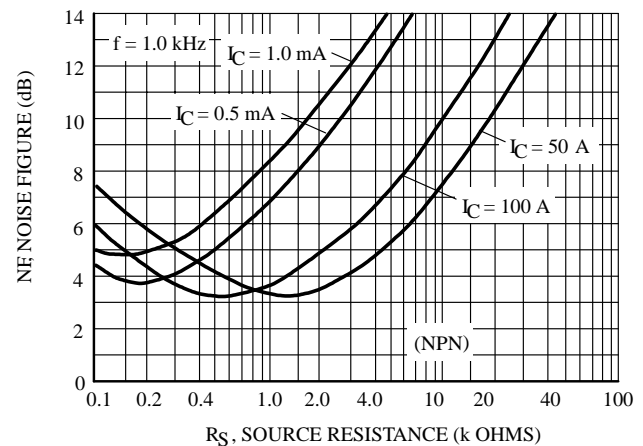

Figure 10. Noise Figure

TYPICAL ELECTRICAL CHARACTERISTICS

(NPN)

h PARAMETERS

($V_{CE} = 10 \text{ Vdc}$, $f = 1.0 \text{ kHz}$, $T_A = 25^\circ\text{C}$)

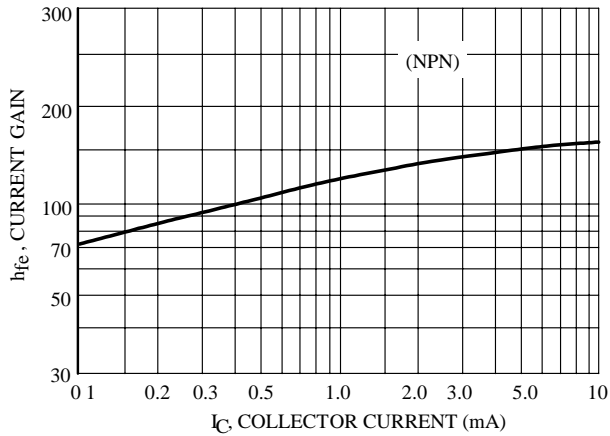

Figure 11. Current Gain

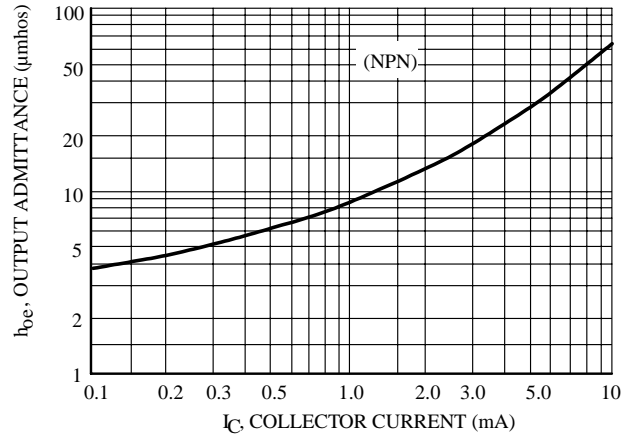

Figure 12. Output Admittance

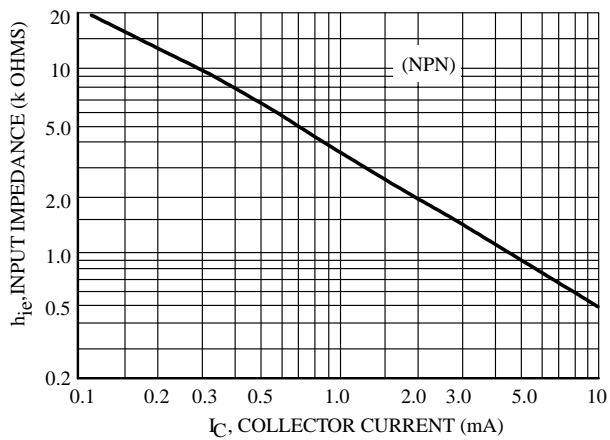

Figure 13. Input Impedance

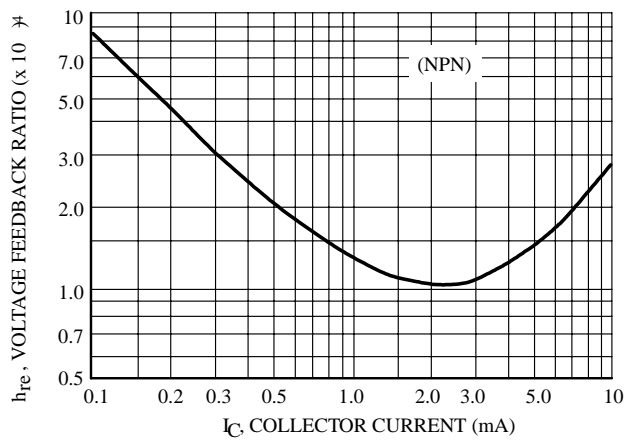

Figure 14. Voltage Feedback Ratio



TYPICAL ELECTRICAL CHARACTERISTICS

(NPN)

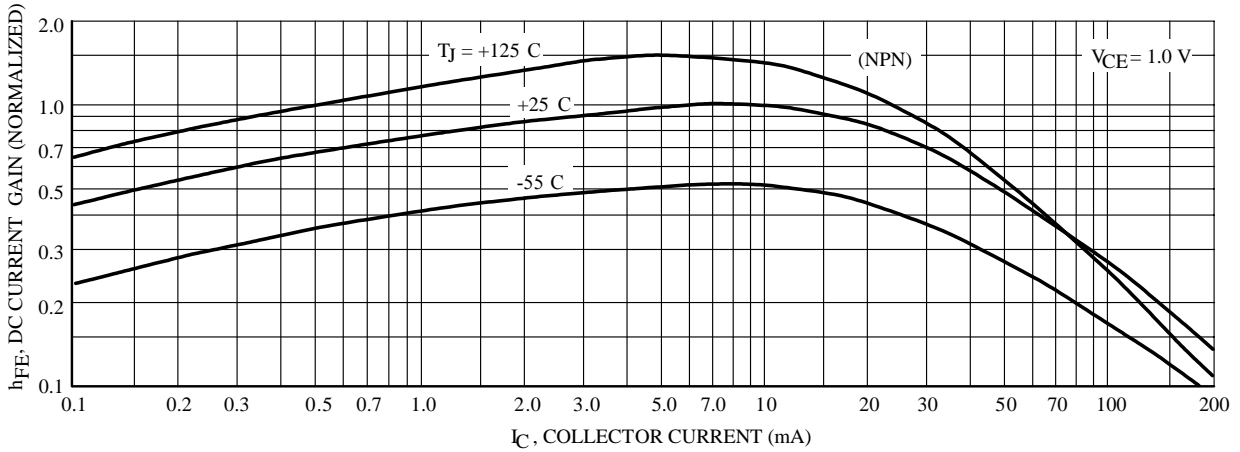

Figure 15. DC Current Gain

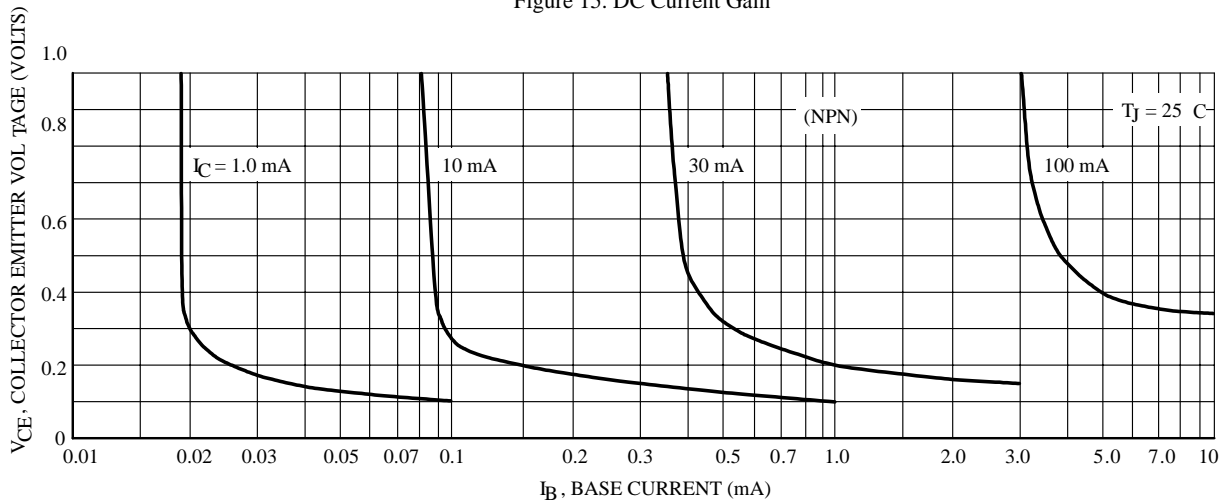

Figure 16. Collector Saturation Region

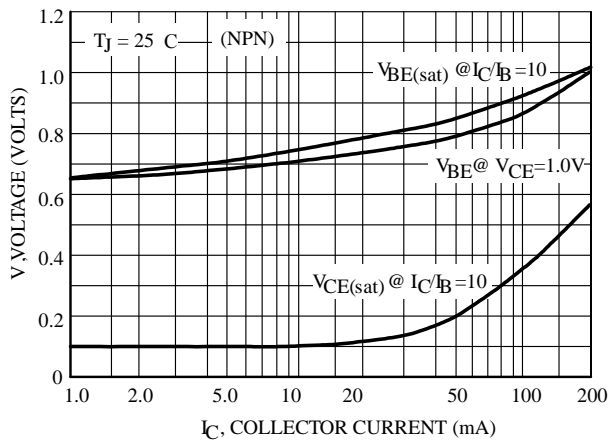

Figure 17. "ON" Voltages

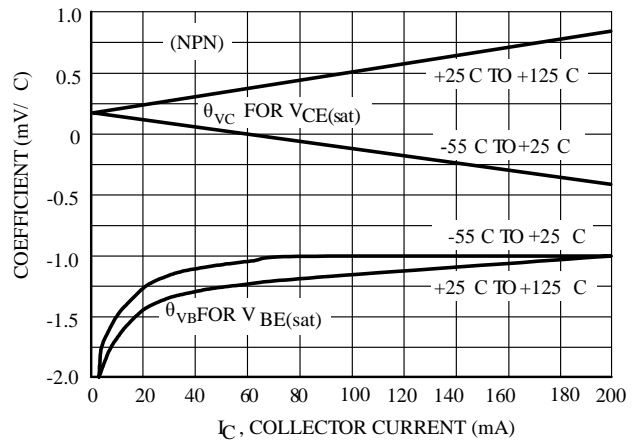

Figure 18. Temperature Coefficients

TYPICAL ELECTRICAL CHARACTERISTICS (PNP)

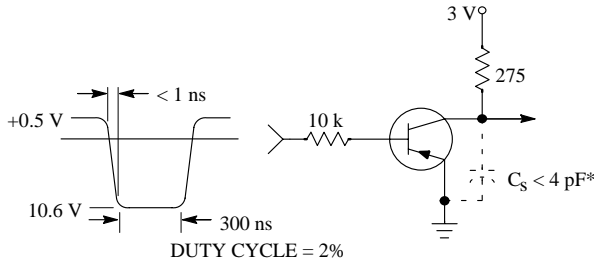

Figure 19. Delay and Rise Time
Equivalent Test Circuit

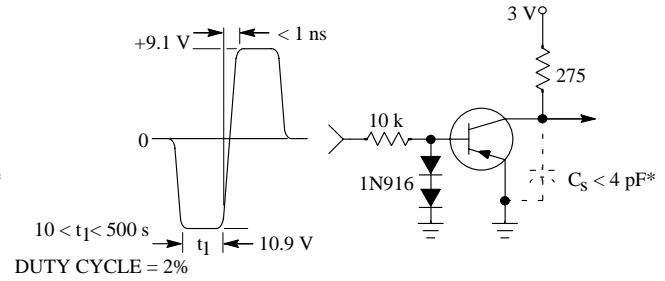

Figure 20. Storage and Fall Time
Equivalent Test Circuit

* Total shunt capacitance of test jig and connectors

TYPICAL TRANSIENT CHARACTERISTICS

— $T_J = 25\text{ C}$
- - - $T_J = 125\text{ C}$

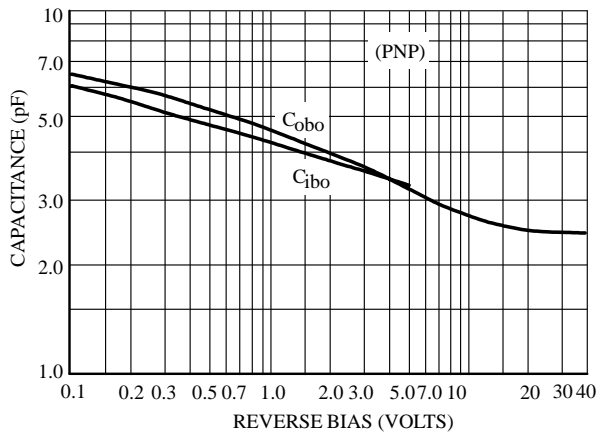

Figure 21. Capacitance

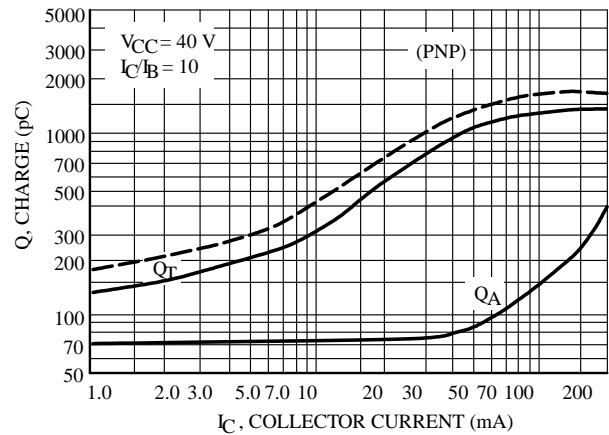

Figure 22. Charge Data

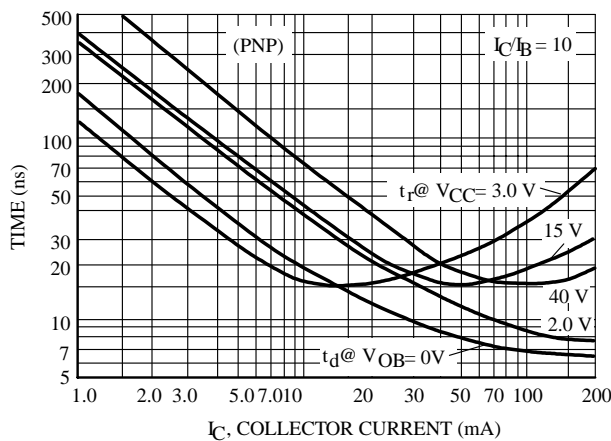

Figure 23. Turn-On Time

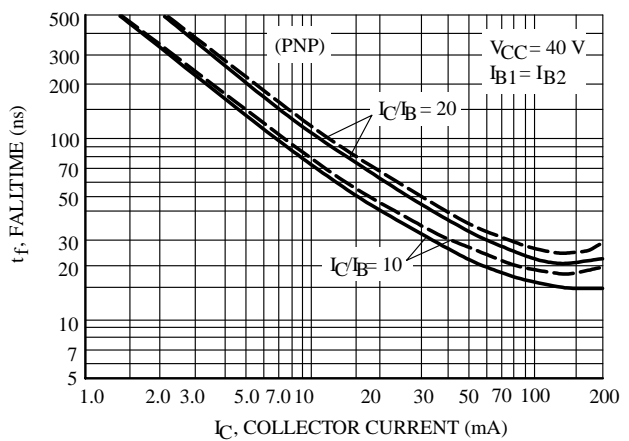

Figure 24. Fall Time



TYPICAL ELECTRICAL CHARACTERISTICS
(PNP)

TYPICAL AUDIO SMALL-SIGNAL CHARACTERISTICS
NOISE FIGURE VARIATIONS

($V_{CE} = \pm 5.0$ Vdc, $T_A = 25^\circ\text{C}$, Bandwidth = 1.0 Hz)

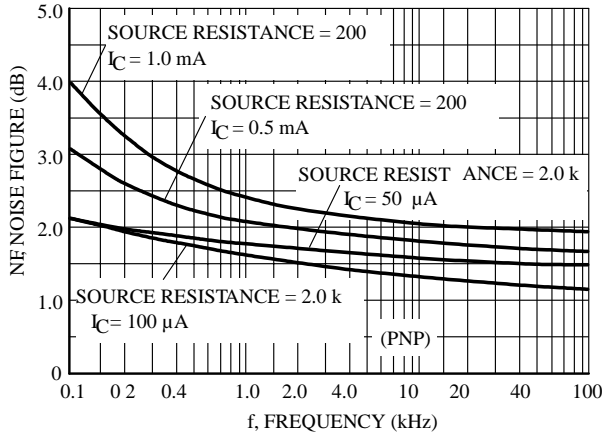

Figure 25.

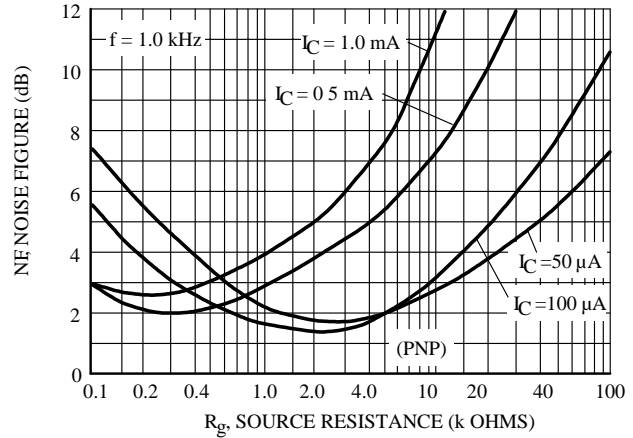

Figure 26.

h PARAMETERS

($V_{CE} = \pm 10$ Vdc, $f = 1.0$ kHz, $T_A = 25^\circ\text{C}$)

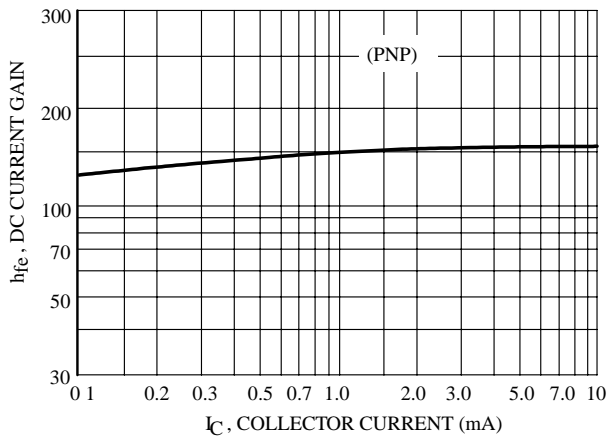

Figure 27. Current Gain

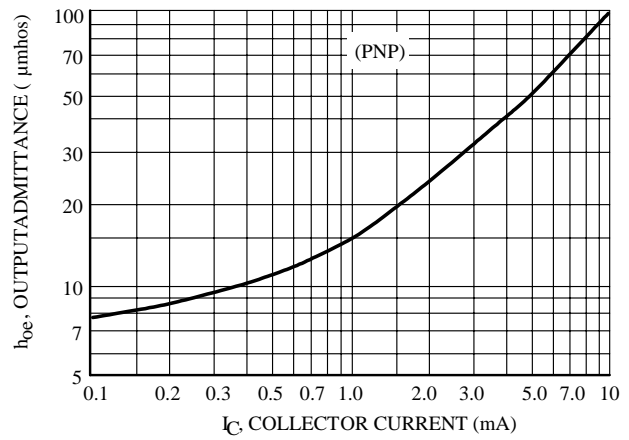

Figure 28. Output Admittance

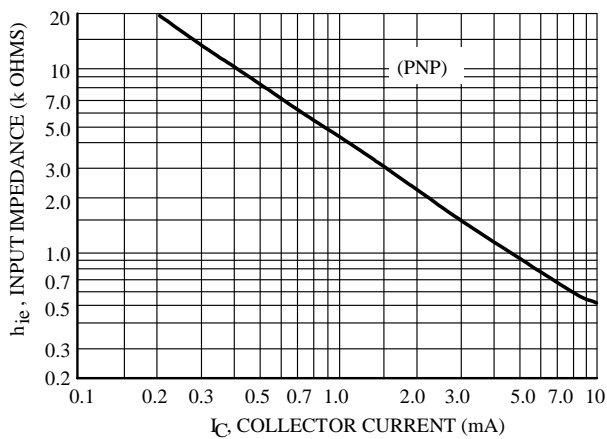

Figure 29. Input Impedance

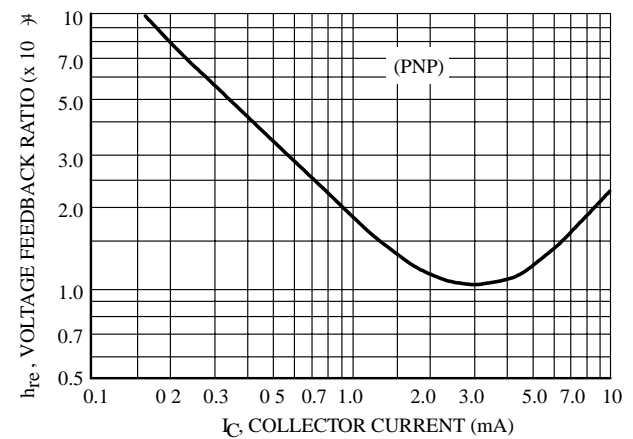

Figure 30. Voltage Feedback Ratio



TYPICAL ELECTRICAL CHARACTERISTICS
(PNP)

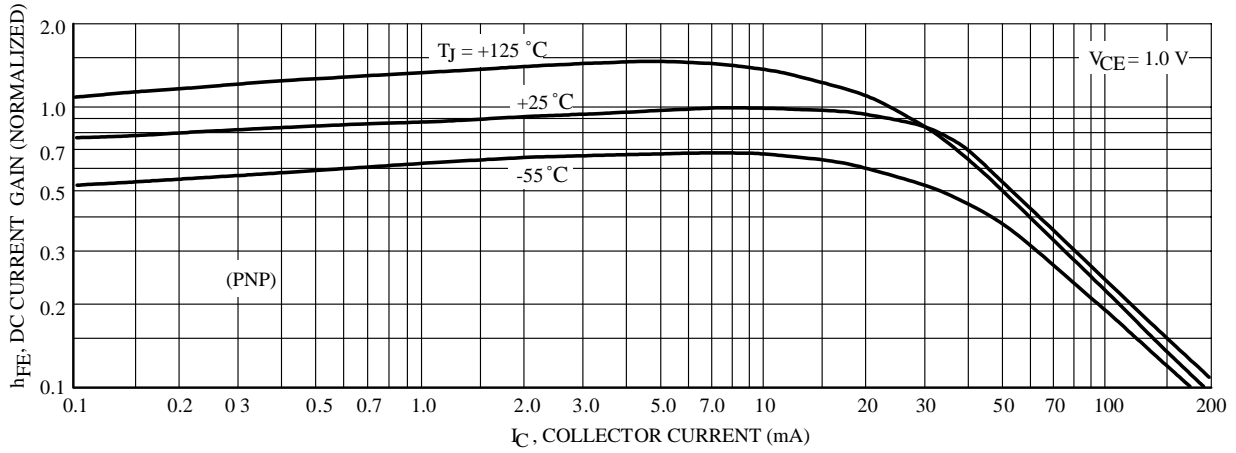

Figure 31. DC Current Gain

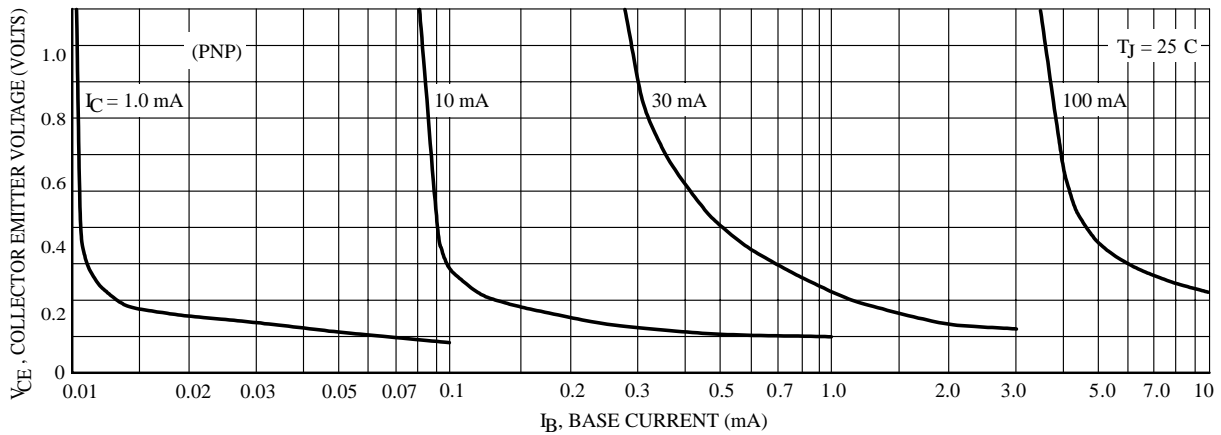

Figure 32. Collector Saturation Region

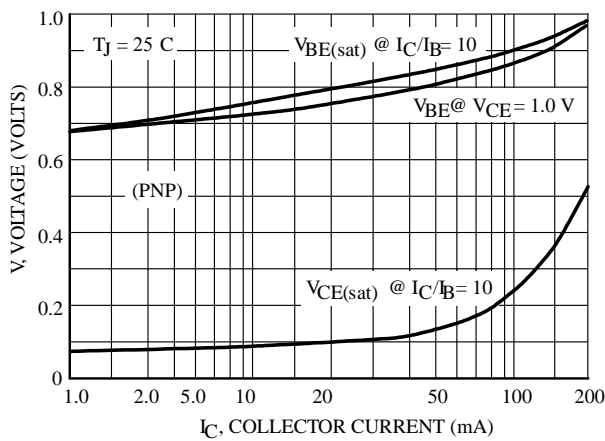

Figure 33. "ON" Voltages

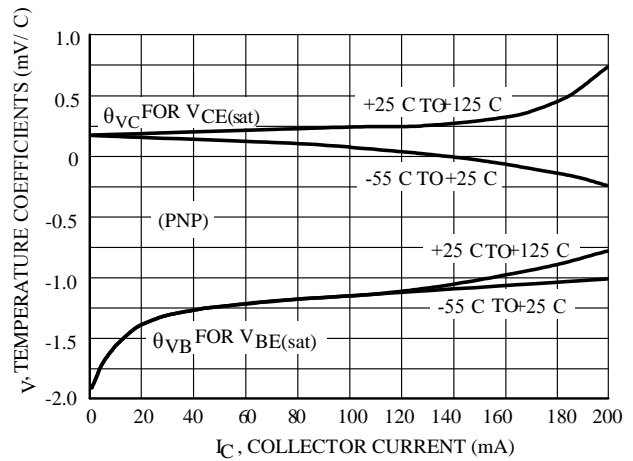
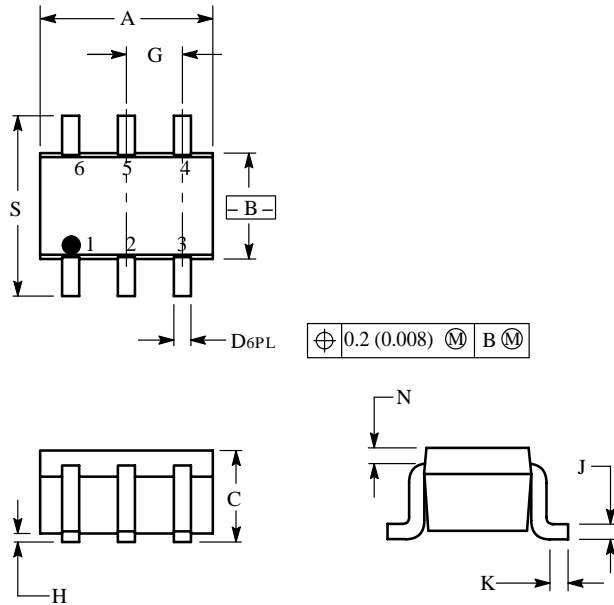

Figure 34. Temperature Coefficients

SC -88/SOT -363

NOTES:

1. DIMENSIONING AND TOLERANCING PER ANSI Y14.5M, 1982.
2. CONTROLLING DIMENSION: INCH.



DIM	INCHES		MILLIMETERS	
	MI	MAX	MIN	MAX
A	0.071	0.087	1.80	2.20
B	0.045	0.053	1.15	1.35
C	0.031	0.043	0.80	1.10
D	0.004	0.012	0.10	0.30
G	0.026 BSC		0.65 BSC	
H	---	0.004	---	0.10
J	0.004	0.010	0.10	0.25
K	0.004	0.012	0.10	0.30
N	0.008 REF		0.20 REF	
S	0.079	0.087	2.00	2.20

- PIN 1 EMITTER 2
- 2 BASE 2
- 3 COLLECTOR 1
- 4 EMITTER 1
- 5 BASE 1
- 6 COLLECTOR 2

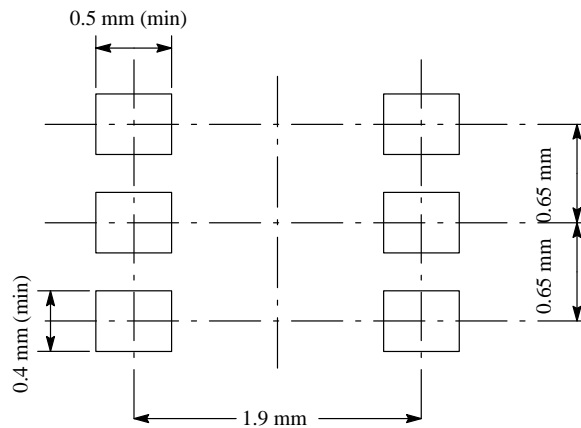

EMBOSSED TAPE AND REEL DATA FOR DISCRETES

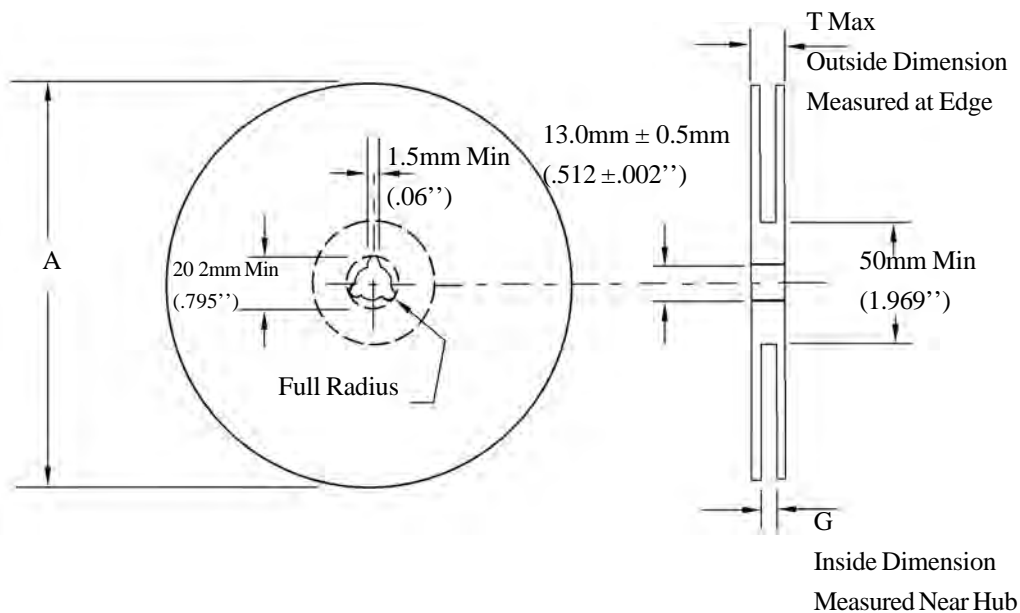

Size	A Max	G	T Max
8 mm	330mm (12.992")	8.4mm+1.5mm, -0.0 (.33"+.059", -0.00)	14.4mm (.56")

Reel Dimensions

Metric Dimensions Govern — English are in parentheses for reference only

Storage Conditions

Temperature: 5 to 40 Deg.C (20 to 30 Deg. C is preferred)

Humidity: 30 to 80 RH (40 to 60 is preferred)

Recommended Period: One year after manufacturing

(This recommended period is for the soldering condition only. The characteristics and reliabilities of the products are not restricted to this limitation)