

## Bias Resistor Transistor

### PNP Silicon Surface Mount Transistor with Monolithic Bias Resistor Network

**• Applications**

Inverter, Interface, Driver

**• Features**

- 1) Built-in bias resistors enable the configuration of an inverter circuit without connecting external input resistors (see equivalent circuit).
- 2) The bias resistors consist of thin-film resistors with complete isolation to allow positive biasing of the input. They also have the advantage of almost completely eliminating parasitic effects.
- 3) Only the on/off conditions need to be set for operation, making the device design easy.

- We declare that the material of product compliance with RoHS requirements.

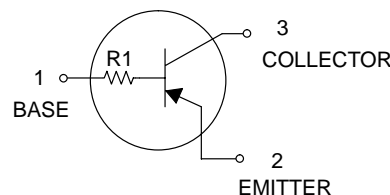
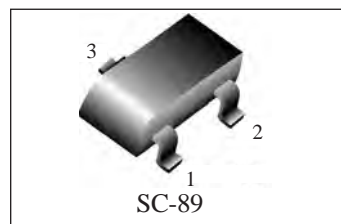

**● Absolute maximum ratings (Ta=25°C)**

Parameter	Symbol	Limits	Unit
Collector-base voltage	V <sub>CB0</sub>	-50	V
Collector-emitter voltage	V <sub>CE0</sub>	-50	V
Emitter-base voltage	V <sub>EB0</sub>	-5	V
Collector current	I <sub>c</sub>	-100	mA
Collector power dissipation	P <sub>c</sub>	200	mW
Junction temperature	T <sub>j</sub>	150	°C
Storage temperature	T <sub>stg</sub>	-55 to +150	°C

**DEVICE MARKING AND RESISTOR VALUES**

Device	Marking	R1 (K)	R2 (K)	Shipping
DTA611T1G	O5	10	-	3000/Tape & Reel
DTA611T3G	O5	10	-	10000/Tape & Reel

**● Electrical characteristics (Ta=25°C)**

Parameter	Symbol	Min.	Typ.	Max.	Unit	Conditions
Collector-base breakdown voltage	BV <sub>CB0</sub>	50	—	—	V	I <sub>c</sub> =50μA
Collector-emitter breakdown voltage	BV <sub>CE0</sub>	50	—	—	V	I <sub>c</sub> =1mA
Emitter-base breakdown voltage	BV <sub>EB0</sub>	5	—	—	V	I <sub>E</sub> =50μA
Collector cutoff current	I <sub>CB0</sub>	—	—	0.5	μA	V <sub>CB</sub> =50V
Emitter cutoff current	I <sub>EB0</sub>	—	—	0.5	μA	V <sub>EB</sub> =4V
Collector-emitter saturation voltage	V <sub>CE(sat)</sub>	—	—	0.3	V	I <sub>c</sub> /I <sub>b</sub> =10mA/1mA
DC current transfer ratio	h <sub>FE</sub>	100	250	600	—	V <sub>CE</sub> =5V, I <sub>c</sub> =1mA
Input resistance	R <sub>1</sub>	7	10	13	kΩ	—
Transition frequency	f <sub>T</sub> □	—	250	—	MHz	V <sub>CE</sub> =10V, I <sub>E</sub> =-5mA, f=100MHz

□ Characteristics of built-in transistor

## ●Electrical characteristic curves

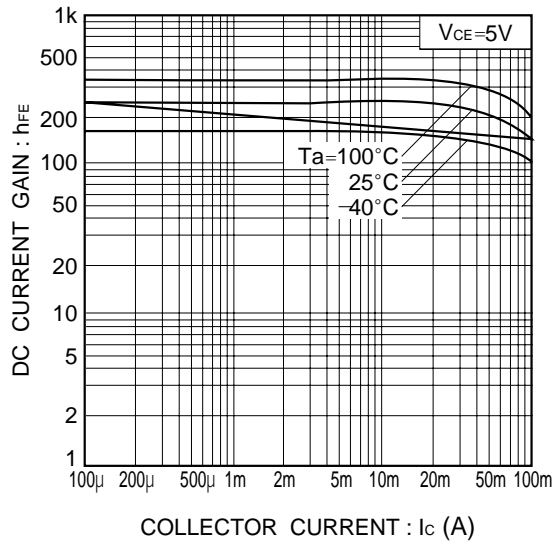

Fig.1 DC current gain vs. collector current

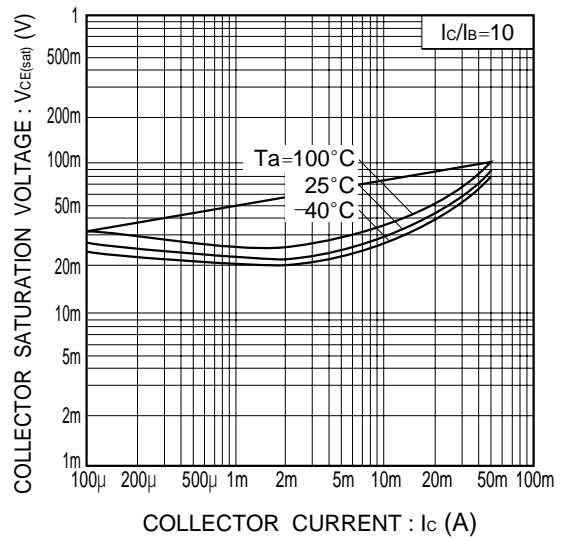
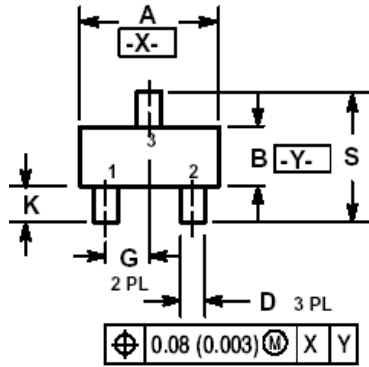

Fig.2 Collector-emitter saturation voltage vs. collector current

## SC-89



**NOTES:**

1. DIMENSIONING AND TOLERANCING PER ANSI Y14.5M, 1982.
2. CONTROLLING DIMENSION: MILLIMETERS
3. MAXIMUM LEAD THICKNESS INCLUDES LEAD FINISH THICKNESS. MINIMUM LEAD THICKNESS IS THE MINIMUM THICKNESS OF BASE MATERIAL.
4. 463C- 01 OBSOLETE, NEW STANDARD 463C- 02.

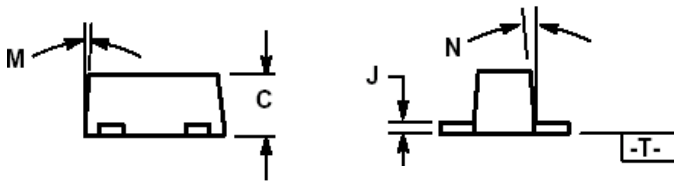

DIM	MILLIMETERS			INCHES		
	MIN	NOM	MAX	MIN	NOM	MAX
A	1.50	1.60	1.70	0.059	0.063	0.067
B	0.75	0.85	0.95	0.030	0.034	0.040
C	0.60	0.70	0.80	0.024	0.028	0.031
D	0.23	0.28	0.33	0.009	0.011	0.013
G	0.50 BSC			0.020 BSC		
H	0.53 REF			0.021 REF		
J	0.10	0.15	0.20	0.004	0.006	0.008
K	0.30	0.40	0.50	0.012	0.016	0.020
L	1.10 REF			0.043 REF		
M	---	---	10 °	---	---	10 °
N	---	---	10 °	---	---	10 °
S	1.50	1.60	1.70	0.059	0.063	0.067

