

Digital transistors

• Features

- 1) Built-in bias resistors enable the configuration of an inverter circuit without connecting external input resistors (see equivalent circuit).
- 2) The bias resistors consist of thinfilm resistors with complete isolation to allow negative biasing of the input. They also have the advantage of almost completely eliminating parasitic effects.
- 3) Only the on/off conditions need to be set for operation, making device design easy.

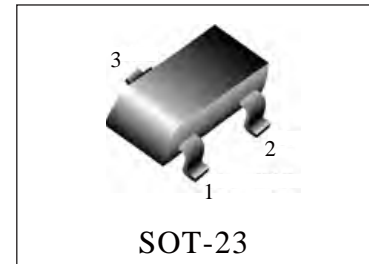

• Device Marking and Ordering Information

Device	Marking	Shipping
DTB202	F14	3000/Tape&Reel
DTB202	F14	10000/Tape&Reel

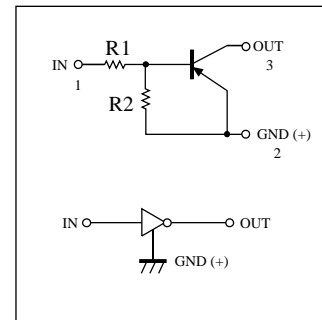

• Absolute maximum ratings ($T_A = 25^\circ\text{C}$)

Parameter	Symbol	Limits	Unit
Supply voltage	V_{CC}	-50	V
Input voltage	V_{IN}	-40~+10	V
Output current	I_C	-500	mA
Power dissipation	P_d	200	mW
Junction temperature	T_j	150	$^\circ\text{C}$
Storage temperature	T_{stg}	-55~+150	$^\circ\text{C}$

• Electrical characteristics ($T_A = 25^\circ\text{C}$)

Parameter	Symbol	Min.	Typ.	Max.	Unit	Conditions
Input voltage	$V_{I(off)}$	-	-	-0.5	V	$V_{CC} = -5V, I_O = 100\mu\text{A}$
	$V_{I(on)}$	-3	-	-		$V_O = -0.3V, I_O = -10\text{mA}$
Output voltage	$V_{O(on)}$	-	-0.1	-0.3	V	$I_O/I_I = -50\text{mA}/-2.5\text{mA}$
Input current	I_I	-	-	-0.88	mA	$V_I = -5V$
Output current	$I_{O(off)}$	-	-	-0.5	μA	$V_{CC} = -50V, V_I = 0V$
DC current gain	G_I	56	-	-	-	$V_O = -5V, I_O = -50\text{mA}$
Input resistance	R1	7	10	13	k Ω	-
Resistance ratio	R2/R1	0.8	1	1.2	-	-
Transition frequency	f_T	-	200	-	MHz	$V_{CE} = -10V, I_E = 5\text{mA}, f = 100\text{MHz}$ *

* Transition frequency of the device

• Electrical characteristic curves

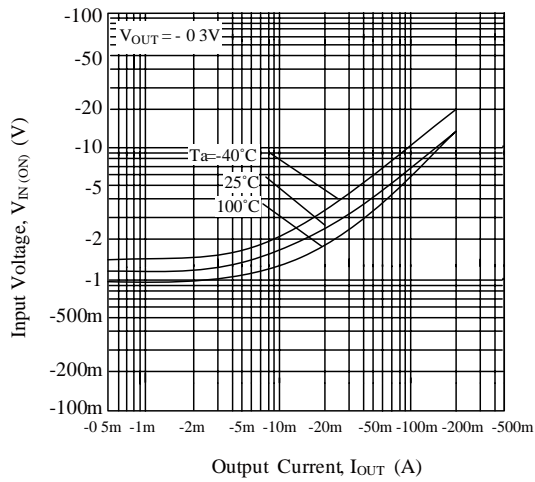

Fig.1 Input Voltage vs. Output Current (ON Characteristics)

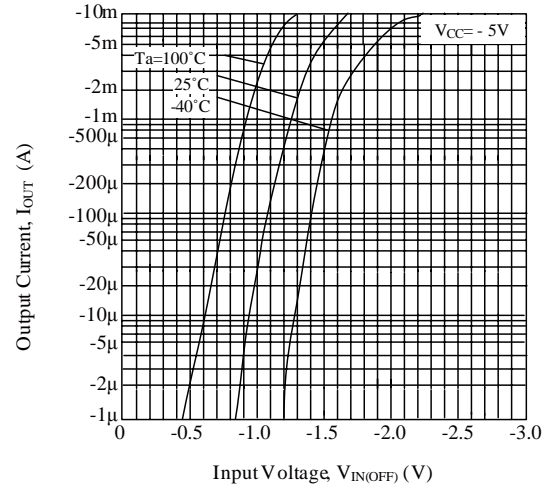

Fig.2 Output Current vs. Input Voltage (OFF Characteristics)

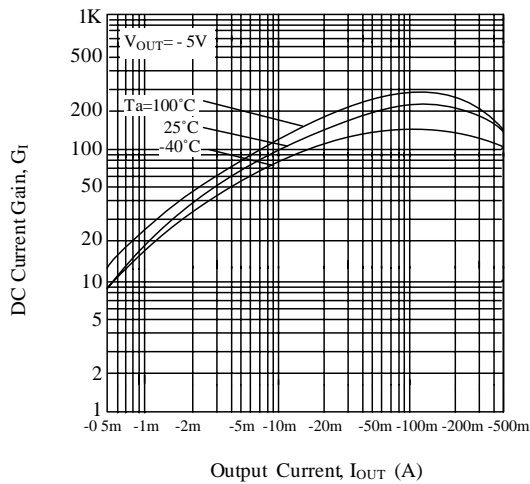

Fig.3 DC Current Gain vs. Output Current

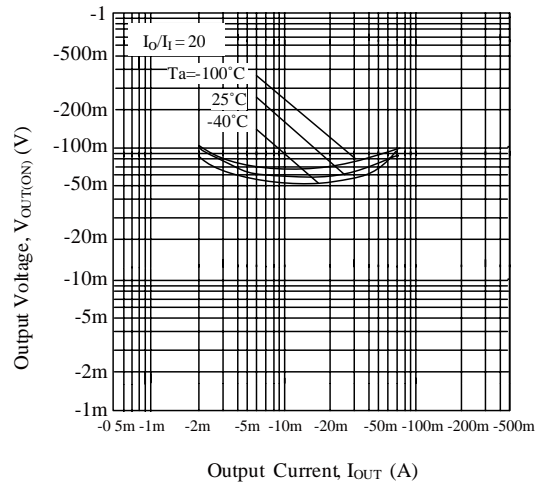
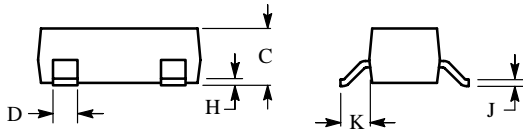
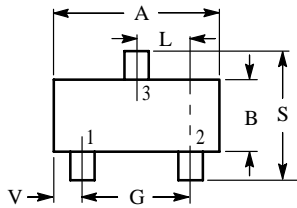

Fig.4 Output Voltage vs. Output Current

SOT-23

NOTES:

1. DIMENSIONING AND TOLERANCING PER ANSI Y14.5M,1982
2. CONTROLLING DIMENSION: INCH.



DIM	INCHES		MILLIMETERS	
	MIN	MAX	MIN	MAX
A	0.1102	0.1197	2.80	3.04
B	0.0472	0.0551	1.20	1.40
C	0.0350	0.0440	0.89	1.11
D	0.0150	0.0200	0.37	0.50
G	0.0701	0.0807	1.78	2.04
H	0.0005	0.0040	0.013	0.100
J	0.0034	0.0070	0.085	0.177
K	0.0140	0.0285	0.35	0.69
L	0.0350	0.0401	0.89	1.02
S	0.0830	0.1039	2.10	2.64
V	0.0177	0.0236	0.45	0.60

PIN 1 BASE
 2 EMITTER
 3 COLLECTOR

