

## Bias Resistor Transistor

### PNP Silicon Surface Mount Transistor with Monolithic Bias Resistor Network

• **Applications**

Inverter, Interface, Driver

• **Features**

- 1) Built-in bias resistors enable the configuration of an inverter circuit without connecting external input resistors (see equivalent circuit).
- 2) The bias resistors consist of thin-film resistors with complete isolation to allow positive biasing of the input. They also have the advantage of almost completely eliminating parasitic effects.
- 3) Only the on/off conditions need to be set for operation, making the device design easy.

- We declare that the material of product compliance with RoHS requirements.



SOT-23

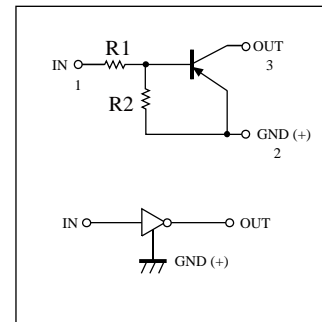

● **Absolute maximum ratings** (Ta=25°C)

| Parameter            | Symbol           | Limits      | Unit |
|----------------------|------------------|-------------|------|
| Supply voltage       | V <sub>CC</sub>  | -50         | V    |
| Input voltage        | V <sub>IN</sub>  | -10 to +5   | V    |
| Output current       | I <sub>c</sub>   | -500        | mA   |
| Power dissipation    | P <sub>D</sub>   | 200         | mW   |
| Junction temperature | T <sub>j</sub>   | 150         | °C   |
| Storage temperature  | T <sub>stg</sub> | -55 to +150 | °C   |

**DEVICE MARKING AND RESISTOR VALUES**

| Device | Marking | R1 (K) | R2 (K) | Shipping         |
|--------|---------|--------|--------|------------------|
| DTB216 | K8      | 1      | 10     | 3000/Tape & Reel |

● **Electrical characteristics** (Ta=25°C)

| Parameter            | Symbol                         | Min. | Typ. | Max. | Unit | Conditions                                               |
|----------------------|--------------------------------|------|------|------|------|----------------------------------------------------------|
| Input voltage        | V <sub>I(off)</sub>            | -    | -    | -0.3 | V    | V <sub>CC</sub> = -5V, I <sub>o</sub> = -100μA           |
|                      | V <sub>I(on)</sub>             | -3   | -    | -    |      | V <sub>O</sub> = -0.3V, I <sub>o</sub> = -20mA           |
| Output voltage       | V <sub>O(on)</sub>             | -    | -    | -0.3 | V    | I <sub>o</sub> /I <sub>i</sub> = -50mA/-2.5mA            |
| Input current        | I <sub>i</sub>                 | -    | -    | -7.2 | mA   | V <sub>i</sub> = -5V                                     |
| Output current       | I <sub>O(off)</sub>            | -    | -    | -0.5 | μA   | V <sub>CC</sub> = -50V, V <sub>i</sub> =0V               |
| DC current gain      | G <sub>i</sub>                 | 56   | -    | -    | -    | V <sub>O</sub> = -5V, I <sub>o</sub> = -50mA             |
| Input resistance     | R <sub>1</sub>                 | 0.7  | 1    | 1.3  | kΩ   | -                                                        |
| Resistance ratio     | R <sub>2</sub> /R <sub>1</sub> | 8    | 10   | 12   | -    | -                                                        |
| Transition frequency | f <sub>T</sub>                 | -    | 200  | -    | MHz  | V <sub>CE</sub> = -10V, I <sub>E</sub> =50mA, f=100MHz * |

\* Transition frequency of the device

●Electrical characteristic curves

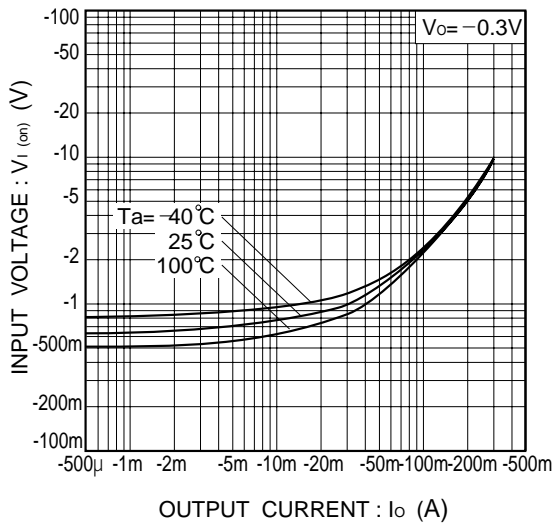

Fig.1 Input voltage vs. output current (ON characteristics)

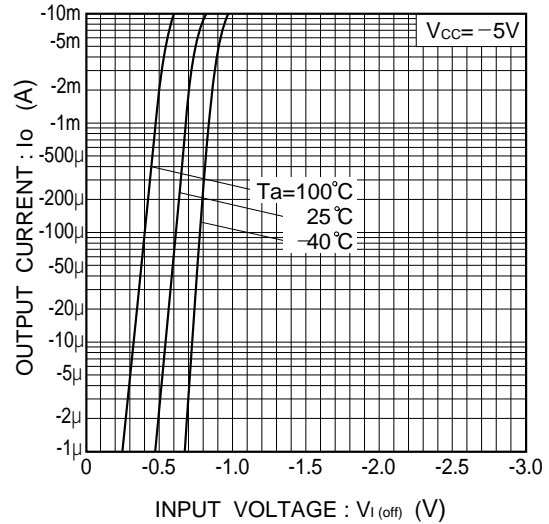

Fig.2 Output current vs. input voltage (OFF characteristics)

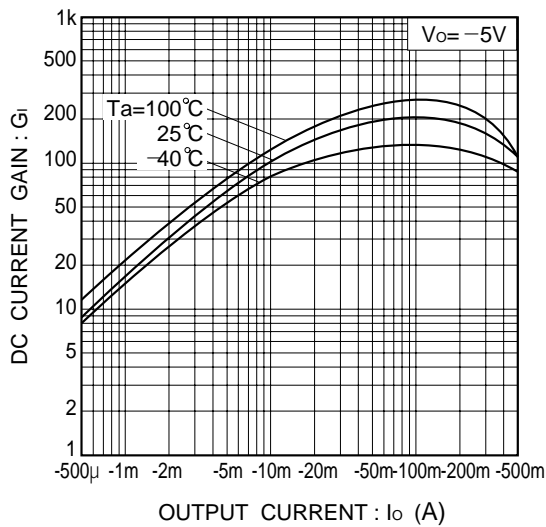

Fig.3 DC current gain vs. output current

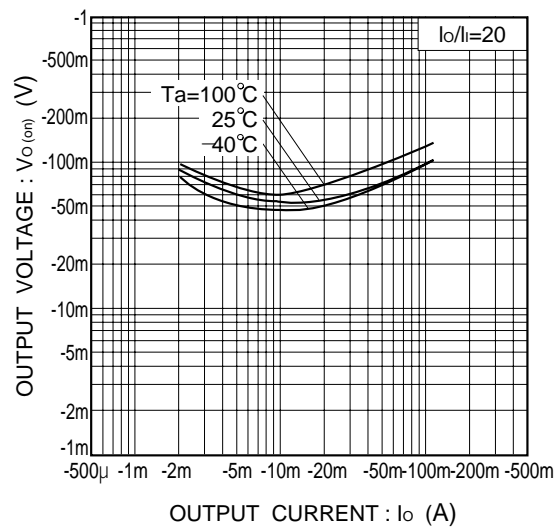
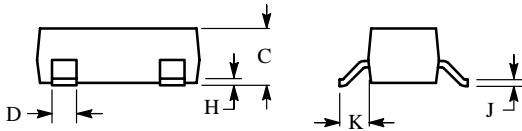
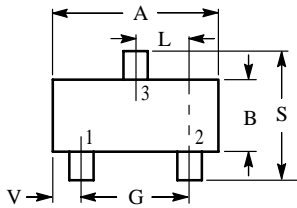

Fig.4 Output voltage vs. output current

## SOT-23

### NOTES:

1. DIMENSIONING AND TOLERANCING PER ANSI Y14.5M,1982
2. CONTROLLING DIMENSION: INCH.



| DIM | INCHES |        | MILLIMETERS |       |
|-----|--------|--------|-------------|-------|
|     | MIN    | MAX    | MIN         | MAX   |
| A   | 0.1102 | 0.1197 | 2.80        | 3.04  |
| B   | 0.0472 | 0.0551 | 1.20        | 1.40  |
| C   | 0.0350 | 0.0440 | 0.89        | 1.11  |
| D   | 0.0150 | 0.0200 | 0.37        | 0.50  |
| G   | 0.0701 | 0.0807 | 1.78        | 2.04  |
| H   | 0.0005 | 0.0040 | 0.013       | 0.100 |
| J   | 0.0034 | 0.0070 | 0.085       | 0.177 |
| K   | 0.0140 | 0.0285 | 0.35        | 0.69  |
| L   | 0.0350 | 0.0401 | 0.89        | 1.02  |
| S   | 0.0830 | 0.1039 | 2.10        | 2.64  |
| V   | 0.0177 | 0.0236 | 0.45        | 0.60  |

PIN 1 BASE  
 2 EMITTER  
 3 COLLECTOR

