

## Dual NPN+PNP Digital transistors (built-in resistors)

### FEATURES

- Two DTC704(NPN)+DTA804(PNP) chip in a package
- Mounting possible with SOT-563 automatic mounting machines
- Transistor elements are independent, eliminating interference
- Mounting cost and area be cut in half

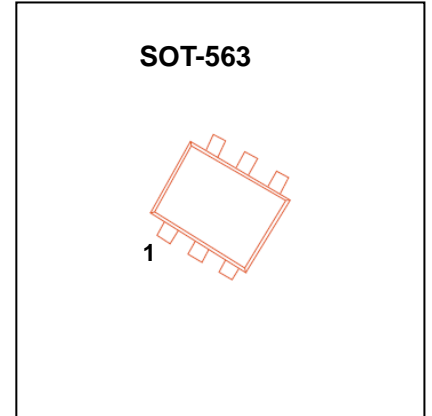

**Marking: D12**

Equivalent circuit

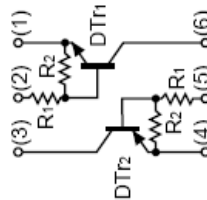

### $T_{R1}$ Absolute maximum ratings ( $T_a=25^{\circ}\text{C}$ )

Parameter	Symbol	Limits	Unit
Supply voltage	$V_{CC}$	50	V
Input voltage	$V_{IN}$	-10~40	V
Output current	$I_O$	100	mA
	$I_{C(MAX)}$	100	
Power dissipation	$P_d$	150	mW
Junction temperature	$T_j$	150	$^{\circ}\text{C}$
Storage temperature	$T_{stg}$	-55~150	$^{\circ}\text{C}$

### $T_{R1}$ Electrical characteristics ( $T_a=25^{\circ}\text{C}$ )

Parameter	Symbol	Min.	Typ	Max.	Unit	Conditions
Input voltage	$V_{I(off)}$	0.5			V	$V_{CC}=5V, I_O=100\mu A$
	$V_{I(on)}$			3		$V_O=0.3V, I_O=2mA$
Output voltage	$V_{O(on)}$		0.1	0.3	V	$I_O/I_I=10mA/0.5mA$
Input current	$I_I$			0.18	mA	$V_I=5V$
Output current	$I_{O(off)}$			0.5	$\mu A$	$V_{CC}=50V, V_I=0$
DC current gain	$G_I$	68				$V_O=5V, I_O=5mA$
Input resistance	$R_1$	32.9	47	61.1	K $\Omega$	-
Resistance ratio	$R_2/R_1$	0.8	1	1.2		-
Transition frequency	$f_T$		250		MHz	$V_{CE}=10V, I_E=5mA, f=100MHz$

## T<sub>R2</sub> Absolute maximum ratings (Ta=25°C)

Parameter	Symbol	Limits	Unit
Supply voltage	V <sub>CC</sub>	-50	V
Input voltage	V <sub>IN</sub>	-40~10	V
Output current	I <sub>o</sub>	-100	mA
	I <sub>C(MAX)</sub>	-100	
Power dissipation	Pd	150	mW
Junction temperature	T <sub>j</sub>	150	°C
Storage temperature	T <sub>stg</sub>	-55~150	°C

## T<sub>R2</sub> Electrical characteristics (Ta=25°C)

Parameter	Symbol	Min.	Typ	Max.	Unit	Conditions
Input voltage	V <sub>I(off)</sub>	-0.5			V	V <sub>CC</sub> =-5V, I <sub>o</sub> =-100μA
	V <sub>I(on)</sub>			-3		V <sub>O</sub> =-0.3V, I <sub>o</sub> =-2mA
Output voltage	V <sub>O(on)</sub>		-0.1	-0.3	V	I <sub>o</sub> /I <sub>i</sub> =-10mA/-0.5mA
Input current	I <sub>i</sub>			-0.18	mA	V <sub>i</sub> =-5V
Output current	I <sub>O(off)</sub>			-0.5	μA	V <sub>CC</sub> =-50V, V <sub>i</sub> =0
DC current gain	G <sub>i</sub>	68				V <sub>O</sub> =-5V, I <sub>o</sub> =-5mA
Input resistance	R <sub>1</sub>	32.9	47	61.1	KΩ	-
Resistance ratio	R <sub>2</sub> /R <sub>1</sub>	0.8	1	1.2		-
Transition frequency	f <sub>T</sub>		250		MHz	V <sub>CE</sub> =-10V, I <sub>E</sub> =-5mA, f=100MHz

## ●Electrical characteristics curves DTr1 (DTC704)

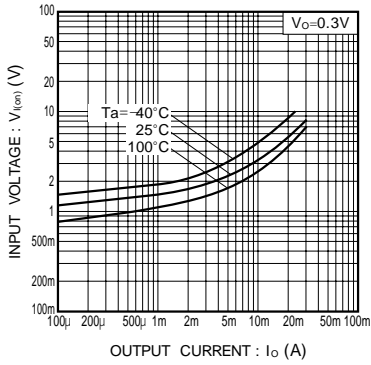

Fig.1 Input voltage vs. output current (ON characteristics)

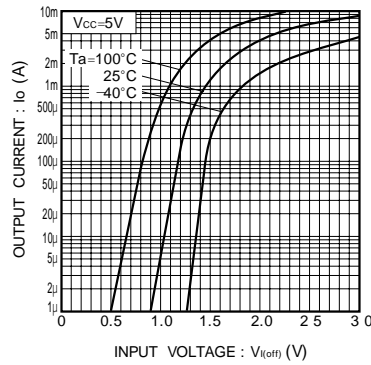

Fig.2 Output current vs. input voltage (OFF characteristics)

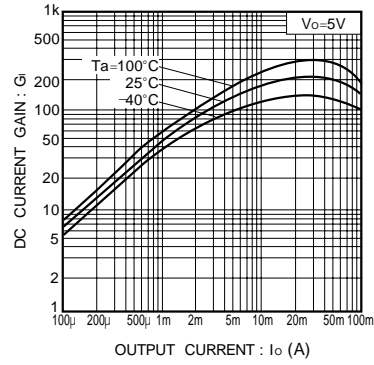

Fig.3 DC current gain vs. output current

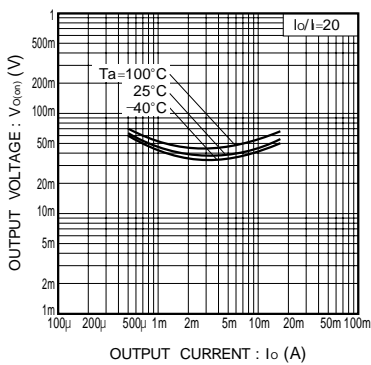

Fig.4 Output voltage vs. output current

## ●Electrical characteristics curves DTr2 (DTA804)

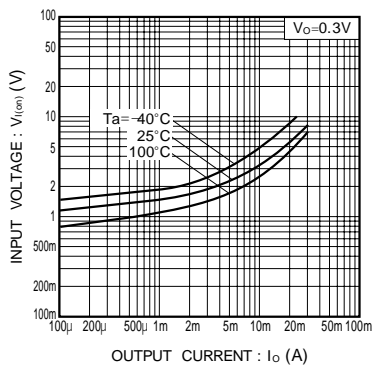

Fig.1 Input voltage vs. output current (ON characteristics)

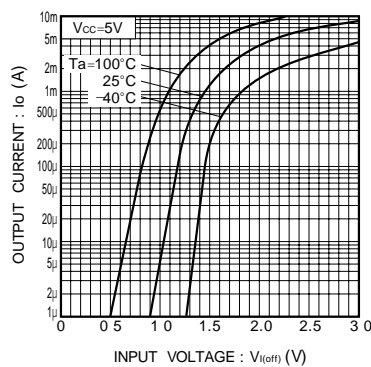

Fig.2 Output current vs. input voltage (OFF characteristics)

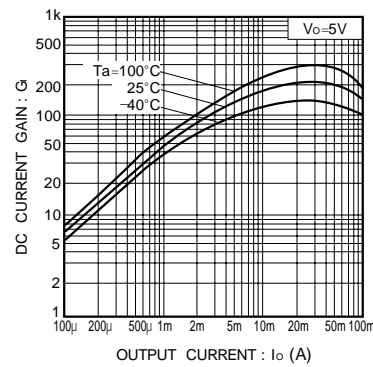

Fig.3 DC current gain vs. output current

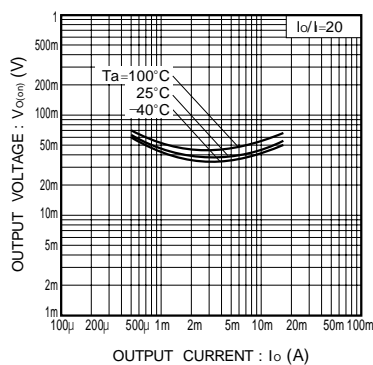
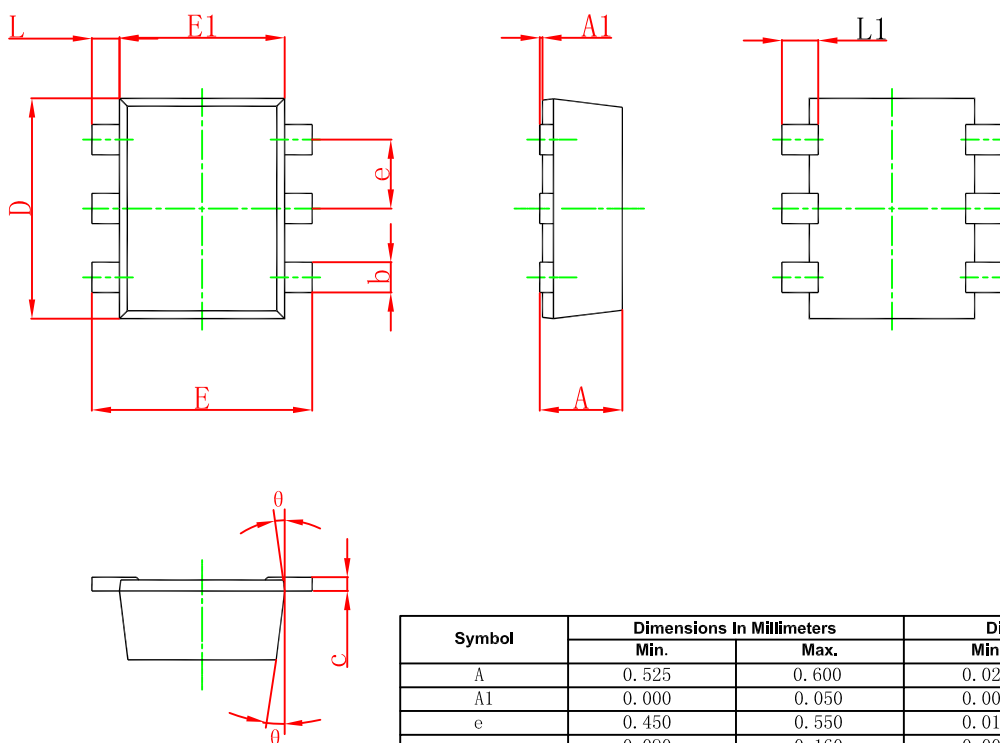

Fig.4 Output voltage vs. output current

## SOT- 563 Package Outline Dimensions



Symbol	Dimensions In Millimeters		Dimensions In Inches	
	Min.	Max.	Min.	Max.
A	0.525	0.600	0.021	0.024
A1	0.000	0.050	0.000	0.002
e	0.450	0.550	0.018	0.022
c	0.090	0.160	0.004	0.006
D	1.500	1.700	0.059	0.067
b	0.170	0.270	0.007	0.011
E1	1.100	1.300	0.043	0.051
E	1.500	1.700	0.059	0.067
L	0.100	0.300	0.004	0.012
L1	0.200	0.400	0.008	0.016
$\theta$	7 °REF.		7 °REF.	

## SOT- 563 Suggested Pad Layout

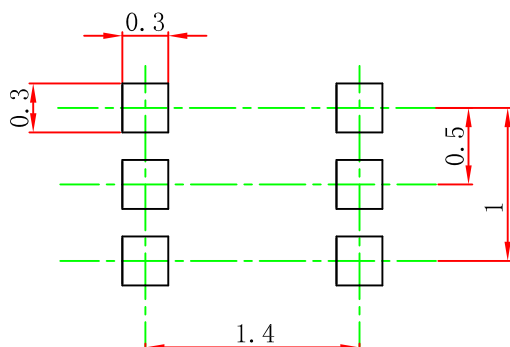

Note:  
 1. Controlling dimension: in millimeters.  
 2. General tolerance:  $\pm 0.05\text{mm}$ .  
 3. The pad layout is for reference purposes only.

## SOT- 563 Tape and Reel

### SOT-563 Embossed Carrier Tape

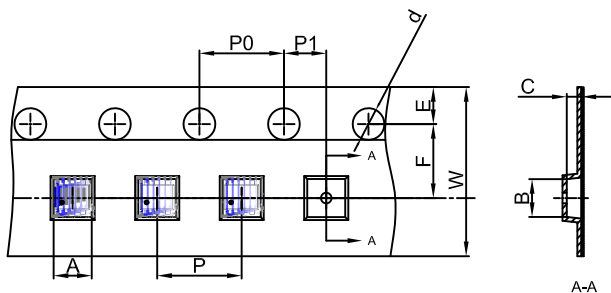

#### Packaging Description:

SOT-563 parts are shipped in tape. The carrier tape is made from a dissipative (carbon filled) polycarbonate resin. The cover tape is a multilayer film (Heat Activated Adhesive in nature) primarily composed of polyester film, adhesive layer, sealant, and anti-static sprayed agent. These reeled parts in standard option are shipped with 3,000 units per 7" or 17.8cm diameter reel. The reels are clear in color and is made of polystyrene plastic (anti-static coated).

Dimensions are in millimeter										
Pkg type	A	B	C	d	E	F	P0	P	P1	W
SOT-563	1.78	1.78	0.69	Ø1.50	1.75	3.50	4.00	4.00	2.00	8.00

### SOT-563 Tape Leader and Trailer

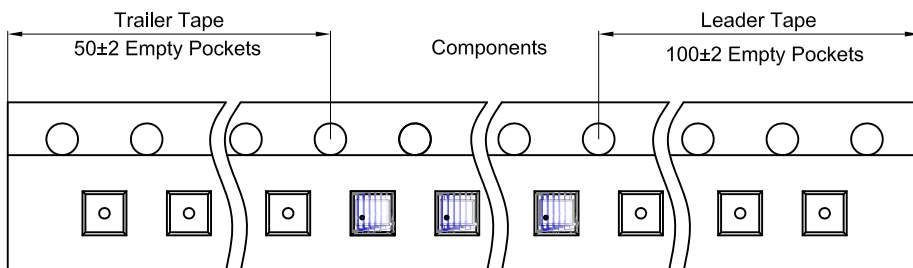

### SOT-563 Reel

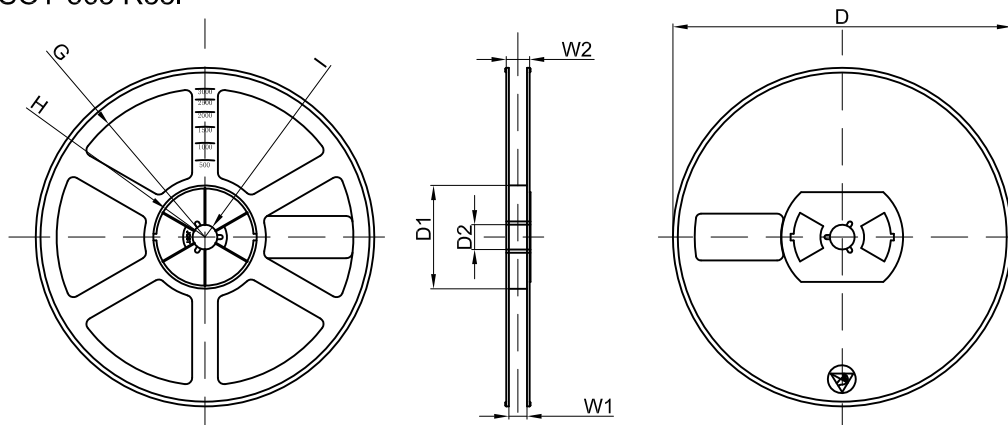

Dimensions are in millimeter								
Reel Option	D	D1	D2	G	H	I	W1	W2
7" Dia	Ø178.00	54.40	13.00	R78.00	R25.60	R6.50	9.50	12.30

REEL	Reel Size	Box	Box Size(mm)	Carton	Carton Size(mm)	G.W.(kg)
3000 pcs	7 inch	45,000 pcs	203×203×195	180,000 pcs	438×438×220	