

N-Channel Power MOSFET

DESCRIPTION

The FTK35N03PDFN33 uses advanced trench technology and design to provide excellent $R_{DS(ON)}$ with low gate charge. It can be used in a wide variety of applications

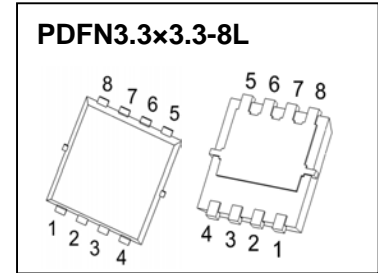

FEATURES

- High density cell design for ultra low $R_{DS(ON)}$
- Fully characterized avalanche voltage and current
- Good stability and uniformity with high E_{AS}
- Excellent package for good heat dissipation
- Special process technology for high ESD capability

APPLICATIONS

- High side switch in POL DC/DC converter
- Secondary side synchronous rectifier

MARKING



35N03 = Part No.
Solid dot=Pin1 indicator
XXX=Date Code

EQUIVALENT CIRCUIT

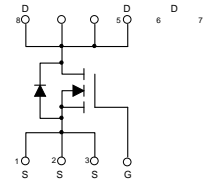

MAXIMUM RATINGS ($T_a=25^\circ\text{C}$ unless otherwise noted)

Parameter	Symbol	Limit	Unit
Drain-Source Voltage	V_{DS}	30	V
Gate-Source Voltage	V_{GS}	± 20	V
Continuous Drain Current	$I_D^{(1)}$	35	A
Pulsed Drain Current	I_{DM}	120	A
Single Pulsed Avalanche Energy	$E_{AS}^{(2)}$	150	mJ
Power Dissipation	P_D	1.5	W
Thermal Resistance from Junction to Ambient	$R_{\theta JA}^{(1)}$	83.3	$^\circ\text{C/W}$
Junction Temperature	T_J	150	$^\circ\text{C}$
Storage Temperature Range	T_{stg}	-55 ~ +150	$^\circ\text{C}$
Lead Temperature for Soldering Purposes(1/8" from case for 10s)	T_L	260	$^\circ\text{C}$

(1).Mounted on a glass epoxy board of 25.4 mm x 25.4 mm x 0.8 mmt

(2). E_{AS} condition: $V_{DD}=15\text{V}$, $L=0.1\text{mH}$, $R_G=25\Omega$, Starting $T_J = 25^\circ\text{C}$



FTK35N03PDFN33

ELECTRICAL CHARACTERISTICS($T_a=25^{\circ}\text{C}$ unless otherwise specified)

Parameter	Symbol	Test Condition	Min	Typ	Max	Unit
Off characteristics						
Drain-source breakdown voltage	$V_{(BR)DSS}$	$V_{GS} = 0V, I_D = 250\mu A$	30			V
Zero gate voltage drain current	I_{DSS}	$V_{DS} = 30V, V_{GS} = 0V$			1	μA
Gate-body leakage current	I_{GSS}	$V_{DS} = 0V, V_{GS} = \pm 20V$			± 100	nA
On characteristics (note1)						
Gate-threshold voltage	$V_{GS(th)}$	$V_{DS} = V_{GS}, I_D = 250\mu A$	1.0	1.6	3.0	V
Static drain-source on-state resistance	$R_{DS(on)}$	$V_{GS} = 4.5V, I_D = 10A$		8.2	9.5	m Ω
		$V_{GS} = 10V, I_D = 12A$		4.8	5.5	m Ω
Forward transconductance	g_{fs}	$V_{DS} = 10V, I_D = 12A$	30			S
Dynamic characteristics (note 2)						
Input capacitance	C_{iss}	$V_{DS} = 15V, V_{GS} = 0V,$ $f = 1MHz$		1265		pF
Output capacitance	C_{oss}			600		
Reverse transfer capacitance	C_{rss}			130		
Switching characteristics (note 2)						
Total gate charge	Q_g	$V_{DS} = 15V, V_{GS} = 10V,$ $I_D = 12A$		19		nC
Gate-source charge	Q_{gs}			2.7		
Gate-drain charge	Q_{gd}			2.5		
Turn-on delay time	$t_{d(on)}$	$V_{DD} = 15V, I_D = 12A,$ $V_{GS} = 10V, R_G = 6\Omega$		18		ns
Turn-on rise time	t_r			10		
Turn-off delay time	$t_{d(off)}$			34		
Turn-off fall time	t_f			10		
Drain-Source Diode Characteristics						
Drain-source diode forward voltage(note1)	V_{SD}	$V_{GS} = 0V, I_S = 12A$		0.85	1.2	V
Continuous drain-source diode forward current(note3)	I_S				35	A
Pulsed drain-source diode forward current	I_{SM}				120	A

Notes:

1. Pulse Test : Pulse Width $\leq 300\mu s$, duty cycle $\leq 2\%$.
2. Guaranteed by design, not subject to production.
3. Surface Mounted on FR4 Board, $t \leq 10$ sec.

TYPICAL CHARACTERISTICS

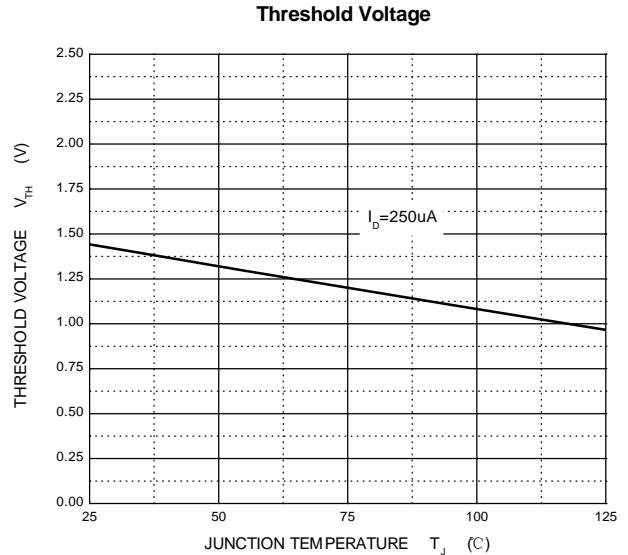
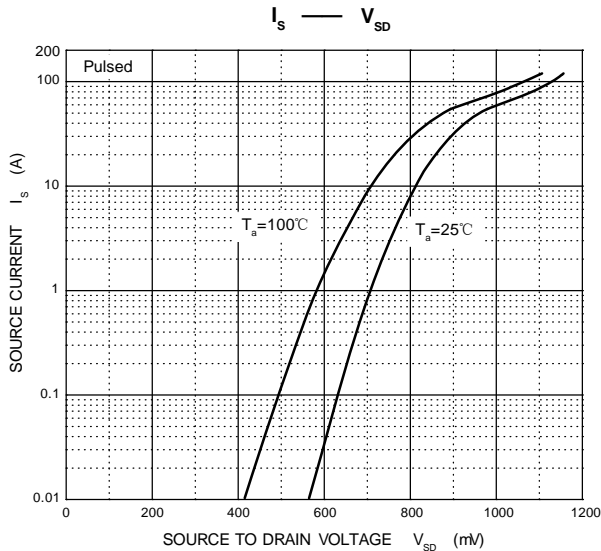
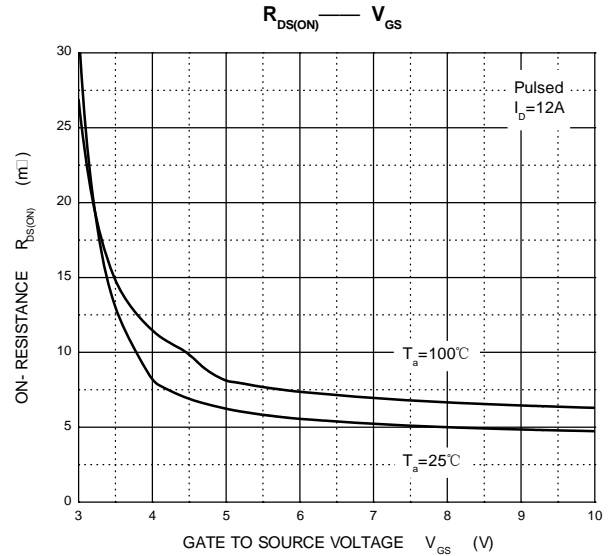
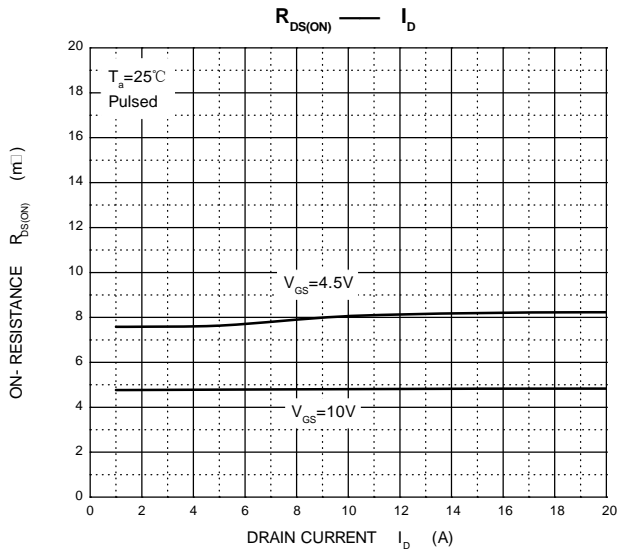
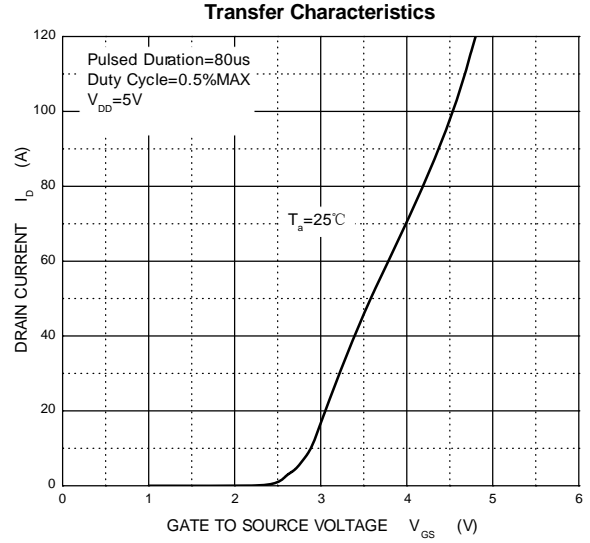
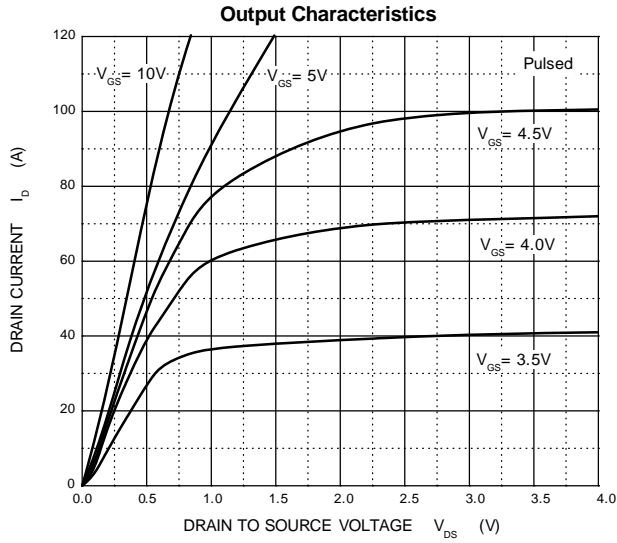

PDFN3.3x3.3-8L-A Package Outline Dimensions

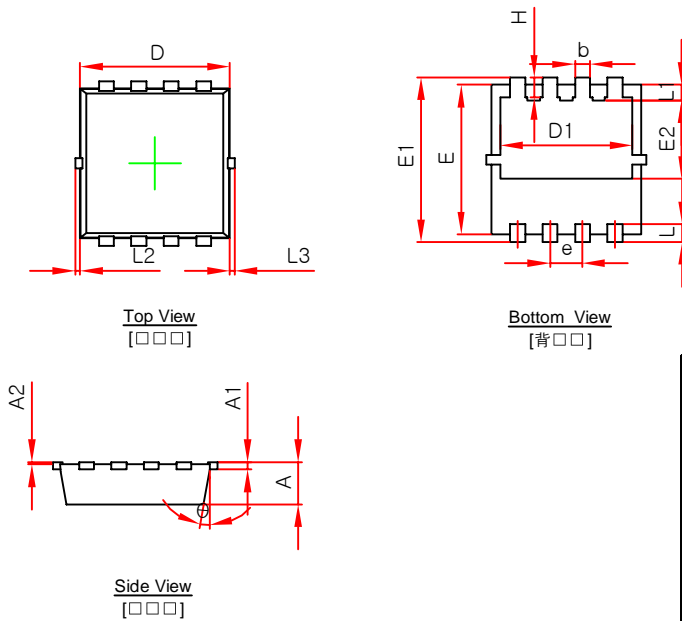

Symbol	Dimensions In Millimeters		Dimensions In Inches	
	Min.	Max.	Min.	Max.
A	0.650	0.850	0.026	0.033
A1	0.152 REF.		0.006 REF.	
A2	0-0.05		0-0.002	
D	2.900	3.100	0.114	0.122
D1	2.540	2.740	0.100	0.108
E	2.900	3.100	0.114	0.122
E1	3.150	3.450	0.124	0.136
E2	1.365	1.765	0.054	0.069
b	0.200	0.400	0.008	0.016
e	0.550	0.750	0.022	0.030
L	0.260	0.460	0.010	0.018
L1	0.165	0.465	0.006	0.018
L2	0-0.100		0-0.004	
L3	0-0.100		0-0.004	
H	0.300	0.500	0.012	0.020
θ	9°	13°	9°	13°

PDFN3.3x3.3-8L-A Suggested Pad Layout

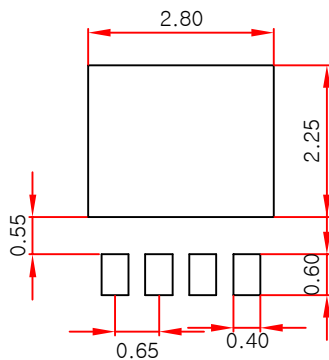

- Note:
1. Controlling dimension: in millimeters.
 2. General tolerance: ± 0.05 mm.
 3. The pad layout is for reference purposes only.

PDFN3.3x3.3-8L-A Package Outline Dimensions

PDFN3.3x3.3-8L-A Tape and reel

PDFN3.3x3.3-8L-A Embossed Carrier Tape

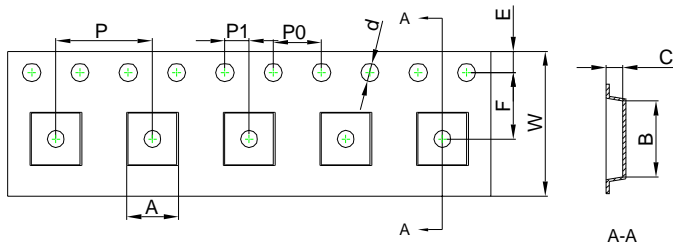

Packaging Description:

PDFN3.3x3.3-8L-A parts are shipped in tape. The carrier tape is made from a dissipative (carbon filled) polycarbonate resin. The cover tape is a multilayer film (Heat Activated Adhesive in nature) primarily composed of polyester film, adhesive layer, sealant, and anti-static sprayed agent. These reeled parts in standard option are shipped with 5,000 units per 13" or 330 cm diameter reel. The reels are clear in color and is made of polystyrene plastic (an i-sta ic coated).

Dimensions are in millimeter										
Pkg type	A	B	C	d	E	F	P0	P	P1	W
PDFN3.3x3.3-8L-A	3.55	3.55	1.10	Ø1.50	1.75	5.50	4.00	8.00	2.00	12.00
(Tolerance)	+/-0.10	+/-0.10	+/-0.10	+0.10/-0.00	+/-0.10	+/-0.05	+/-0.10	+/-0.10	+/-0.05	+0.30/-0.00

PDFN3.3x3.3-8L-A Tape Leader and Trailer

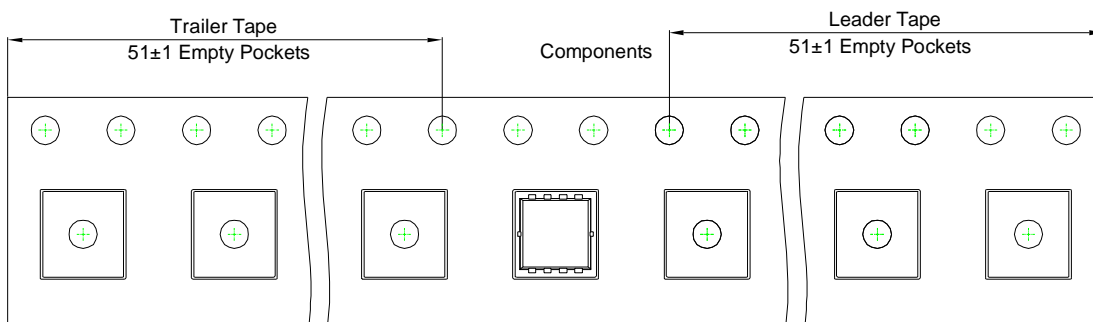

PDFN3.3x3.3-8L-A Reel

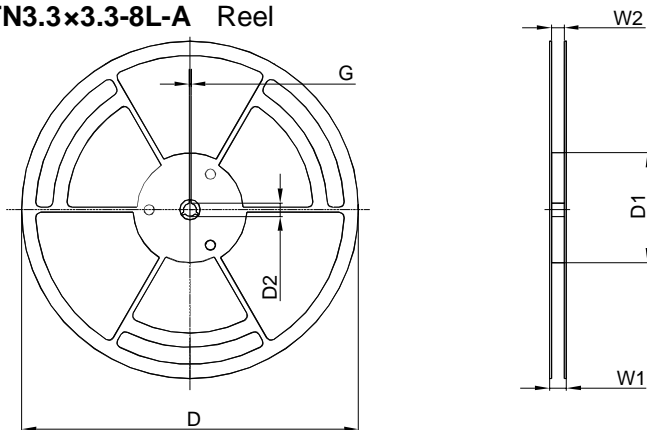

Dimensions are in millimeter						
Reel Option	D	D1	D2	G	W1	W2
13" Dia	Ø330.00	100.00	13.00	1.90	17.60	12.40
Tolerance	+/-1.00	+/-0.50	+/-0.20	+/-0.40	+1.00/-0.00	+1.00/-0.00

REEL	Reel Size	Box	Box Size(mm)	Carton	Carton Size(mm)	G.W.(kg)
5,000 pcs	13 inch	5,000 pcs	336x336x48	40,000 pcs	445x355x365	