

# N-Channel Power MOSFET

## DESCRIPTION

The FTK35N03PDFN56 uses advanced trench technology and design to provide excellent  $R_{DS(ON)}$  with low gate charge. It can be used in a wide variety of applications

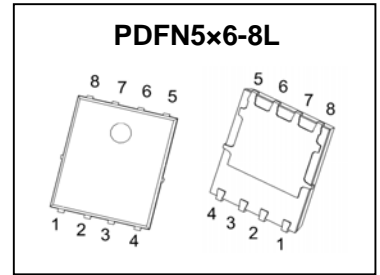

## FEATURES

- High density cell design for ultra low  $R_{DS(ON)}$
- Fully characterized avalanche voltage and current
- Good stability and uniformity with high  $E_{AS}$
- Excellent package for good heat dissipation
- Special process technology for high ESD capability

## APPLICATIONS

- High side switch in POL DC/DC converter
- Secondary side synchronous rectifier

## MARKING



35N03 = Part No.  
Solid dot=Pin1 indicator  
XXX=Date Code

## EQUIVALENT CIRCUIT

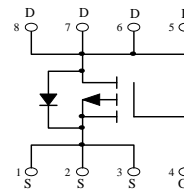

## MAXIMUM RATINGS ( $T_a=25^\circ\text{C}$ unless otherwise noted )

Parameter	Symbol	Limit	Unit
Drain-Source Voltage	$V_{DS}$	30	V
Gate-Source Voltage	$V_{GS}$	$\pm 20$	V
Continuous Drain Current	$I_D^{(1)}$	35	A
Pulsed Drain Current	$I_{DM}$	120	A
Single Pulsed Avalanche Energy	$E_{AS}^{(2)}$	150	mJ
Power Dissipation	$P_D$	2	W
Thermal Resistance from Junction to Ambient	$R_{\theta JA}^{(1)}$	62.5	$^\circ\text{C/W}$
Junction Temperature	$T_J$	150	$^\circ\text{C}$
Storage Temperature Range	$T_{stg}$	-55 ~+150	$^\circ\text{C}$
Lead Temperature for Soldering Purposes(1/8" from case for 10s)	$T_L$	260	$^\circ\text{C}$

(1).Mounted on a glass epoxy board of 25.4 mm x 25.4 mm x 0.8 mmt

(2). $E_{AS}$  condition:  $V_{DD}=15\text{V}$ ,  $L=0.1\text{mH}$ ,  $R_G=25\Omega$ , Starting  $T_J = 25^\circ\text{C}$

**ELECTRICAL CHARACTERISTICS**( $T_a=25^{\circ}\text{C}$  unless otherwise specified)

Parameter	Symbol	Test Condition	Min	Typ	Max	Unit
<b>Off characteristics</b>						
Drain-source breakdown voltage	$V_{(BR)DSS}$	$V_{GS} = 0V, I_D = 250\mu A$	30			V
Zero gate voltage drain current	$I_{DSS}$	$V_{DS} = 30V, V_{GS} = 0V$			1	$\mu A$
Gate-body leakage current	$I_{GSS}$	$V_{DS} = 0V, V_{GS} = \pm 20V$			$\pm 100$	nA
<b>On characteristics (note1)</b>						
Gate-threshold voltage	$V_{GS(th)}$	$V_{DS} = V_{GS}, I_D = 250\mu A$	1.0	1.6	3.0	V
Static drain-source on-state resistance	$R_{DS(on)}$	$V_{GS} = 4.5V, I_D = 10A$		8.2	9.5	m $\Omega$
		$V_{GS} = 10V, I_D = 12A$		5.0	7.0	m $\Omega$
Forward transconductance	$g_{FS}$	$V_{DS} = 10V, I_D = 12A$	30			S
<b>Dynamic characteristics (note 2)</b>						
Input capacitance	$C_{iss}$	$V_{DS} = 15V, V_{GS} = 0V,$ $f = 1MHz$		1265		pF
Output capacitance	$C_{oss}$			600		
Reverse transfer capacitance	$C_{rss}$			130		
<b>Switching characteristics (note 2)</b>						
Total gate charge	$Q_g$	$V_{DS} = 15V, V_{GS} = 10V,$ $I_D = 12A$		19		nC
Gate-source charge	$Q_{gs}$			2.7		
Gate-drain charge	$Q_{gd}$			2.5		
Turn-on delay time	$t_{d(on)}$	$V_{DD} = 15V, I_D = 12A,$ $V_{GS} = 10V, R_G = 6\Omega$		18		ns
Turn-on rise time	$t_r$			10		
Turn-off delay time	$t_{d(off)}$			34		
Turn-off fall time	$t_f$			10		
<b>Drain-Source Diode Characteristics</b>						
Drain-source diode forward voltage(note1)	$V_{SD}$	$V_{GS} = 0V, I_S = 12A$		0.85	1.2	V
Continuous drain-source diode forward current(note3)	$I_S$				35	A
Pulsed drain-source diode forward current	$I_{SM}$				120	A

Notes:

1. Pulse Test : Pulse Width  $\leq 300\mu s$ , duty cycle  $\leq 2\%$ .
2. Guaranteed by design, not subject to production.
3. Surface Mounted on FR4 Board,  $t \leq 10$  sec.



# TYPICAL CHARACTERISTICS

Output Characteristics

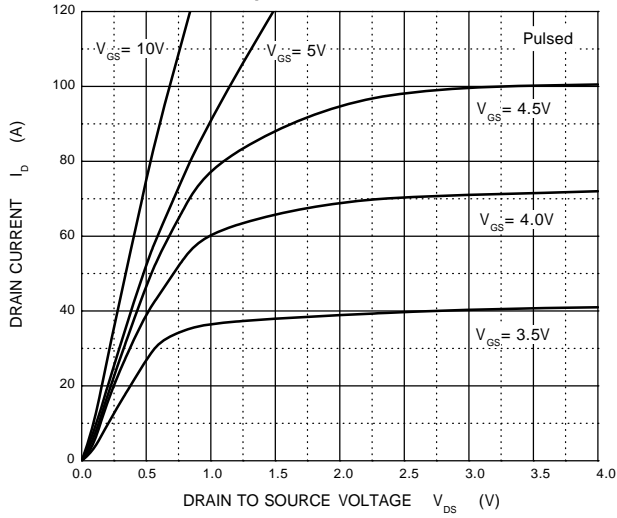

Transfer Characteristics

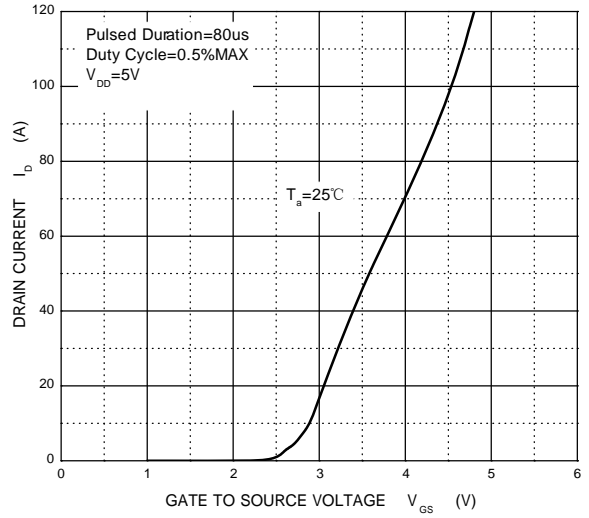

$R_{DS(ON)}$  —  $I_D$

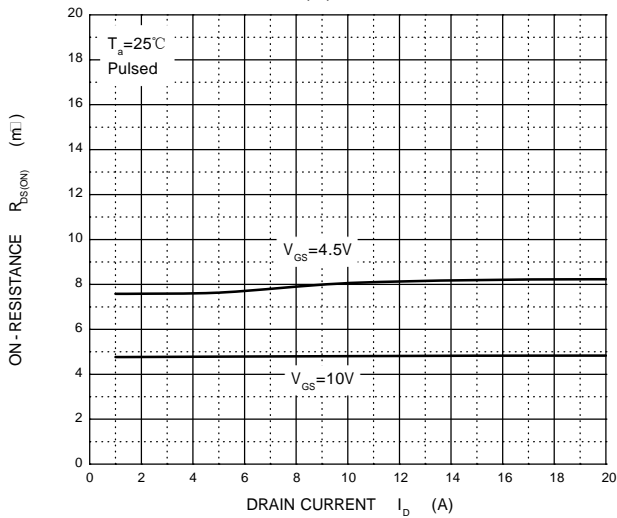

$R_{DS(ON)}$  —  $V_{GS}$

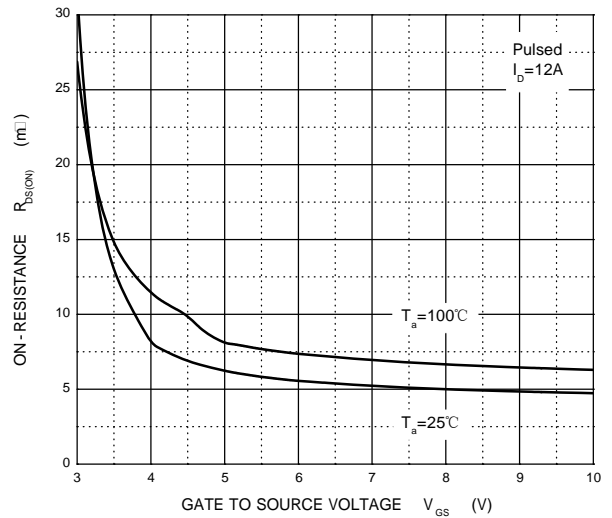

$I_S$  —  $V_{SD}$

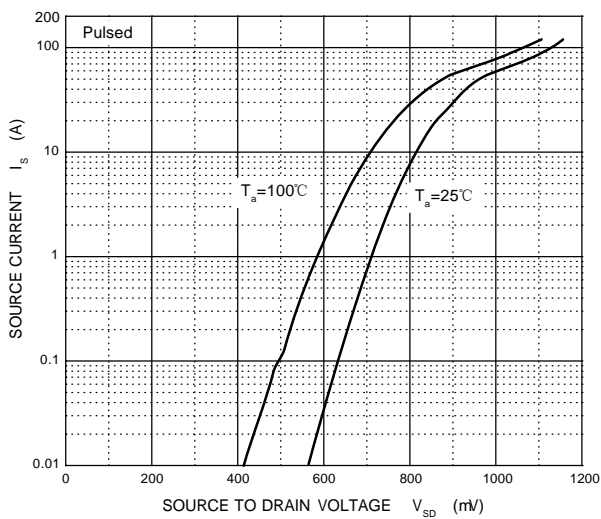

Threshold Voltage

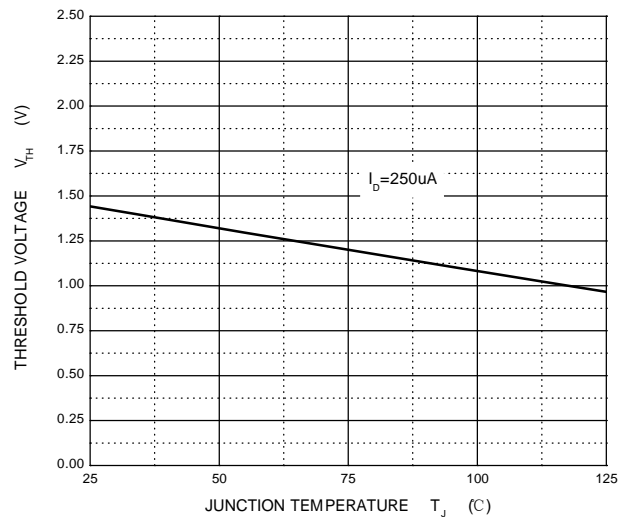

## PDFNWB5x6-8L Package Outline Dimensions

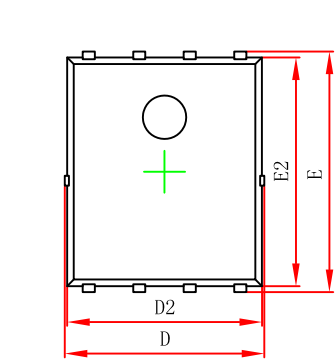

Top View  
[顶视图]

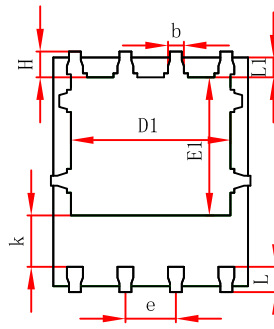

Bottom View  
[背视图]

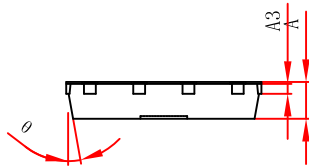

Side View  
[侧视图]

Symbol	Dimensions in Millimeters		Dimensions in Inches	
	Min.	Max.	Min.	Max.
A	0.900 1	1.000	0.035 0	.039
A3	0.254REF		0.010REF	
D	4.944 5	5.096	0.195 0	0.201
E	5.974 6	6.126	0.235 0	0.241
D1	3.910 4	4.110	0.154 0	0.162
E1	3.375 3	3.575	0.133 0	0.141
D2	4.824 4	4.976	0.190 0	0.196
E2	5.674 5	5.826	0.223 0	0.229
k	1.190 1	1.390	0.047	0.055
b	0.350 0	0.450	0.014 0	0.018
e	1.270TYP.		0.050TYP.	
L	0.559 0	0.711	0.022 0	0.028
L1	0.424 0	0.576	0.017 0	0.023
H	0.574 0	0.726	0.023 0	0.029
θ	10°	12°	10°	12°

## PDFNWB5x6-8L Suggested Pad Layout

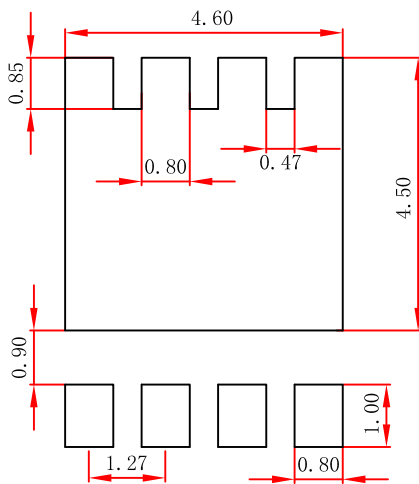

- Note:
1. Controlling dimension: in millimeters.
  2. General tolerance:  $\pm 0.05\text{mm}$ .
  3. The pad layout is for reference purposes only.

## PDFN5×6-8L Tape and Reel

### PDFN5×6-8L Embossed Carrier Tape

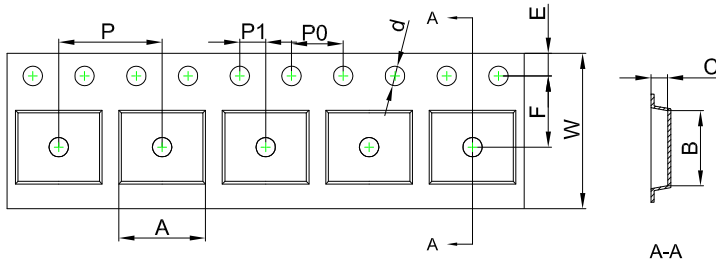

**Packaging Description:**

**PDFN5×6-8L** parts are shipped in tape. The carrier tape is made from a dissipative (carbon filled) polycarbonate resin. The cover tape is a multilayer film (Heat Activated Adhesive in nature) primarily composed of polyester film, adhesive layer, sealant, and anti-static sprayed agent. These reeled parts in standard option are shipped with 5,000 units per 13" or 33.0 cm diameter reel. The reels are clear in color and is made of polystyrene plastic (anti-static coated).

Dimensions are in millimeter										
Pkg type	A	B	C	d	E	F	P0	P	P1	W
<b>PDFN5×6-8L</b>	6.30	5.30	1.10	Ø1.50	1.75	5.50	4.00	8.00	2.00	12.00
(Tolerance)	+/-0.10	+/-0.10	+/-0.10	+0.10/-0.00	+/-0.10	+/-0.05	+/-0.10	+/-0.10	+/-0.05	+0.30/-0.10

### PDFN5×6-8L Tape Leader and Trailer

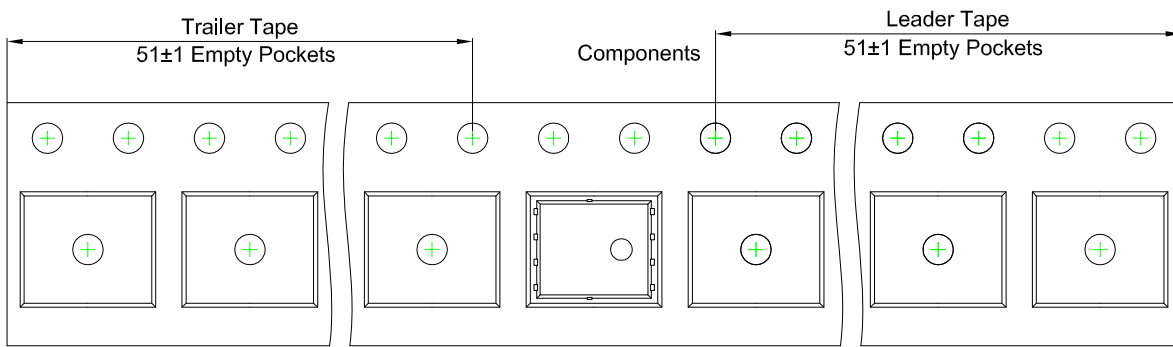

### PDFN5×6-8L Reel

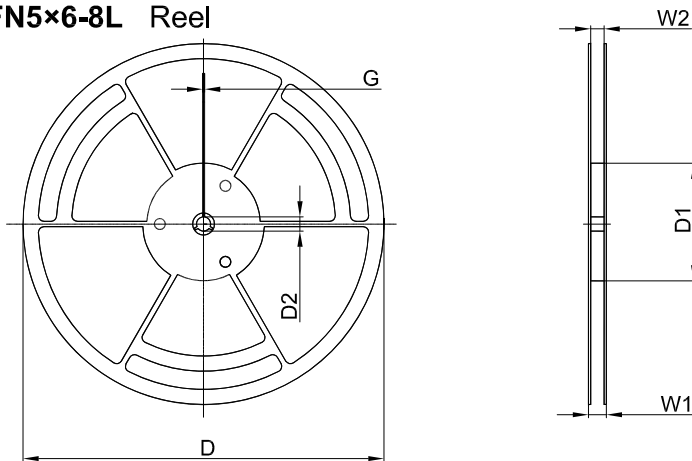

Dimensions are in millimeter						
Reel Option	D	D1	D2	G	W1	W2
13"Dia	Ø330.00	100.00	13.00	1.90	17.60	12.40
Tolerance	+/-1.00	+/-0.50	+/-0.20	+/-0.40	+1.00/-0.00	+1.00/-0.00

REEL	Reel Size	Box	Box Size(mm)	Carton	Carton Size(mm)	G.W.(kg)
5,000 pcs	13 inch	5,000 pcs	340×336×29	50,000 pcs	353×346×365	