

DESCRIPTION

The FTK2306 uses advanced trench technology to provide excellent $R_{DS(ON)}$, low gate charge and operation with gate voltages as low as 2.5V.

GENERAL FEATURES

- $V_{DS} = 30V, I_D = 5A$
 $R_{DS(ON)} < 50m\Omega @ V_{GS}=2.5V$
 $R_{DS(ON)} < 35m\Omega @ V_{GS}=4.5V$
- High Power and current handing capability
- Lead free product is acquired
- Surface Mount Package

Application

- Battery protection
- Load switch
- Power management

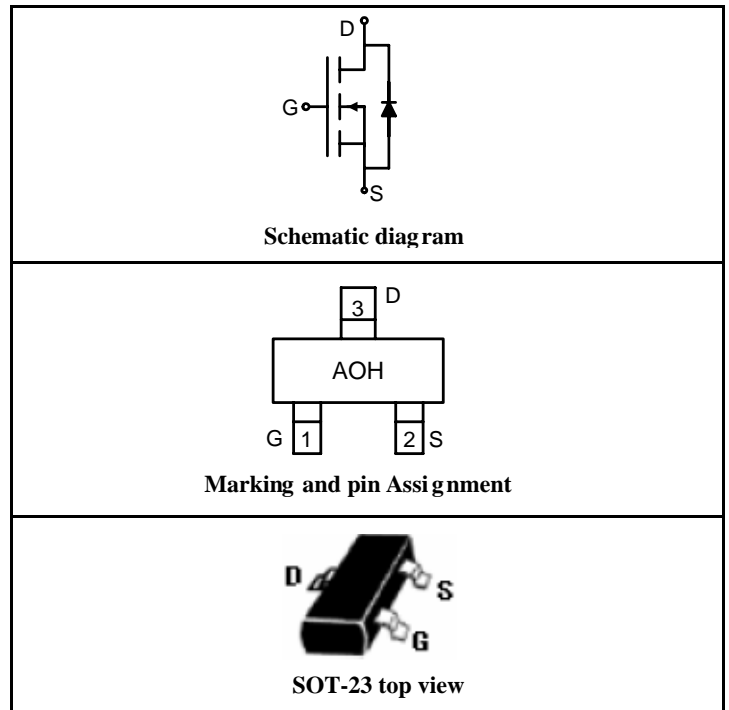

PACKAGE MARKING AND ORDERING INFORMATION

Device Marking	Device	Device Package	Reel Size	Tape width	Quantity
AOH	FTK2306	SOT-23	Ø180mm	8 mm	3000 units

ABSOLUTE MAXIMUM RATINGS(TA=25°C unless otherwise noted)

Parameter	Symbol	Limit	Unit
Drain-Source Voltage	V_{DS}	30	V
Gate-Source Voltage	V_{GS}	±12	V
Drain Current-Continuous@ Current-Pulsed (Note 1)	I_D	5	A
	I_{DM}	20	A
Maximum Power Dissipation	P_D	1.38	W
Operating Junction and Storage Temperature Range	T_J, T_{STG}	-55 To 150	°C

THERMAL CHARACTERISTICS

Thermal Resistance, Junction-to-Ambient (Note 2)	$R_{\theta JA}$	90	°C/W
--	-----------------	----	------

ELECTRICAL CHARACTERISTICS (TA=25°C unless otherwise noted)

Parameter	Symbol	Condition	Min	Typ	Max	Unit
OFF CHARACTERISTICS						
Drain-Source Breakdown Voltage	BV_{DSS}	$V_{GS}=0V, I_D=250\mu A$	30			V
Zero Gate Voltage Drain Current	I_{DSS}	$V_{DS}=30V, V_{GS}=0V$			1	µA
Gate-Body Leakage Current	I_{GSS}	$V_{GS}=\pm 12V, V_{DS}=0V$			±100	nA
ON CHARACTERISTICS (Note 3)						
Gate Threshold Voltage	$V_{GS(th)}$	$V_{DS}=V_{GS}, I_D=250\mu A$	0.5		1.2	V
Drain-Source On-State Resistance	$R_{DS(ON)}$	$V_{GS}=2.5V, I_D=2.6A$			50	mΩ
		$V_{GS}=4.5V, I_D=5A$			35	mΩ
		$V_{GS}=10V, I_D=5A$			30	mΩ
Forward Transconductance	g_{FS}	$V_{DS}=5V, I_D=5A$		13		S

DYNAMIC CHARACTERISTICS (Note4)					
Input Capacitance	C_{iss}	$V_{DS}=25V, V_{GS}=0V,$ $F=1.0MHz$	660	1050	PF
Output Capacitance	C_{oss}		90		PF
Reverse Transfer Capacitance	C_{rss}		70		PF
SWITCHING CHARACTERISTICS (Note 4)					
Turn-on Delay Time	$t_{d(on)}$	$V_{DS}=15V, I_D=5A$ $V_{GS}=10V, R_{GEN}=3.3\Omega$ $R_D=3\Omega$	6		nS
Turn-on Rise Time	t_r		20		nS
Turn-Off Delay Time	$t_{d(off)}$		20		nS
Turn-Off Fall Time	t_f		3		nS
Total Gate Charge	Q_g	$V_{DS}=16V, I_D=5A, V_{GS}=4.5V$	8.5	15	nC
Gate-Source Charge	Q_{gs}		1.5		nC
Gate-Drain Charge	Q_{gd}		3.2		nC
DRAIN-SOURCE DIODE CHARACTERISTICS					
Diode Forward Voltage (Note 3)	V_{SD}	$V_{GS}=0V, I_S=1.2A$		1.2	V

NOTES:

1. Repetitive Rating: Pulse width limited by maximum junction temperature.
2. Surface Mounted on FR4 Board, $t \leq 10$ sec.
3. Pulse Test: Pulse Width $\leq 300\mu s$, Duty Cycle $\leq 2\%$.
4. Guaranteed by design, not subject to production testing.

TYPICAL ELECTRICAL AND THERMAL CHARACTERISTICS

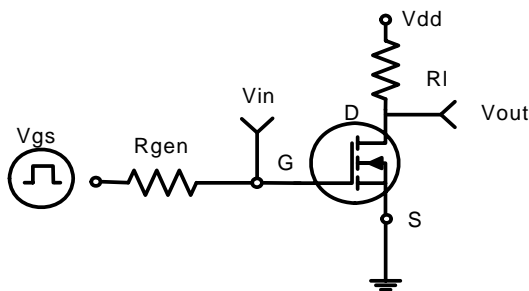

Figure 1: Switching Test Circuit

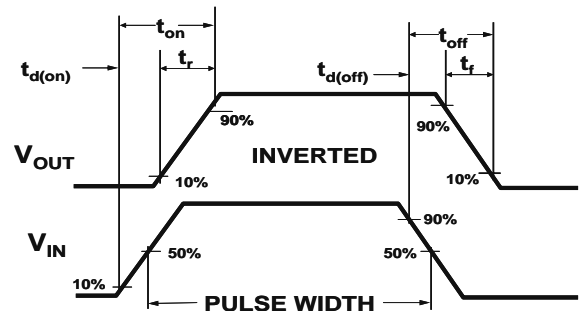

Figure 2: Switching Waveforms

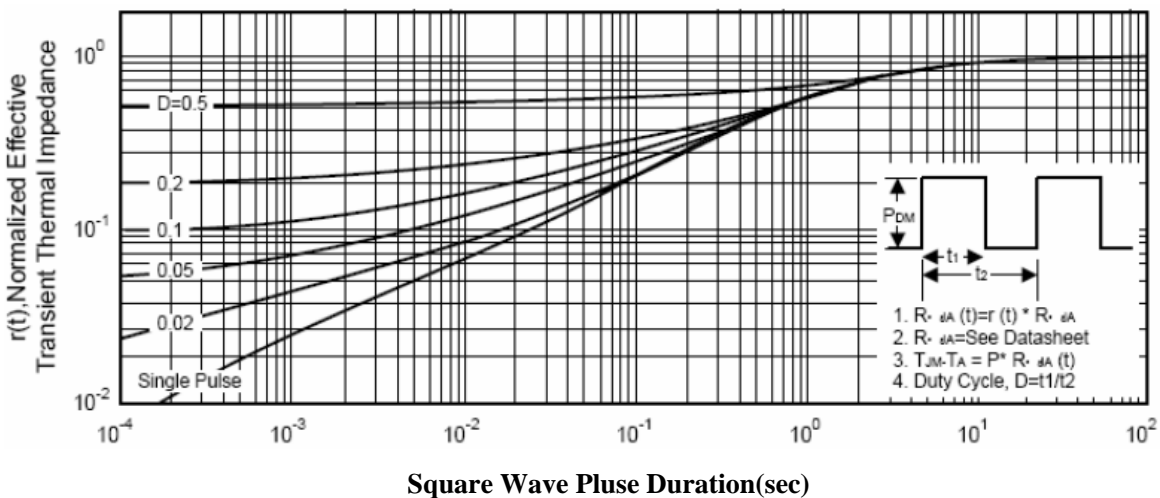

Figure 3: Normalized Maximum Transient Thermal Impedance

TYPICAL ELECTRICAL CHARACTERISTICS

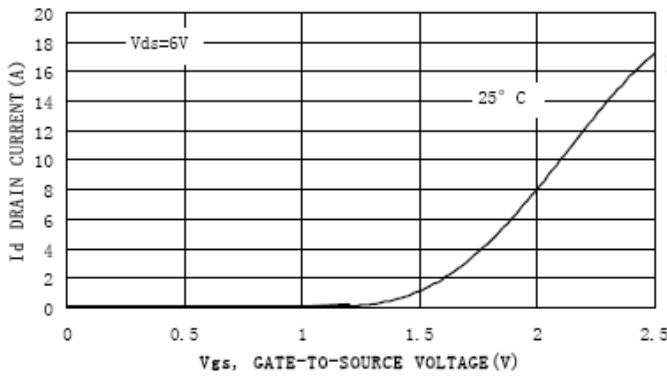

Figure 1. Transfer Characteristics

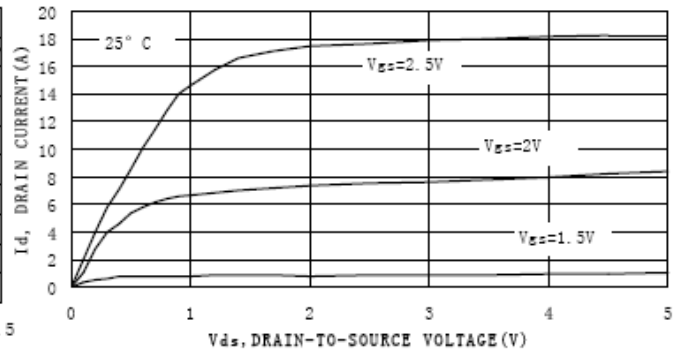

Figure 2. On-Region Characteristics

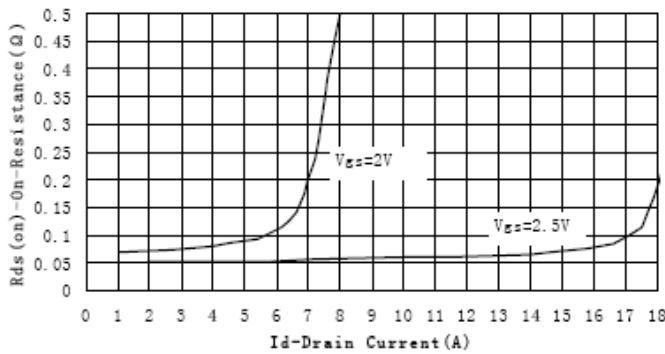

Figure 3. On-Resistance versus Drain Current

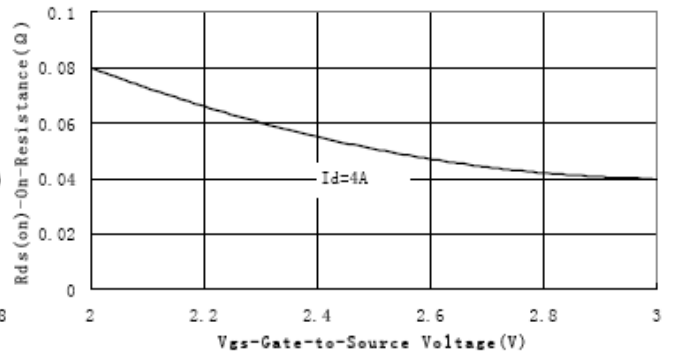
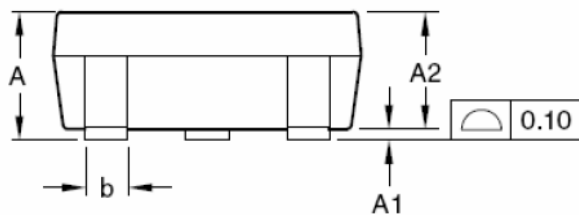
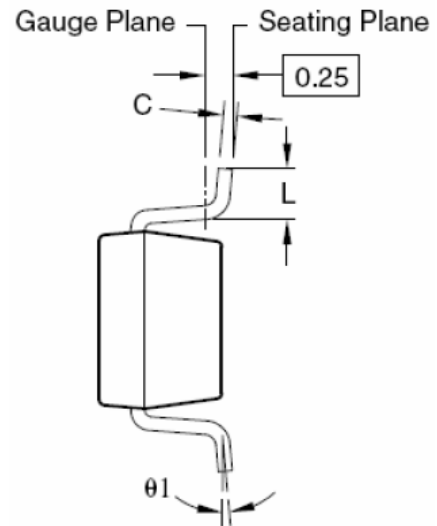
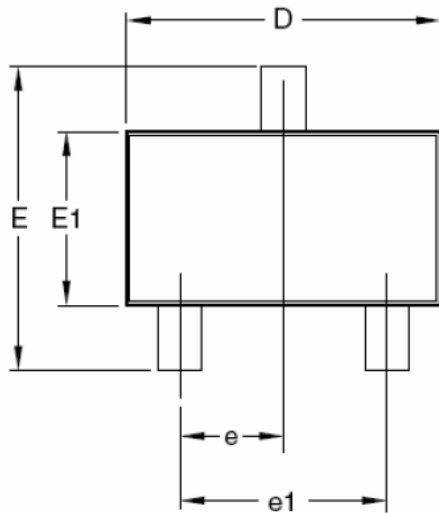

Figure 4. On-Resistance vs. Gate-to-Source Voltage

SOT-23 PACKAGE INFORMATION

Dimensions in Millimeters (UNIT:mm)



RECOMMENDED LAND PATTERN

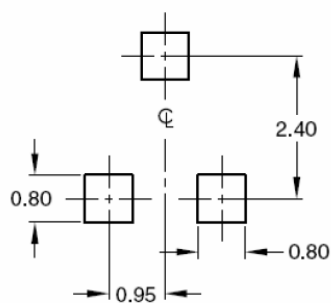

UNIT: mm

Dimensions in millimeters

Symbols	Min.	Nom.	Max.
A	0.90	—	1.25
A1	0.00	—	0.13
A2	0.70	1.00	1.15
b	0.30	0.40	0.50
C	0.08	0.13	0.20
D	2.80	2.90	3.10
E	2.60	2.80	3.00
E1	1.40	1.60	1.80
e	0.95 BSC		
e1	1.90 BSC		
L	0.30	—	0.60
θ1	0°	5°	8°

Dimensions in inches

Symbols	Min.	Nom.	Max.
A	0.035	—	0.049
A1	0.000	—	0.005
A2	0.028	0.039	0.045
b	0.012	0.016	0.020
C	0.003	0.005	0.008
D	0.110	0.114	0.122
E	0.102	0.110	0.118
E1	0.055	0.063	0.071
e	0.037 BSC		
e1	0.075 BSC		
L	0.012	—	0.024
θ1	0°	5°	8°

NOTES:

- All dimensions are in millimeters.
- Tolerance $\pm 0.10\text{mm}$ (4 mil) unless otherwise specified
- Package body sizes exclude mold flash and gate burrs. Mold flash at the non-lead sides should be less than 5 mils.
- Dimension L is measured in gauge plane.
- Controlling dimension is millimeter, converted inch dimensions are not necessarily exact.