

# N-Channel Enhancement Mode MOSFET

## 1. Product Information

### 1.1 Features

- Surface-mounted package
- Super Trench
- Tj max 175°C
- Advanced trench cell design
- MSL1

### 1.2 Applications

- Power appliances
- E- Tool appliances
- High power inverter system
- BMS

### 1.3 Quick reference

- $BV \geq 60 \text{ V}$
- $P_{tot} \leq 375 \text{ W}$
- $I_D \leq 500 \text{ A}$
- $R_{DS(ON)} \leq 0.68 \text{ m}\Omega @ V_{GS} = 10 \text{ V}$
- $R_{DS(ON)} \leq 1.25 \text{ m}\Omega @ V_{GS} = 6 \text{ V}$

## 2. Pin Description

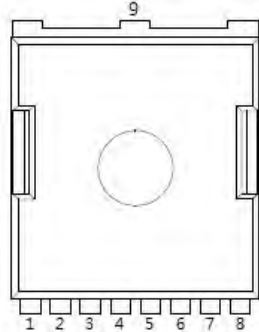
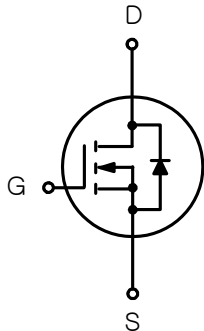
Pin	Description	Simplified Outline	Symbol
1	Gate(G)	 <p style="text-align: center;"><b>Top View</b> <b>TOLL</b></p>	
2,3,4,5,6,7,8	Source(S)		
9	Drain(D)		

### 3. Limiting Values

Symbol	Parameter	Conditions	Min	Max	Unit
$V_{DS}$	Drain-Source Voltage	$T_C = 25\text{ }^\circ\text{C}$	-	60	V
$V_{GS}$	Gate-Source Voltage	$T_C = 25\text{ }^\circ\text{C}$	-	$\pm 20$	V
$I_{D*}$	Drain Current ( DC )	$T_C = 25\text{ }^\circ\text{C}, V_{GS} = 10\text{ V}$	-	500	A
		$T_C = 100\text{ }^\circ\text{C}, V_{GS} = 10\text{ V}$	-	362	A
$I_{DM***}$	Drain Current ( Pulsed )	$T_C = 25\text{ }^\circ\text{C}, V_{GS} = 10\text{ V}$	-	1600	A
$P_{tot*}$	Drain power dissipation	$T_C = 25\text{ }^\circ\text{C}$	-	375	W
$T_{stg}$	Storage Temperature		- 55	175	$^\circ\text{C}$
$T_J$	Junction Temperature		-	175	$^\circ\text{C}$
$I_S$	Continuous-Source Current	$T_C = 25\text{ }^\circ\text{C}$	-	500	A
$E_{AS*}$	Single Pulsed Avalanche Energy	$V_{DD} = 50\text{ V}, L = 1\text{ mH}$	-	2738	mJ
$R_{\theta JA*}$	Thermal Resistance- Junction to Ambient		-	40	$^\circ\text{C}/\text{W}$
$R_{\theta JC*}$	Thermal Resistance- Junction to Case		-	0.4	

Notes :

\* Surface Mounted on 1 in<sup>2</sup> pad area,  $t \leq 10\text{ sec}$

\*\* Pulse width  $\leq 300\text{ }\mu\text{s}$ , duty cycle  $\leq 2\%$

\*\*\* Limited by bonding wire

### 4. Marking Information

Product Name	Marking
FTN006N06TH	

### 5. Ordering Code

Product Name	Package	Reel Size	Tape width	Quantity	Note
FTN006N06TH	TOLL-8L			2000	

**6. Electrical Characteristics** (  $T_A=25^\circ$  Unless Otherwise Noted )

Symbol	Parameter	Conditions	Min	Typ	Max	Unit
<b>Static Characteristics</b>						
$BV_{DSS}$	Drain-Source Breakdown Voltage	$V_{GS} = 0\text{ V}, I_{DS} = 250\ \mu\text{A}$	60	-	-	V
$V_{GS(th)}$	Gate Threshold Voltage	$V_{DS} = V_{GS}, I_{DS} = 250\ \mu\text{A}$	2	-	4	V
$I_{DSS}$	Drain Leakage Current	$V_{DS} = 48\text{ V}, V_{GS} = 0\text{ V}$	-	-	1	$\mu\text{A}$
$I_{GSS}$	Gate Leakage Current	$V_{DS} = 0\text{ V}, V_{GS} = \pm 20\text{ V}$	-	-	$\pm 100$	nA
$R_{DS(on)}^a$	On-State Resistance	$V_{GS} = 10\text{ V}, I_{DS} = 20\text{ A}$	-	0.60	0.68	m $\Omega$
		$V_{GS} = 6\text{ V}, I_{DS} = 10\text{ A}$	-	1.06	1.25	
<b>Diode Characteristics</b>						
$V_{SD}^a$	Diode Forward Voltage	$I_{SD} = 20\text{ A}, V_{GS} = 0\text{ V}$	-	-	1.3	V
$t_{rr}$	Reverse Recovery Time	$I_{DS} = 20\text{ A}, V_{GS} = 0\text{ V}$ $dI_{SD}/dt = 100\text{ A}/\mu\text{s}$	-	115	-	nS
$Q_{rr}$	Reverse Recovery Charge		-	377	-	nC
<b>Dynamic Characteristics</b>						
$C_{iss}$	Input Capacitance	$V_{GS} = 0\text{ V}, V_{DS} = 30\text{ V}$ Frequency = 1 MHz	-	17306	-	pF
$C_{oss}$	Output Capacitance		-	4764	-	
$C_{riss}$	Reverse Transfer Capacitance		-	2000	-	
$t_d(on)$	Turn-on Delay Time	$V_{DS} = 30\text{ V}, V_{GEN} = 10\text{ V},$ $R_G = 3.9\ \Omega, R_L = 1.5\ \Omega,$ $I_{DS} = 20\text{ A}$	-	46	-	nS
$t_r$	Turn-on Rise Time		-	73	-	
$t_d(off)$	Turn-off Delay Time		-	161	-	
$t_f$	Turn-off Fall Time		-	88	-	
<b>Gate Charge Characteristics</b>						
$Q_g$	Total Gate Charge	$V_{DS} = 30\text{ V}, V_{GS} = 10\text{ V},$ $I_{DS} = 20\text{ A}$	-	274	-	nC
$Q_{gs}$	Gate-Source Charge		-	96	-	
$Q_{gd}$	Gate-Drain Charge		-	53	-	

Notes :

a : Pulse test ; pulse width  $\leq 300\ \mu\text{s}$ , duty cycle  $\leq 2\%$ 

b : Guaranteed by design, not subject to production testing

## 7. Typical Characteristics

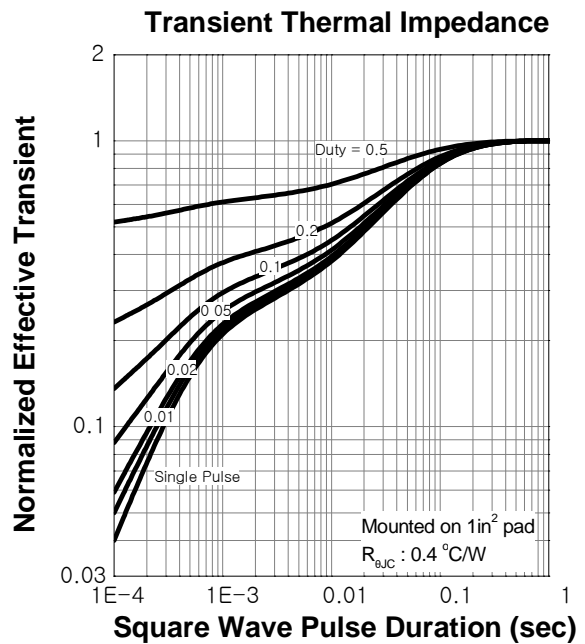
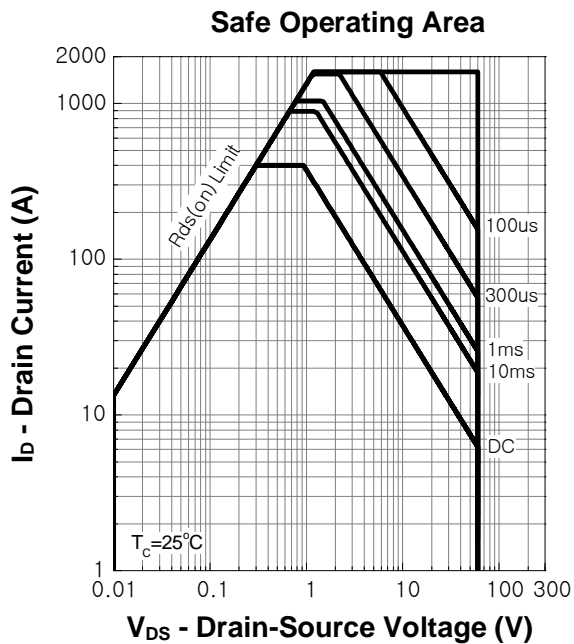
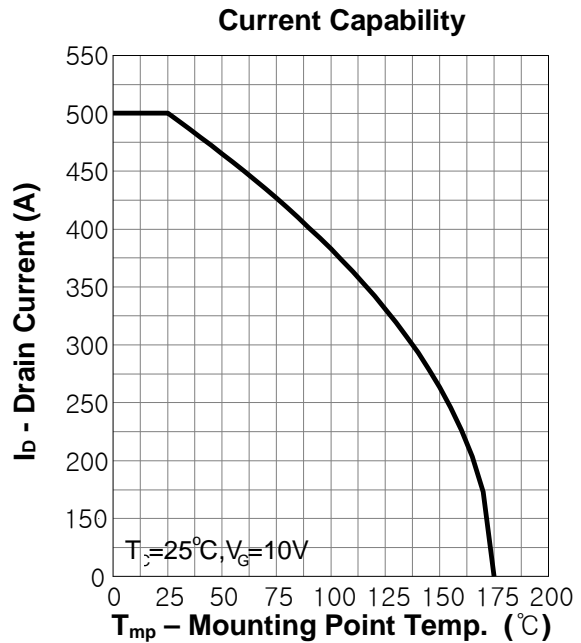
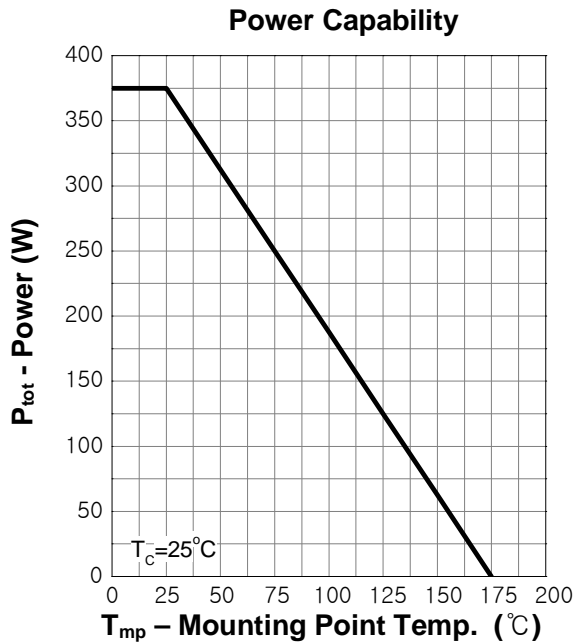

## 7. Typical Characteristics (cont.)

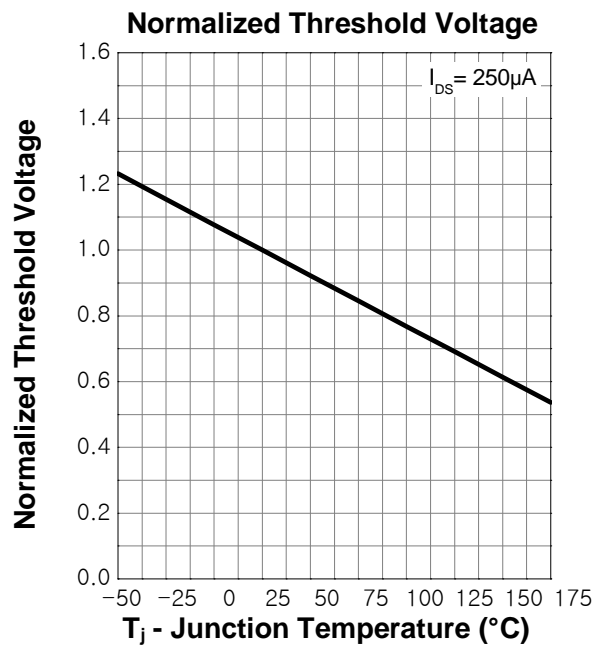
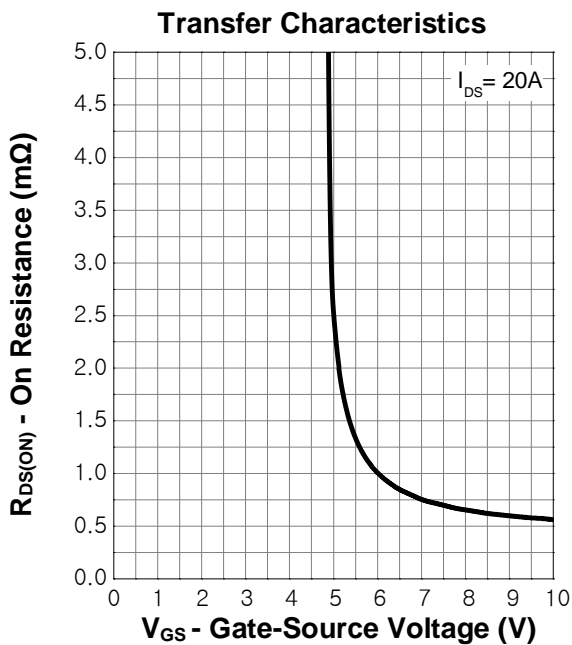
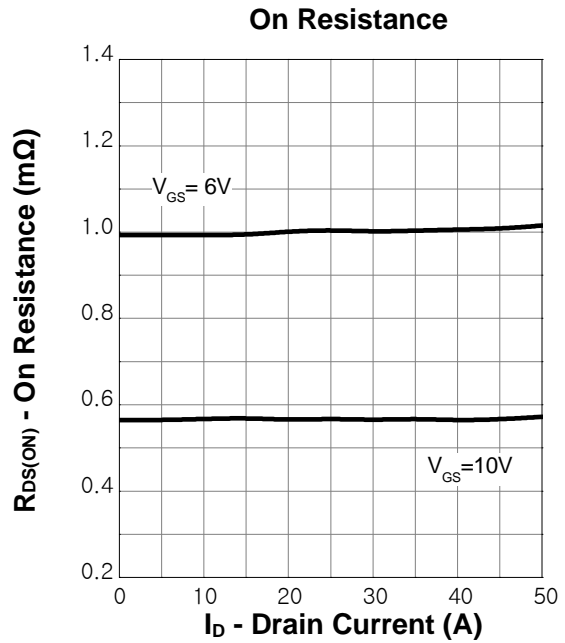
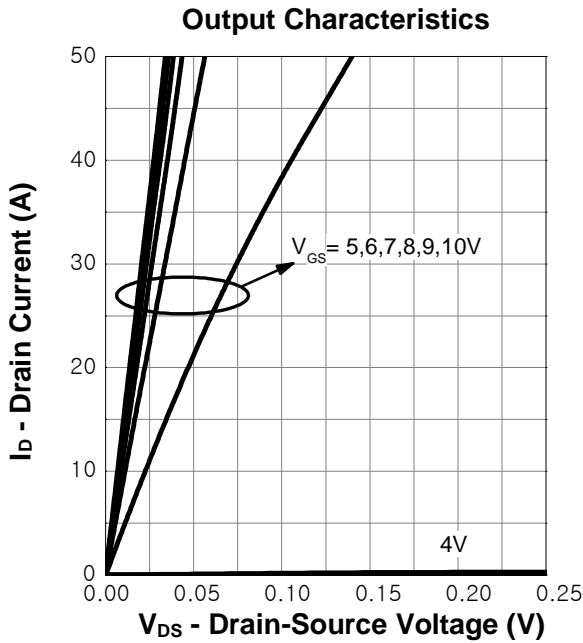

## 7. Typical Characteristics (cont.)

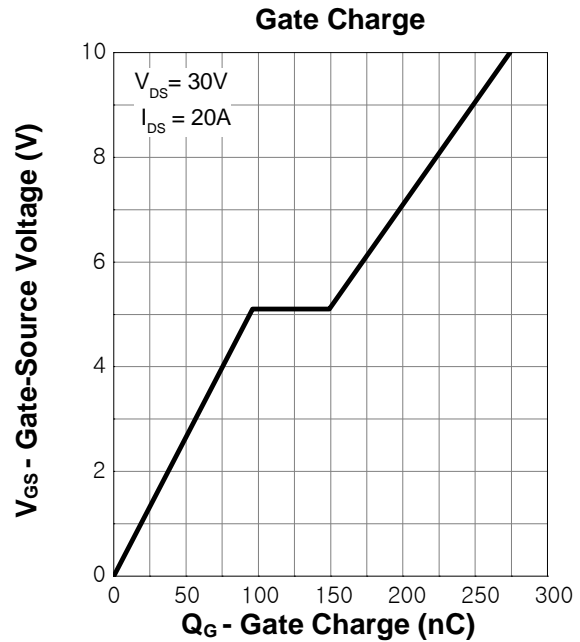
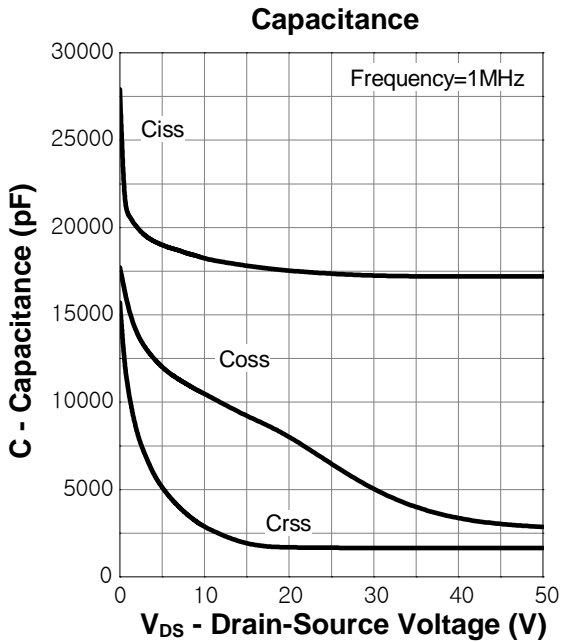
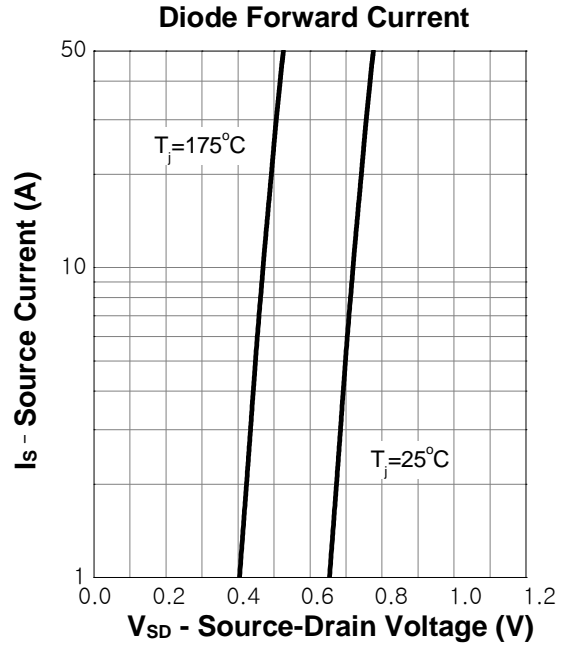
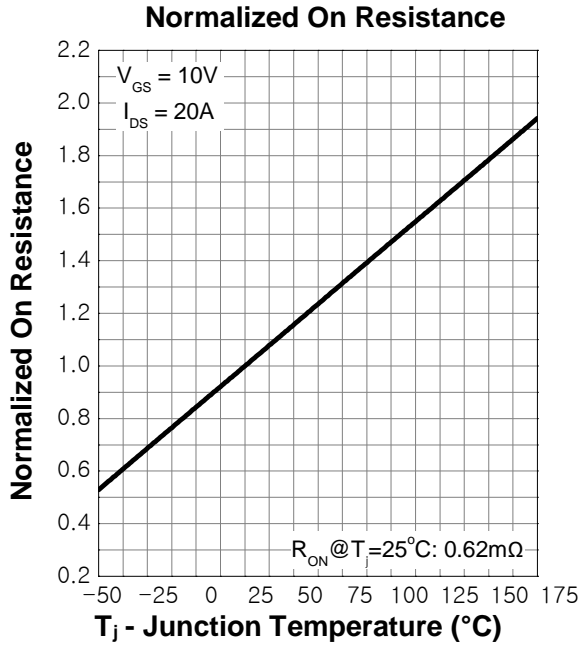





## 8. Package Dimensions

TOLL-8L Package

Symbol	Dimensions In Millimeters			Dimensions In INCHES		
	MIN.	NOM.	MAX.	MIN.	NOM.	MAX.
A	2.200	2.300	2.400	0.087	0.091	0.094
c	0.492	0.500	0.508	0.019	0.020	0.021
D	10.280	10.380	10.480	0.405	0.409	0.413
E	9.800	9.900	10.000	0.386	0.390	0.394
e	1.20 BSC			0.047 BSC		
H	11.580	11.680	11.780	0.456	0.460	0.464
H1	6.650	6.750	6.850	0.262	0.266	0.270
H2	7.300			0.287		
H3	3.200			0.126		
H4	3.800			0.150		
K1	4.180			0.165		
K2	2.900			0.114		
D2	3.300			0.130		
b	0.700	0.800	0.900	0.028	0.031	0.035
b1	9.700	9.800	9.900	0.382	0.386	0.390
b2	0.420	0.460	0.500	0.017	0.018	0.020
b3	0.350			0.014		
b4	0.600			0.024		
b5	3.100			0.122		
b6	1.200			0.047		
L	1.700	1.900	2.100	0.067	0.075	0.083
L1	0.700			0.028		
L2	0.600			0.024		
L4	1.050	1.150	1.250	0.041	0.045	0.049
L5	0.500	0.600	0.700	0.020	0.024	0.028
E1	7.800			0.310		
E4	8.800			0.350		
E5	9.200			0.360		