

Power MOSFET

**7.0 Amps, 600 Volts
N-CHANNEL MOSFET**

■ **DESCRIPTION**

The FTK 7N60 is a high voltage MOSFET and is designed to have better characteristics, such as fast switching time, low gate charge, low on-state resistance and have a high rugged avalanche characteristics. This power MOSFET is usually used at high speed switching applications in switching power supplies and adaptors.

■ **FEATURES**

- * $R_{DS(ON)} = 1.2\Omega @ V_{GS} = 10V$
- * Low gate and reverse transfer Capacitance (C: 10 pF typical)
- * Fast switching capability
- * Avalanche energy tested
- * Improved dv/dt capability, high ruggedness

■ **SYMBOL**

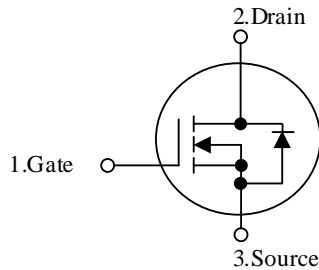

■ **ORDERING INFORMATION**

Order Number	Package	Pin Assignment			Packing
		1	2	3	
FTK7N60P	TO-220	G	D	S	Tube
FTK7N60F	TO-220F	G	D	S	Tube
FTK7N60DD	TO-263	G	D	S	Reel & Taping

Note: Pin Assignment: G: Gate D: Drain S: Source

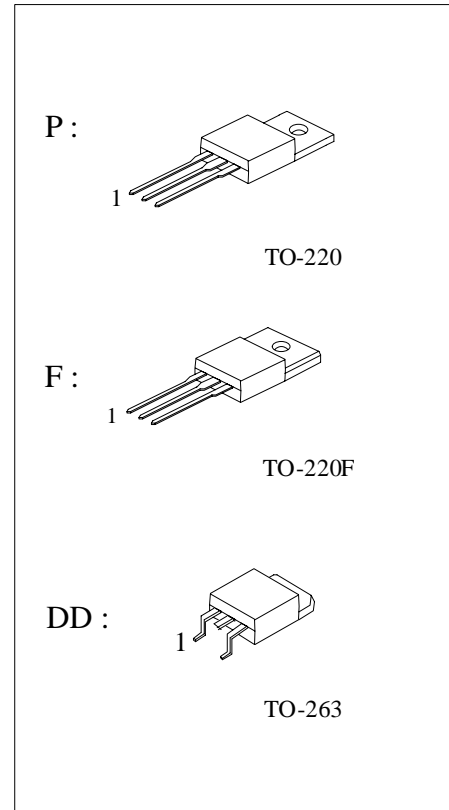



FTK7N60P / F / DD

Power MOSFET

■ ABSOLUTE MAXIMUM RATINGS (T_C = 25°C, unless otherwise specified)

PARAMET		SYMBOL	RATINGS	UNIT
Drain-Source Voltage		V _{DSS}	600	V
Gate-Source Voltage		V _{GSS}	±30	V
Avalanche Current (Note 1)		I _{AR}	7.0	A
Continuous Drain Current	T _C = 25°C	I _D	7.0	A
	T _C = 100°C		4.2	
Pulsed Drain Current (Note 1)		I _{DM}	28	A
Avalanche Energy	Single Pulse(Note 2)	E _{AS}	230	mJ
	Repetitive Limited by T _{J(MAX)}	E _{AR}	14.7	mJ
Peak Diode Recovery dv/dt (Note 3)		dv/dt	4.5	V/ns
Power Dissipation (TO-220,TO-263/ TO-220F)	T _C = 25°C	P _D	142 / 48	W
	Derate above 25°C		1.14 / 0.38	
Junction Temperature		T _J	+150	°C
Operating and Storage Temperature		T _{STG}	-55 ~ +150	°C

Note: Absolute maximum ratings are those values beyond which the device could be permanently damaged.

Absolute maximum ratings are stress ratings only and functional device operation is not implied.

■ THERMAL DATA

PARAMETER		SYMBOL	MIN	TYP	MAX	UNIT
Junction-to-Ambient		θ _{JA}			62.5	°C / W
Junction-to-Case	TO-220, TO-263	θ _{Jc}			0.88	
	TO-220F	θ _{Jc}			2.6	

■ ELECTRICAL CHARACTERISTICS (T_C = 25°C, unless Otherwise specified.)

PARAMETER		SYMBOL	TEST CONDITIONS	MIN	TYP	MAX	UNIT
OFF CHARACTERISTICS							
Drain-Source Breakdown Voltage		BV _{DSS}	V _{GS} = 0V, I _D = 250μA	600			V
Drain-Source Leakage Current		I _{DSS}	V _{DS} = 600V, V _{GS} = 0V			1	μA
			V _{DS} = 480V, T _C = 125°C			10	μA
Gate-Body Leakage Current	Forward	I _{GSSF}	V _{GS} = 30V, V _{DS} = 0V			100	nA
	Reverse	I _{GSSR}	V _{GS} = -30V, V _{DS} = 0V			-100	nA
Breakdown Voltage Temperature Coefficient		ΔBV _{DSS} / ΔT _J	I _D = 250μA, Referenced to 25°C		0.7		V / °C
ON CHARACTERISTICS							
Gate Threshold Voltage		V _{GS(TH)}	V _{DS} = V _{GS} , I _D = 250μA	2.0		4.0	V
Static Drain-Source On-Resistance		R _{DS(ON)}	V _{GS} = 10V, I _D = 3.5A		1.0	1.2	Ω
Forward Transconductance		g _{FS}	V _{DS} = 50V, I _D = 3.5A (Note 4)		6.4		S
DYNAMIC CHARACTERISTICS							
Input Capacitance		C _{ISS}	V _{DS} = 25V, V _{GS} = 0V, f = 1.0MHz		1000		pF
Output Capacitance		C _{OSS}			100		pF
Reverse Transfer Capacitance		C _{RSS}			10		pF
SWITCHING CHARACTERISTICS							
Turn-On Delay Time		t _{D(ON)}	V _{DD} = 300V, I _D = 7A, R _G = 25Ω (Note 4,5)		20		ns
Turn-On Rise Time		t _r			40		ns
Turn-Off Delay Time		t _{D(OFF)}			120		ns
Turn-Off Fall Time		t _f			50		ns
Total Gate Charge		Q _G			30		nC
Gate-Source Charge		Q _{GS}	V _{DS} = 480V, I _D = 7A, V _{GS} = 10V (Note 4,5)		5		nC
Gate-Drain Charge		Q _{GD}			10		nC



Power MOSFET

■ ELECTRICAL CHARACTERISTICS(Cont.)

PARAMETER	SYMBOL	TEST CONDITIONS	MIN	TYP	MAX	UNIT
DRAIN-SOURCE DIODE CHARACTERISTICS AND MAXIMUM RATINGS						
Drain-Source Diode Forward Voltage	V_{SD}	$V_{GS} = 0\text{ V}, I_S = 7.0\text{ A}$			1.5	V
Maximum Continuous Drain-Source Diode Forward Current	I_S				7.0	A
Maximum Pulsed Drain-Source Diode Forward Current	I_{SM}				28	A
Reverse Recovery Time	t_{RR}	$V_{GS} = 0\text{ V}, I_S = 7.0\text{ A},$		400		ns
Reverse Recovery Charge	Q_{RR}	$dI_F/dt = 100\text{ A}/\mu\text{s}$ (Note 4)		4.0		μC

Note:

1. Repetitive Rating : Pulse width limited by maximum junction temperature
2. $L = 19.5\text{mH}, I_{AS} = 7\text{A}, V_{DD} = 50\text{V}, R_G = 25\ \Omega$, Starting $T_J = 25^\circ\text{C}$
3. $I_{SD} \leq 7\text{A}, di/dt \leq 300\text{A}/\mu\text{s}, V_{DD} \leq BV_{DSS}$, Starting $T_J = 25^\circ\text{C}$
4. Pulse Test: Pulse width $\leq 300\mu\text{s}$, Duty cycle $\leq 2\%$
5. Essentially independent of operating temperature

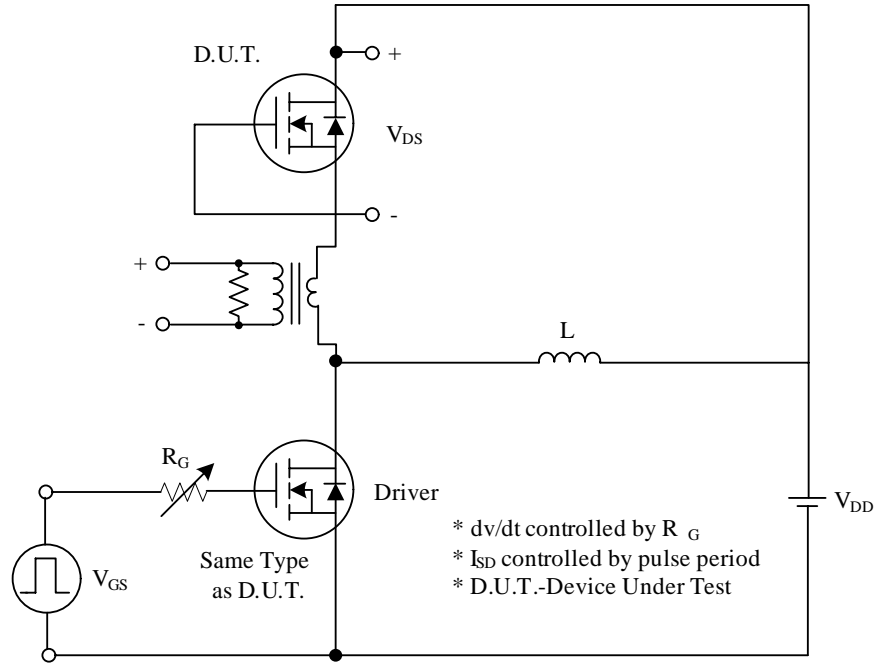

Fig. 1A Peak Diode Recovery dv/dt Test Circuit

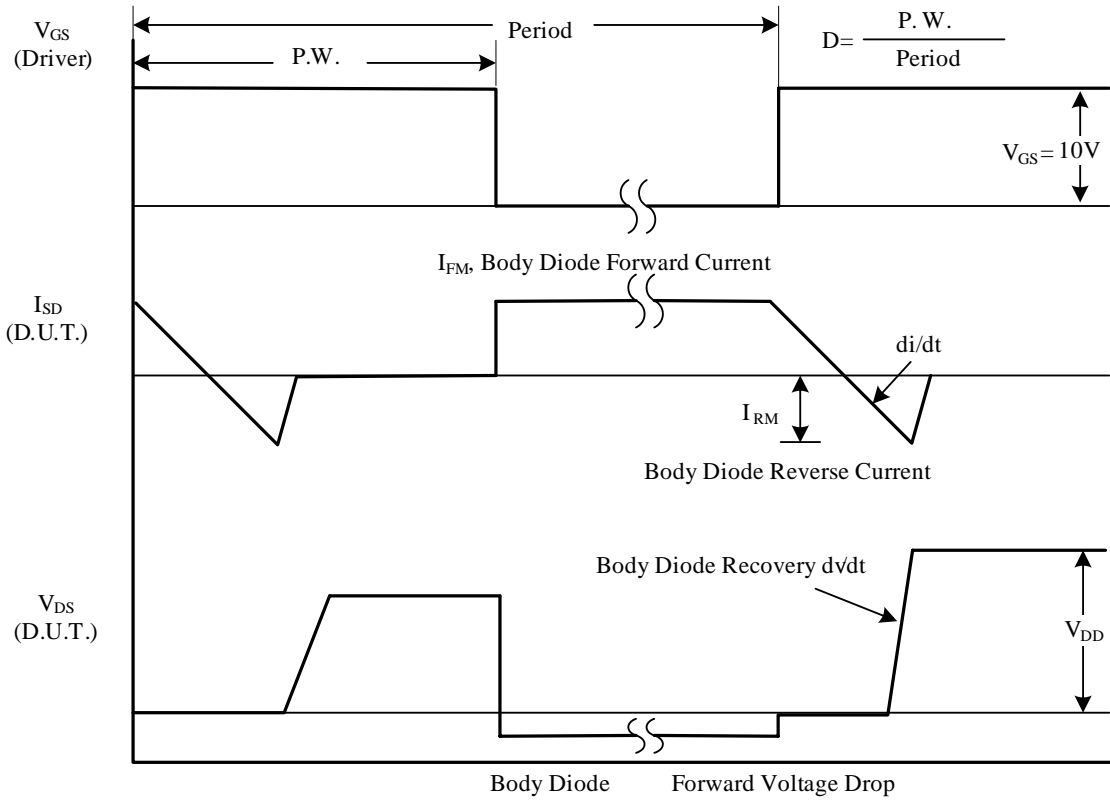

Fig. 1B Peak Diode Recovery dv/dt Waveforms

TEST CIRCUITS AND WAVEFORMS (Cont.)

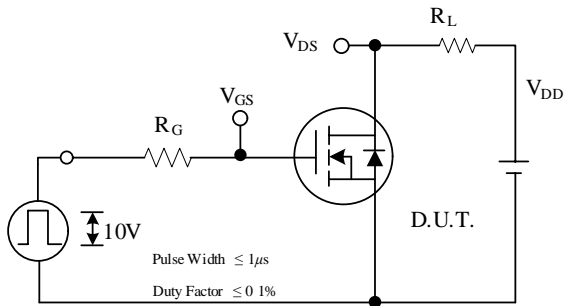

Fig. 2A Switching Test Circuit

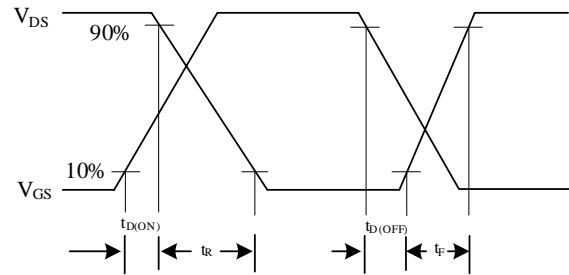

Fig. 2B Switching Waveforms

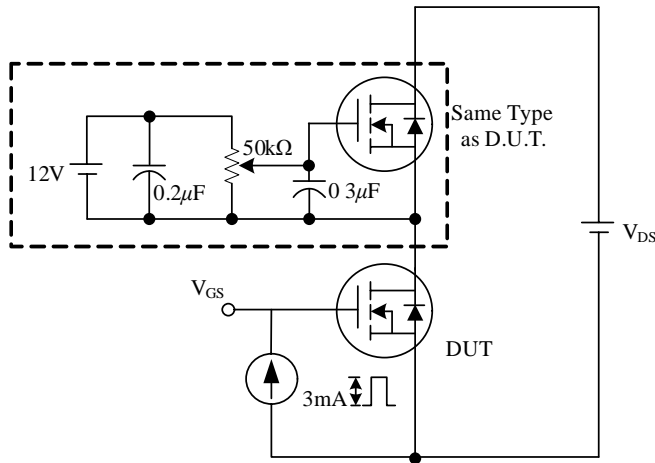

Fig. 3A Gate Charge Test Circuit

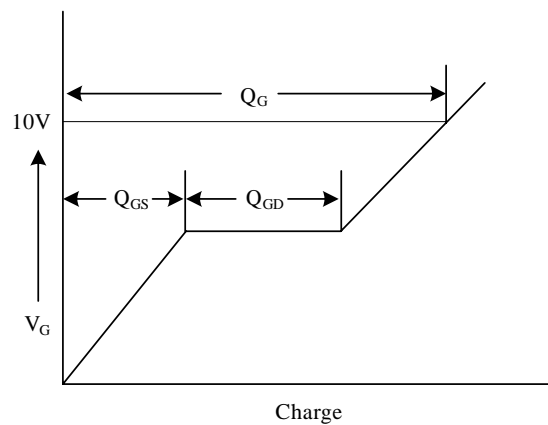

Fig. 3B Gate Charge Waveform

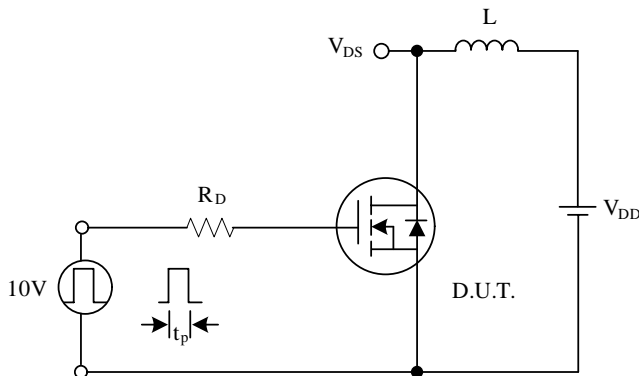

Fig. 4A Unclamped Inductive Switching Test Circuit

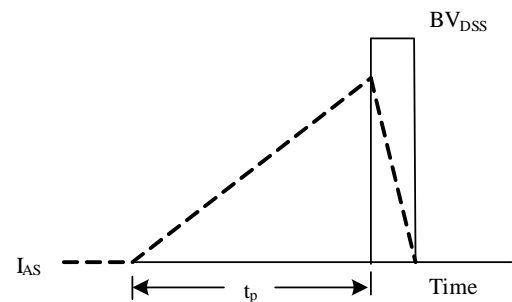

Fig. 4B Unclamped Inductive Switching Waveforms



FTK7N60P / F / DD

Power MOSFET

On-Region Characteristics

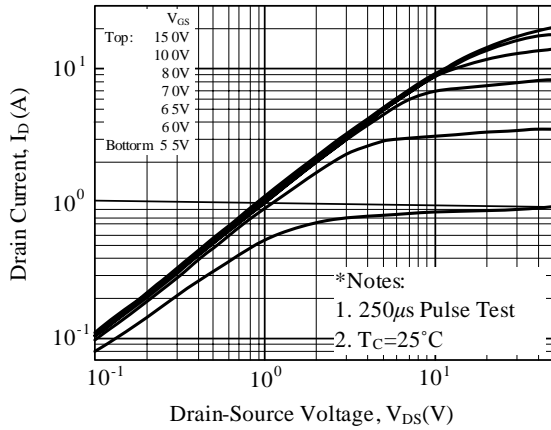

Transfer Characteristics

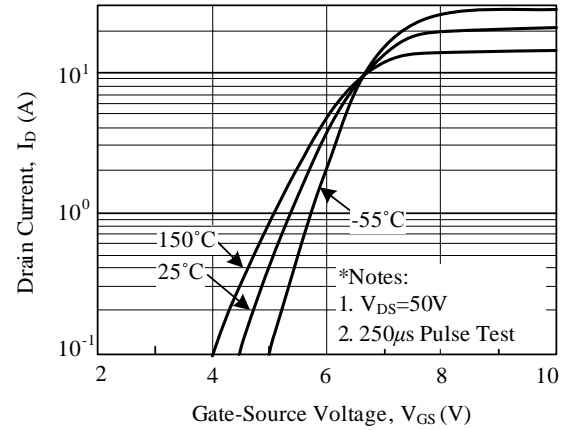

On-Resistance Variation vs Drain Current and Gate Voltage

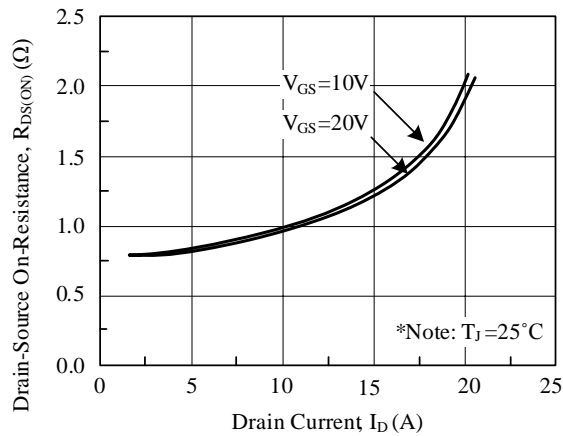

Body Diode Forward Voltage Variation vs Source Current and Temperature

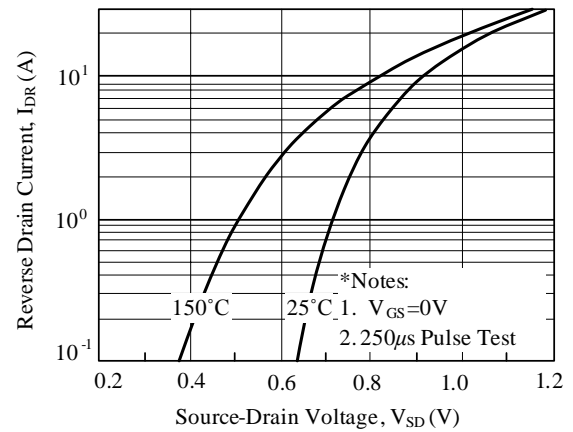

Capacitance Characteristics

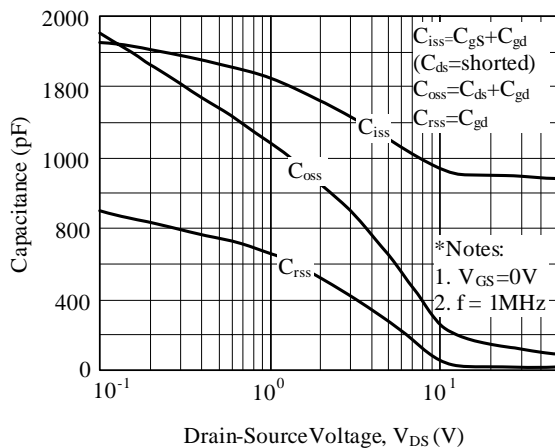

Maximum Safe Operating Area

