

SWITCHING REGULATOR APPLICATIONS

Features

- High Voltage : $BV_{DSS}=650V(\text{Min.})$
- Low C_{RSS} : $C_{RSS}=14pF(\text{Typ.})$
- Low gate charge : $Q_g=12nC(\text{Typ.})$
- Low $R_{DS(on)}$: $R_{DS(on)}=2.6\Omega(\text{Max.})$

PIN Connection

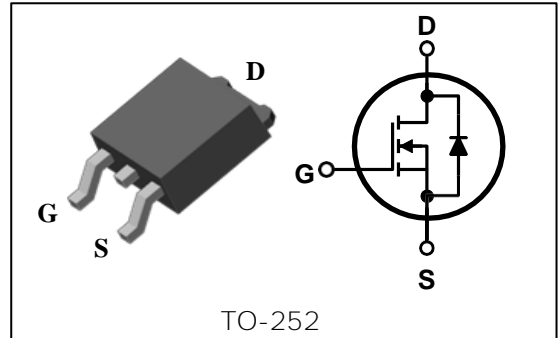

Ordering Information

Type No.	Marking	Package Code
MPVD4N65	MPVD4N65	TO-252

Absolute maximum ratings ($T_C=25^\circ\text{C}$ unless otherwise noted)

Characteristic	Symbol	Rating	Unit	
Drain-source voltage	V_{DSS}	650	V	
Gate-source voltage	V_{GSS}	± 30	V	
Drain current (DC) *	I_D	($T_C=25^\circ\text{C}$)	4.0	A
		($T_C=100^\circ\text{C}$)	2.5	A
Drain current (Pulsed) *	I_{DM}	16.0	A	
Power dissipation	P_D	80	W	
Avalanche current (Single) ②	I_{AS}	4.0	A	
Single pulsed avalanche energy ②	E_{AS}	240	mJ	
Avalanche current (Repetitive) ①	I_{AR}	4.0	A	
Repetitive avalanche energy ①	E_{AR}	10	mJ	
Junction temperature	T_J	150	°C	
Storage temperature range	T_{stg}	-55 ~ 150		

* Limited by maximum junction temperature

Characteristic	Symbol	Typ.	Max.	Unit
Thermal resistance	Junction-case	-	1.56	°C/W
	Junction-ambient	-	110	



MPVD4N65

Electrical Characteristics (T_C=25°C unless otherwise noted)

Characteristic	Symbol	Test Condition	Min.	Typ.	Max.	Unit	
Drain-source breakdown voltage	BV _{DSS}	I _D =250uA, V _{GS} =0	650	-	-	V	
Gate threshold voltage	V _{GS(th)}	I _D =250uA, V _{DS} =V _{GS}	2.0	-	4.0	V	
Drain-source cut-off current	I _{DSS}	V _{DS} =600V, V _{GS} =0	-	-	10	uA	
Gate leakage current	I _{GSS}	V _{DS} =0V, V _{GS} =±30V	-	-	±100	nA	
Drain-source on-resistance ④	R _{DS(on)}	V _{GS} =10V, I _D =3.25A		2.1	2.6	Ω	
Forward transfer conductance ④	g _{fs}	V _{DS} =10V, I _D =0.5A	-	0.8	-	S	
Input capacitance	C _{iss}	V _{GS} =0V, V _{DS} =25V, f=1MHz	-	710	920	pF	
Output capacitance	C _{oss}		-	65	85		
Reverse transfer capacitance	C _{rss}		-	14	19		
Turn-on delay time	t _{d(on)}	V _{DD} =300V, I _D =4.4A R _G =25Ω	-	20	50	ns	
Rise time	t _r		-	55	120		
Turn-off delay time	t _{d(off)}		③④	-	70		150
Fall time	t _f		-	50	120		
Total gate charge	Q _g	V _{DS} =400V, V _{GS} =10V I _D =4.4A	-	12		nC	
Gate-source charge	Q _{gs}		-	2.0			
Gate-drain charge	Q _{gd}		③④	-	5.0		-

Source-Drain Diode Ratings and Characteristics (T_C=25°C unless otherwise noted)

Characteristic	Symbol	Test Condition	Min.	Typ.	Max.	Unit
Source current (DC)	I _S	Integral reverse diode in the MOSFET			4	A
Source current (Pulsed) ①	I _{SM}				17.6	
Forward voltage ④	V _{SD}	V _{GS} =0V, I _S A=4.4A			1.4	V
Reverse recovery time	t _{rr}	I _S =4.4A, V _{GS} =0V dI _F /dt=100A/us	-	390	-	ns
Reverse recovery charge	Q _{rr}		-	2.2	-	uC

Note ;

- ① Repetitive rating : Pulse width limited by maximum junction temperature
- ② L=1080mH, I_{AS}=0.3A, V_{DD}=50V, R_G=25Ω, Starting T_J=25 °C
- ③ Pulse Test : Pulse width≤300us, Duty cycle≤2%
- ④ Essentially independent of operating temperature

Electrical Characteristic Curves

Fig. 1 $I_D - V_{DS}$

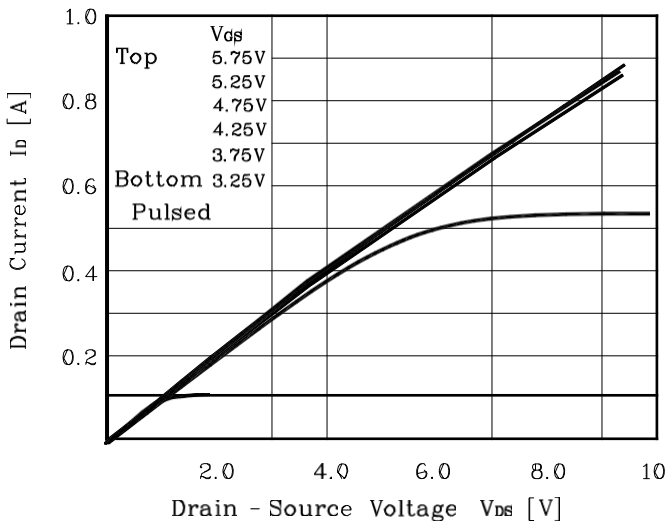

Fig. 2 $I_D - V_{GS}$

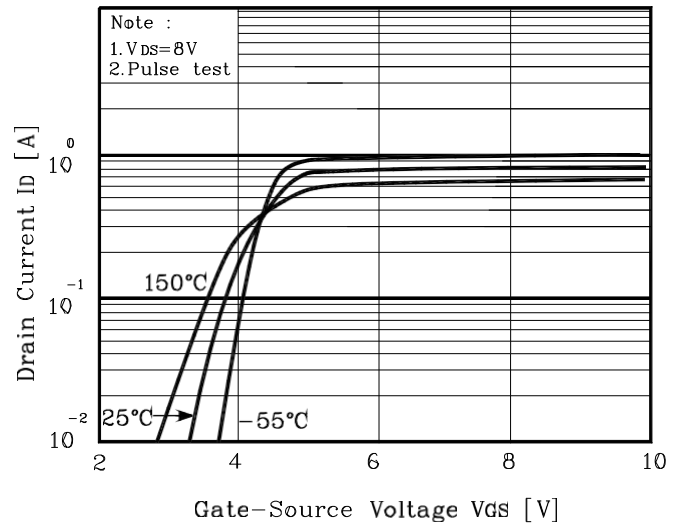

Fig. 3 $R_{DS(on)} - I_D$

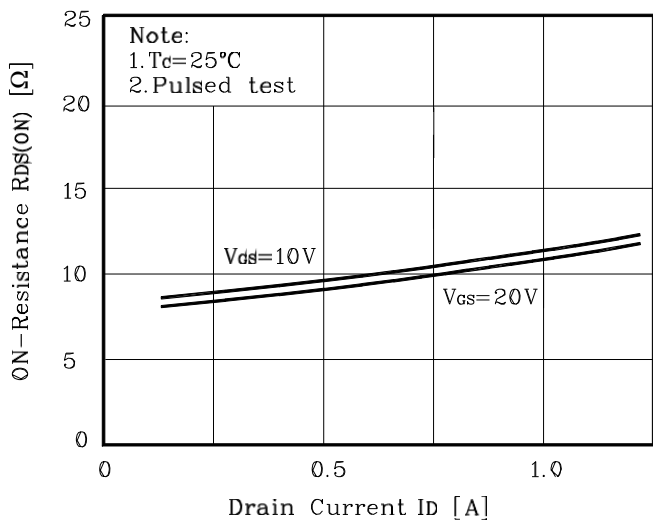

Fig. 4 $I_S - V_{SD}$

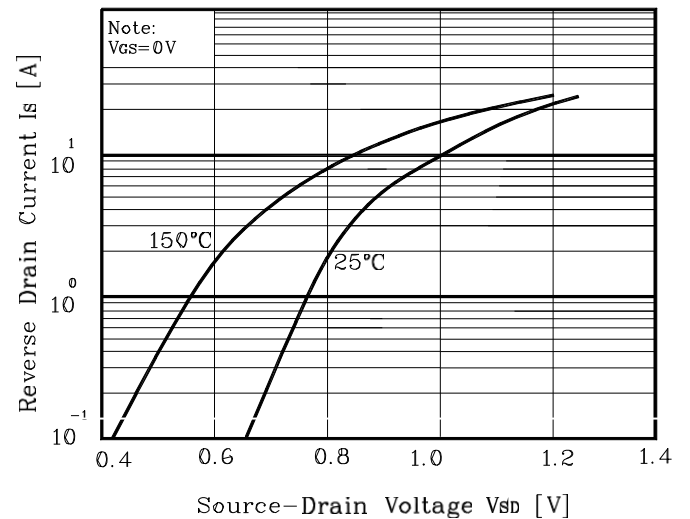

Fig. 5 Capacitance - V_{DS}

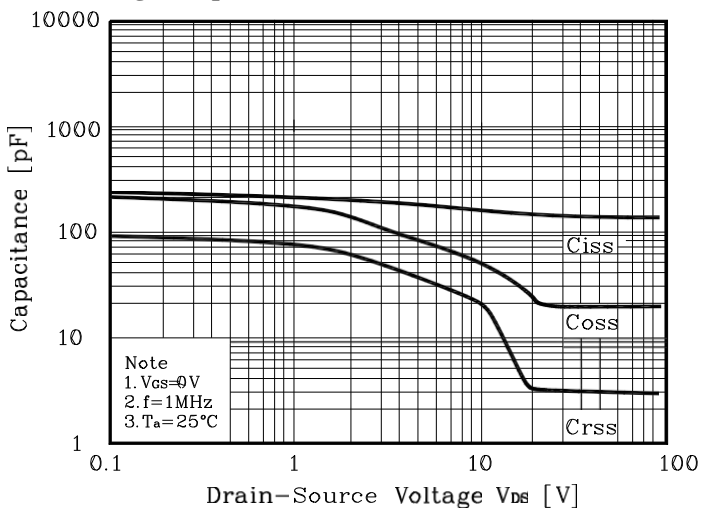
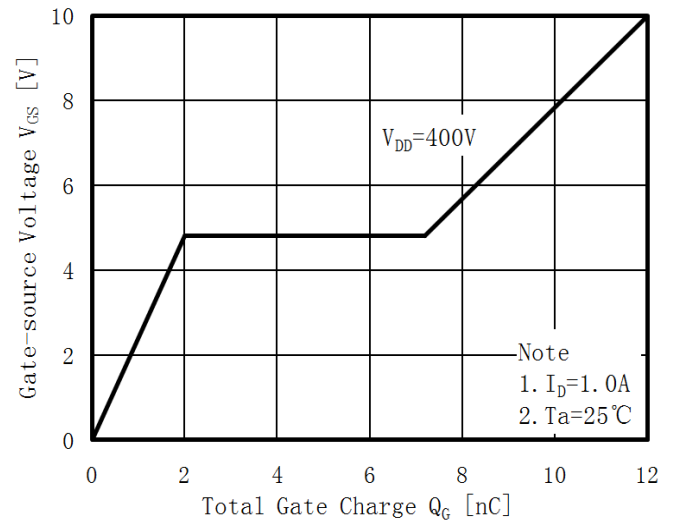

Fig. 6 $V_{GS} - Q_G$



Typical Characteristics(Con.)

Fig. 7 $V_{DSS} - T_J$

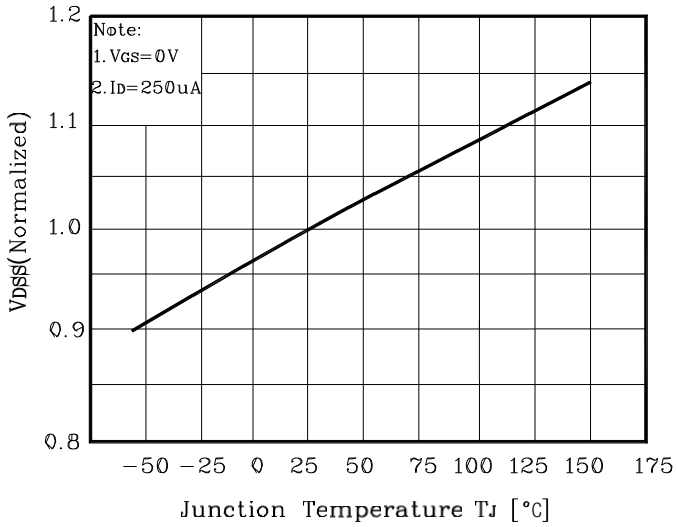

Fig. 8 $R_{DS(on)} - T_J$

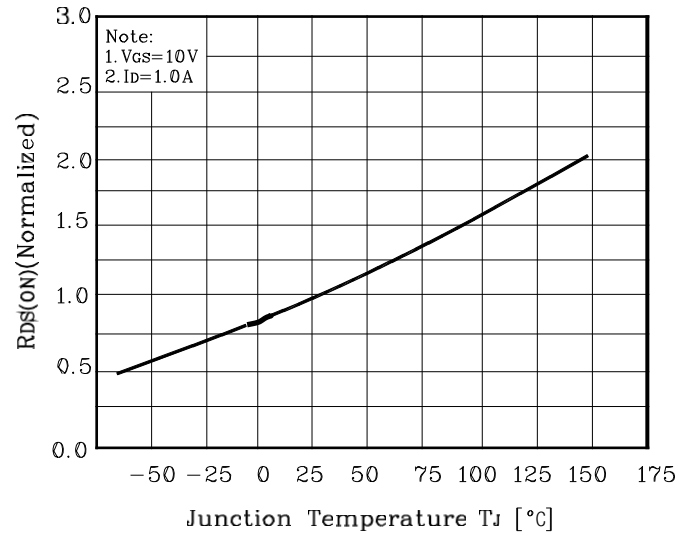

Fig. 9 $I_D - T_c$

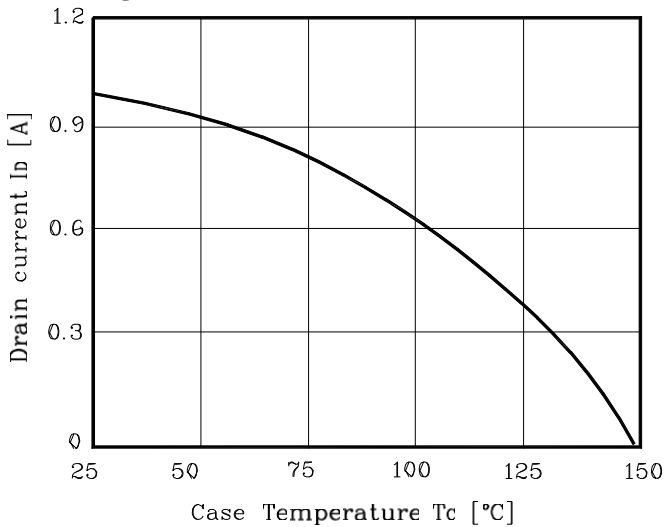

Figure 10. Safe Operating Area

(TO-251 TO-252)

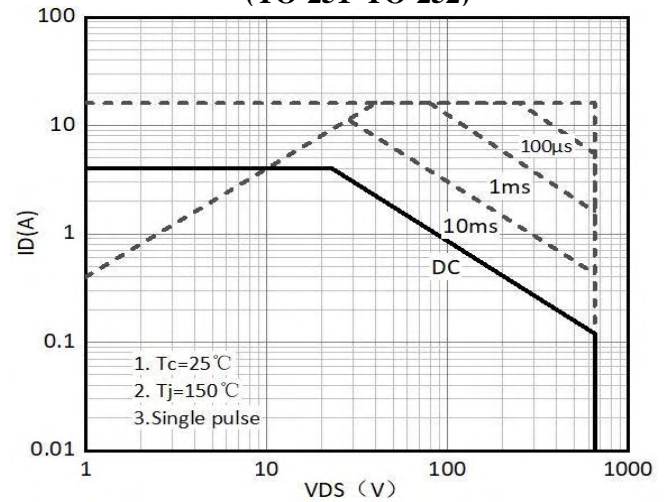

Fig. 11 Gate Charge Test Circuit & Waveform

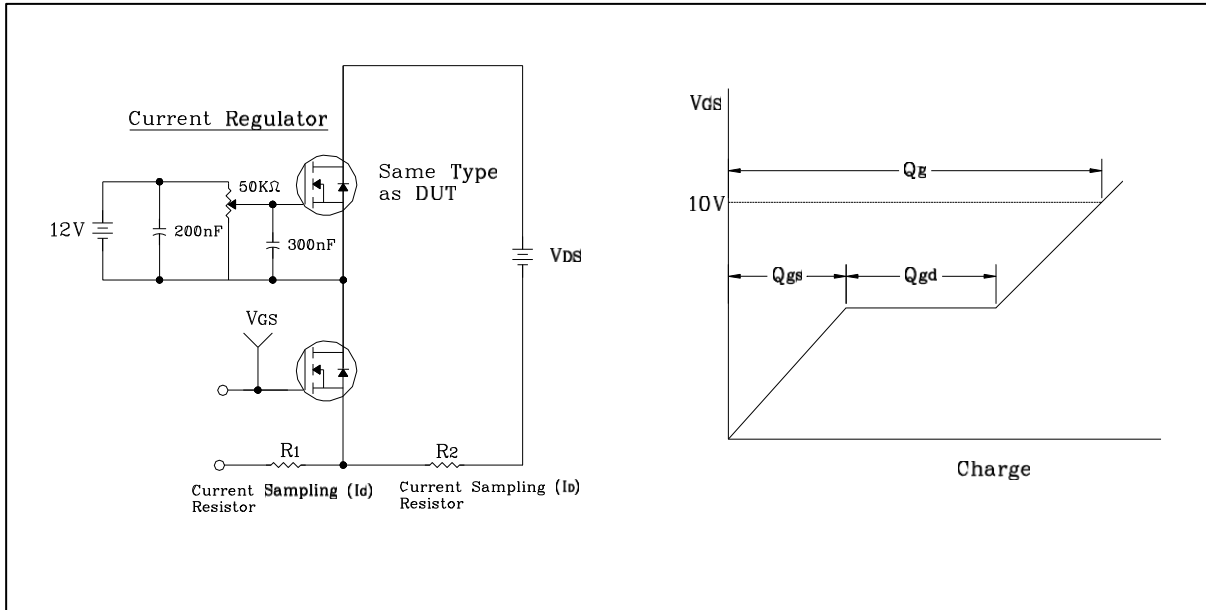

Fig. 12 Resistive Switching Test Circuit & Waveform

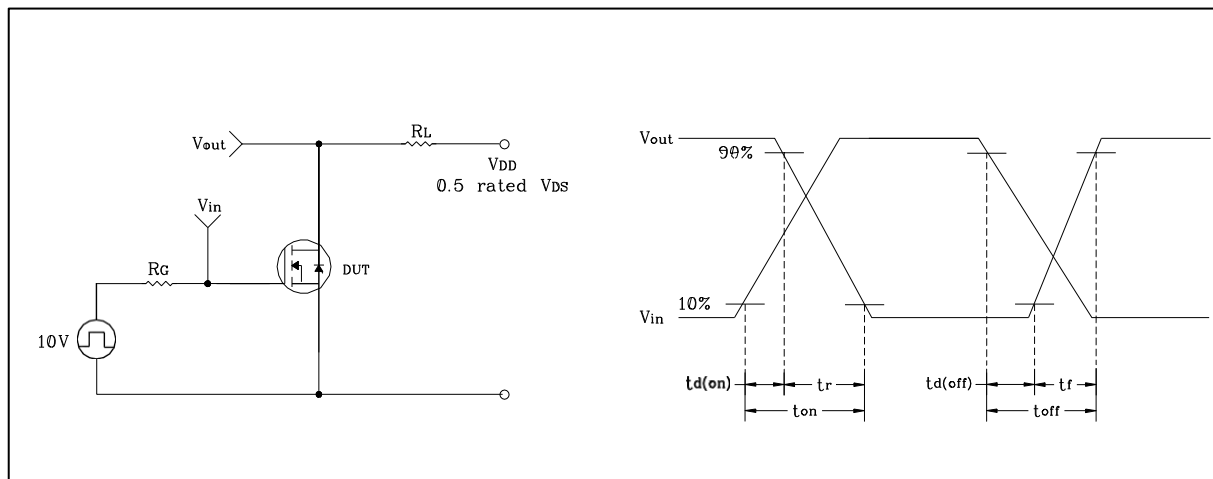

Fig. 13 EAS Test Circuit & Waveform

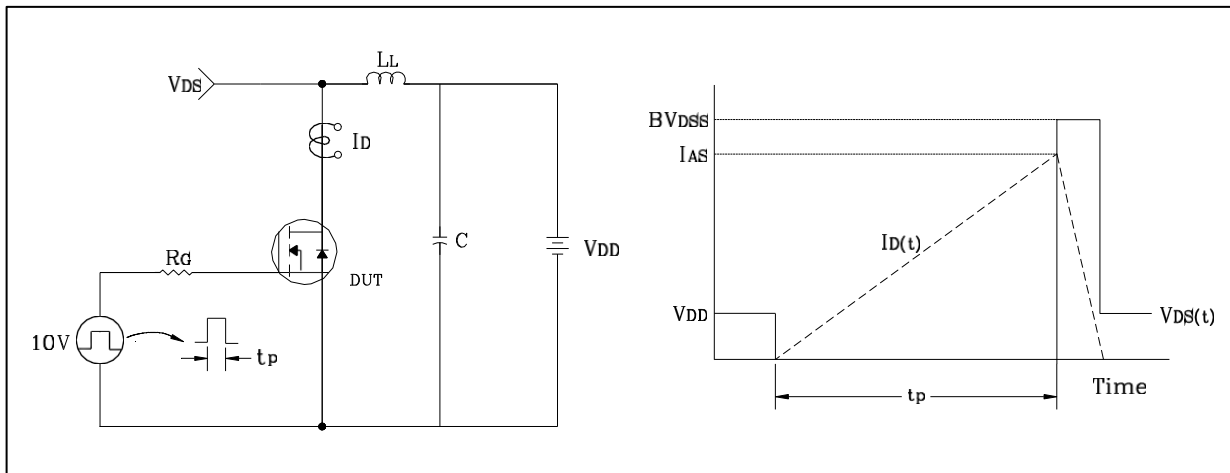
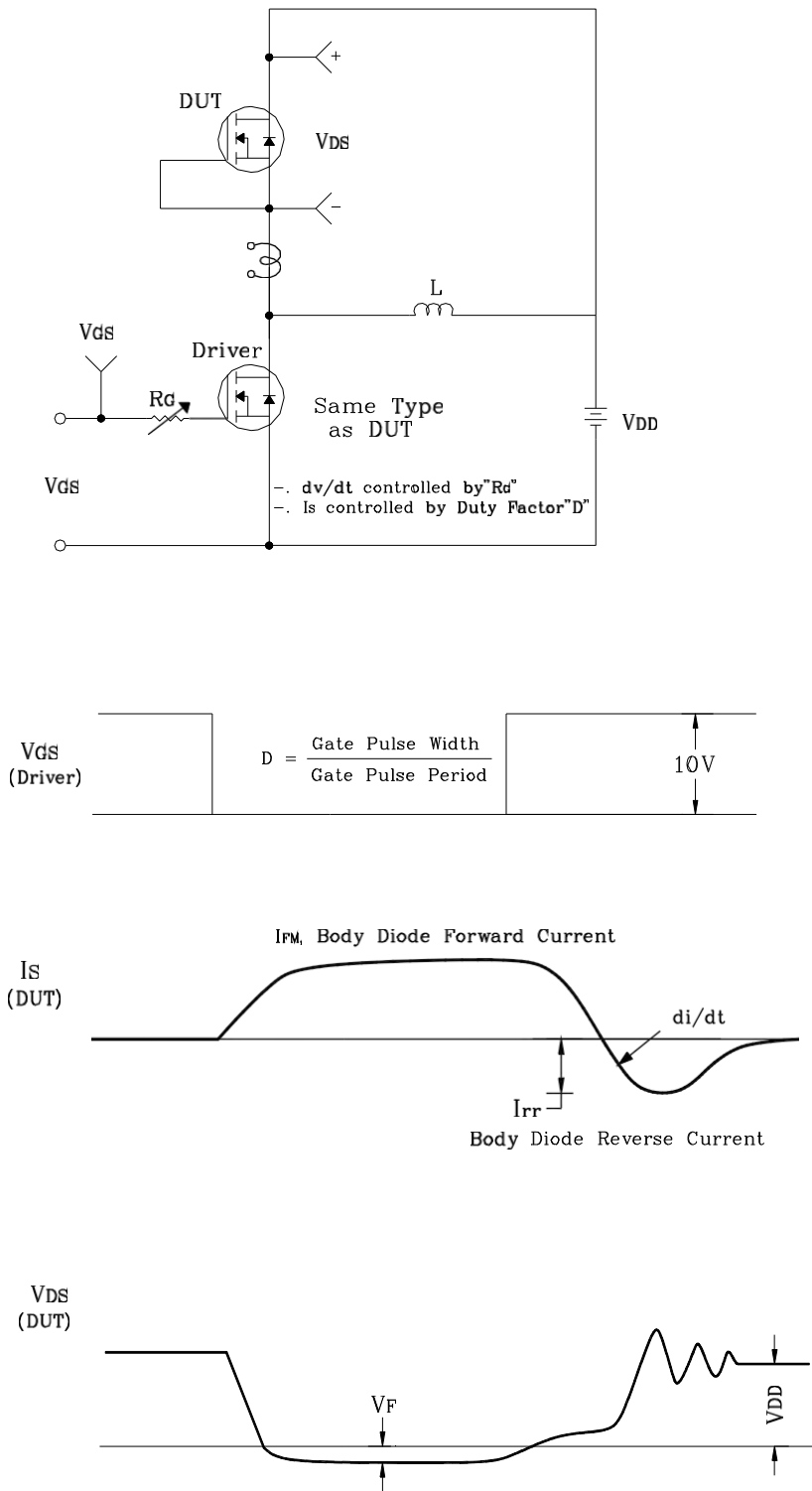

Fig. 14 Diode Reverse Recovery Time Test Circuit & Waveform





MPVD4N65

Outline Dimension

unit: mm

