

## 11Amps, 700Volts N-Channel Super Junction MOS-FET

### ■ Product Summary

$V_{DS} @ T_{j,max}$	700V
$R_{DS(on),max}$	0.36Ω
$I_{DM}$	30A
$Q_{g,typ}$	28nC

### ■ DESCRIPTION

FTK11NS70 Power MOS FET is fabricated using advanced super junction technology. The resulting device has extremely low on resistance, making it especially suitable for applications which require superior power density and outstanding efficiency.

### ■ FEATURES

- Ultra fast body diode
- Ultra low  $R_{DS(on)}$
- Ultra low gate charge (typ.  $Q_g = 28nC$ )
- 100% UIS tested
- RoHS compliant

### ■ SYMBOL

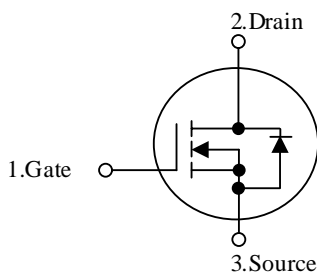

### ■ Applications

- Power factor correction (PFC)
- Switched mode power supplies (SMPS)
- Uninterruptible power supply (UPS)

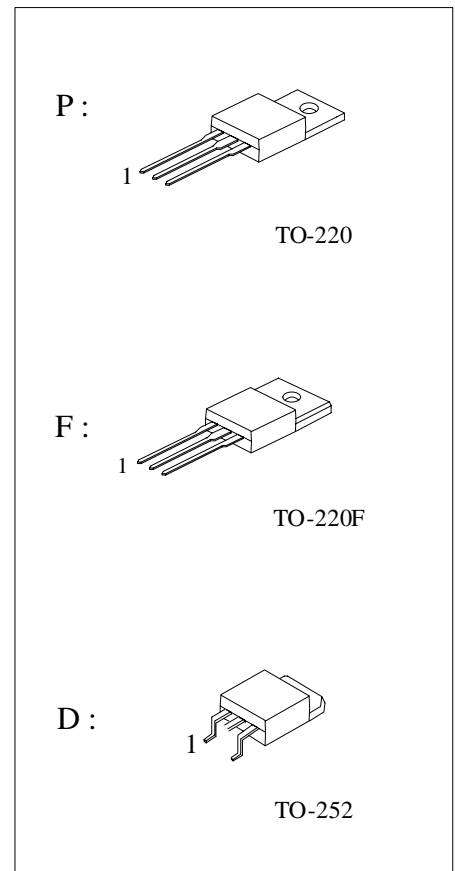

### ■ ORDERING INFORMATION

Order Number	Package	Pin Assignment			Packing
		1	2	3	
FTK11NS70P	TO-220	G	D	S	Tube
FTK11NS70F	TO-220F	G	D	S	Tube
FTK11NS70D	TO-252	G	D	S	Tube

Note. Pin Assignmen G: Gate D: Drain S: Source



# FTK11NS70P/F/D

## Absolute Maximum Ratings

Parameter	Symbol	Value	Unit
Drain - Source Voltage	$V_{DSS}$	700	V
Continuous drain current ( $T_c = 25^\circ\text{C}$ )	$I_D$	11	A
( $T_c = 100^\circ\text{C}$ )		7	A
Pulsed drain current <sup>1)</sup>	$I_{DM}$	30	A
Gate - Source voltage	$V_{GSS}$	$\pm 30$	V
Avalanche energy, single pulse <sup>2)</sup>	$E_{AS}$	350	mJ
Avalanche energy, repetitive <sup>1)</sup>	$E_{AR}$	12.5	mJ
Avalanche current, repetitive <sup>1)</sup>	$I_{AR}$	11	A
Power Dissipation ( $T_c = 25^\circ\text{C}$ )	$P_D$	83	W
- Derate above $25^\circ\text{C}$		0.67	W/ $^\circ\text{C}$
Operating and Storage Temperature Range	$T_J, T_{STG}$	-55 to +150	$^\circ\text{C}$
Continuous diode forward current	$I_S$	11	A
Diode pulse current	$I_{S,pulse}$	30	A

## Thermal Characteristics TO-220/TO-252

Parameter	Symbol	Value	Unit
Thermal Resistance, Junction-to-Case	$R_{\theta JC}$	2.5	$^\circ\text{C/W}$
Thermal Resistance, Junction-to-Ambient	$R_{\theta JA}$	62	$^\circ\text{C/W}$

## Thermal Characteristics TO-220F

Parameter	Symbol	Value	Unit
Thermal Resistance, Junction-to-Case	$R_{\theta JC}$	4.3	$^\circ\text{C/W}$
Thermal Resistance, Junction-to-Ambient	$R_{\theta JA}$	80	$^\circ\text{C/W}$



# FTK11NS70P/F/D

## Electrical Characteristics (T<sub>c</sub> = 25°C unless otherwise noted)

Parameter	Symbol	Test Condition	Min.	Typ.	Max.	Unit
<b>Static characteristics</b>						
Drain-source breakdown voltage	BV <sub>DSS</sub>	V <sub>GS</sub> =0 V, I <sub>D</sub> =0.25 mA	700	-	-	V
Gate threshold voltage	V <sub>GS(th)</sub>	V <sub>DS</sub> =V <sub>GS</sub> , I <sub>D</sub> =0.25mA	2.0	-	4.0	V
Drain cut-off current	I <sub>DSS</sub>	V <sub>DS</sub> =700 V, V <sub>GS</sub> =0 V,	-	-	1	μA
Gate leakage current, Forward	I <sub>GSSF</sub>	V <sub>GS</sub> =30 V, V <sub>DS</sub> =0 V	-	-	100	nA
Gate leakage current, Reverse	I <sub>GSSR</sub>	V <sub>GS</sub> =-30 V, V <sub>DS</sub> =0 V	-	-	-100	nA
Drain -source on-state resistance	R <sub>DS(on)</sub>	V <sub>GS</sub> =10 V, I <sub>D</sub> =5.5A	-	-	-	-
		T <sub>j</sub> = 25°C	-	0.31	0.36	Ω
		T <sub>j</sub> = 150°C	-	0.69	-	-
Gate resistance	R <sub>G</sub>	f=1 MHz, open drain	-	0.9	-	Ω
<b>Dynamic characteristics</b>						
Input capacitance	C <sub>iss</sub>	V <sub>DS</sub> = 25 V, V <sub>GS</sub> = 0 V, f = 1 MHz	-	1040	-	pF
Output capacitance	C <sub>oss</sub>		-	780	-	
Reverse transfer capacitance	C <sub>rss</sub>		-	10	-	
Turn-on delay time	t <sub>d(on)</sub>	V <sub>DD</sub> = 380V, I <sub>D</sub> = 5.5A R <sub>G</sub> = 4.7Ω, V <sub>GS</sub> =10V	-	16	-	ns
Rise time	t <sub>r</sub>		-	14	-	
Turn-off delay time	t <sub>d(off)</sub>		-	40	-	
Fall time	t <sub>f</sub>		-	5	-	
<b>Gate charge characteristics</b>						
Gate to source charge	Q <sub>gs</sub>	V <sub>DD</sub> =480 V, I <sub>D</sub> =5.5A, V <sub>GS</sub> =0 to 10 V	-	6	-	nC
Gate to drain charge	Q <sub>gd</sub>		-	13	-	
Gate charge total	Q <sub>g</sub>		-	28	-	
Gate plateau voltage	V <sub>plateau</sub>		-	5.5	-	V
<b>Reverse diode characteristics</b>						
Diode forward voltage	V <sub>SD</sub>	V <sub>GS</sub> =0 V, I <sub>F</sub> =5.5A	-	-	1.4	V
Reverse recovery time	t <sub>rr</sub>	V <sub>R</sub> =50 V, I <sub>F</sub> =11A, dI <sub>F</sub> /dt=100 A/μs	-	430	-	ns
Reverse recovery charge	Q <sub>rr</sub>		-	3.6	-	μC
Peak reverse recovery current	I <sub>rrm</sub>		-	15	-	A

### Notes:

1. Repetitive Rating: Pulse width limited by maximum junction temperature
2. I<sub>AS</sub> = 3.5A, V<sub>DD</sub> = 60V, R<sub>G</sub> = 25Ω, Starting T<sub>J</sub> = 25°C

## Typical Characteristics

Figure 1. On-Region Characteristics

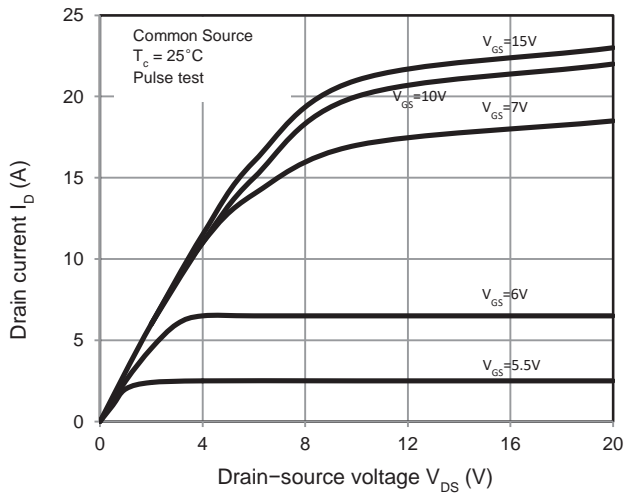

Figure 2. Transfer Characteristics

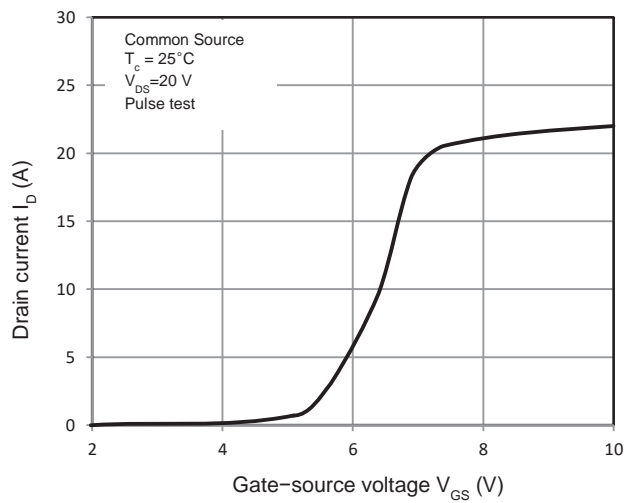

Figure 3. On-Resistance Variation vs. Drain Current

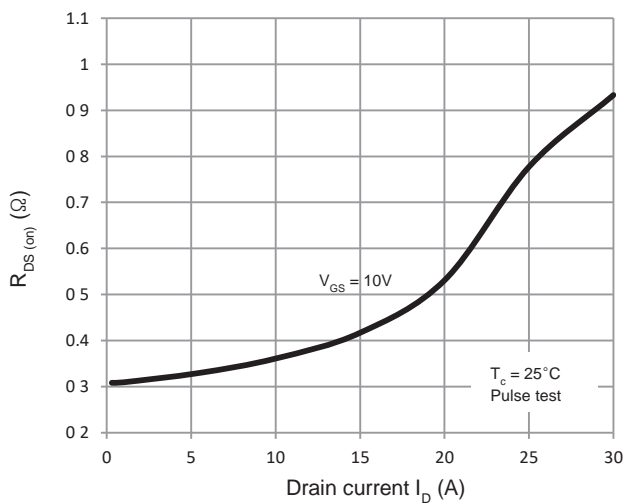

Figure 4. Threshold Voltage vs. Temperature

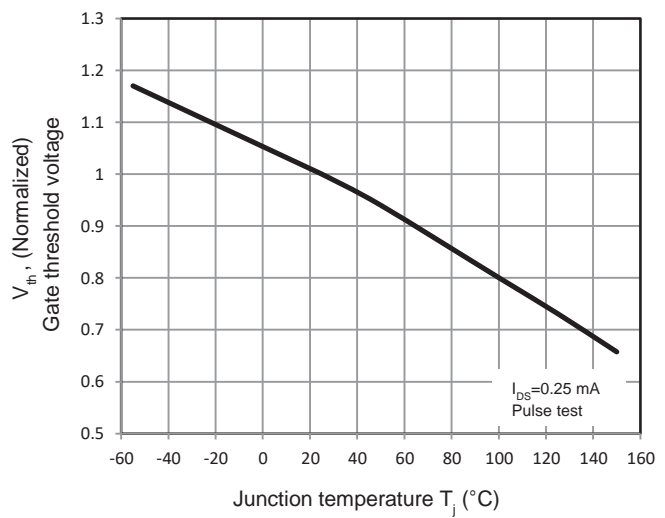

Figure 5. Breakdown Voltage vs. Temperature

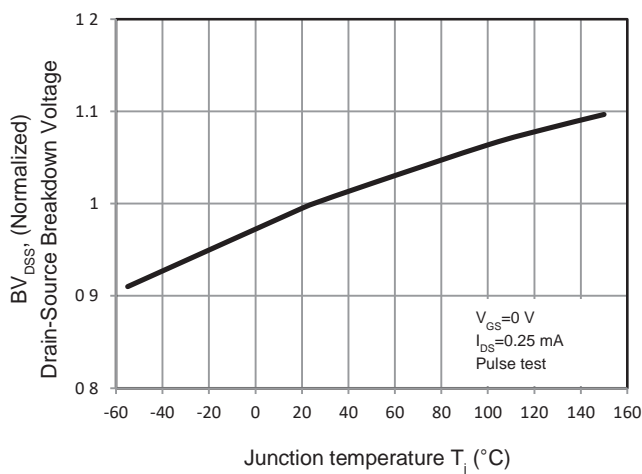

Figure 6. On-Resistance vs. Temperature

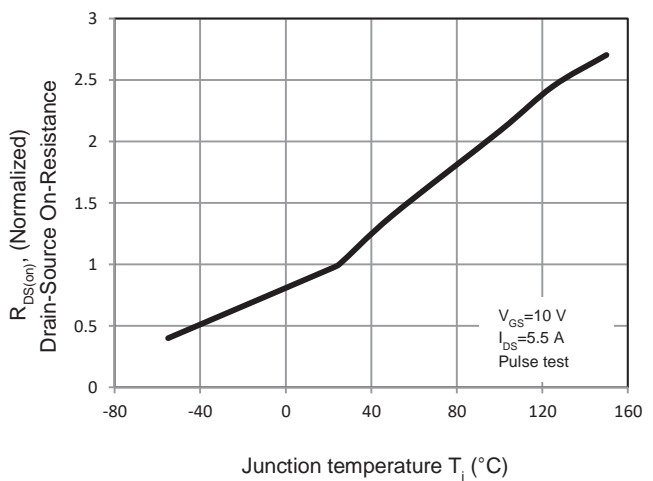

Figure 7. Capacitance Characteristics

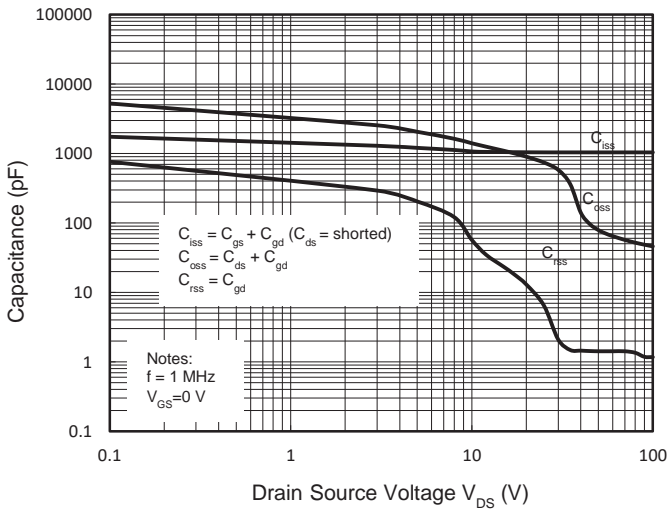

Figure 8. Gate Charge Characteristics

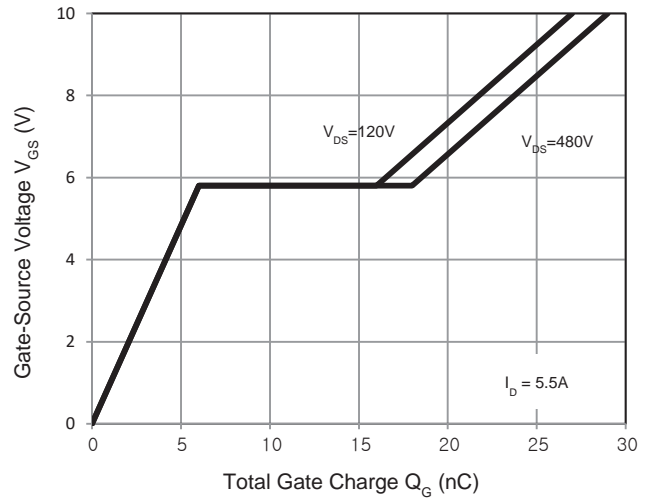

Figure 9. Maximum Safe Operating Area

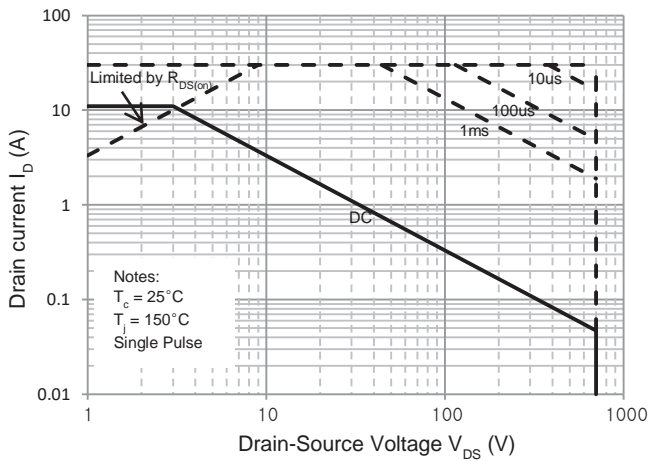

Figure 10. Power Dissipation vs. Temperature

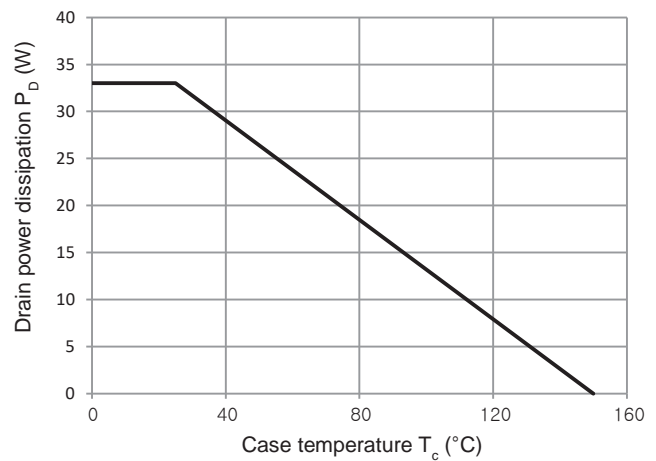
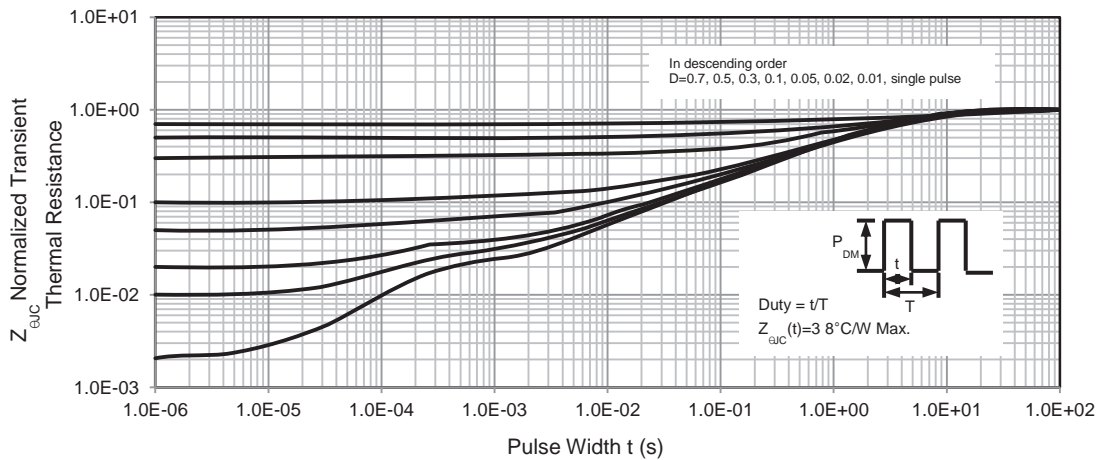

Figure 11. Transient Thermal Response Curve



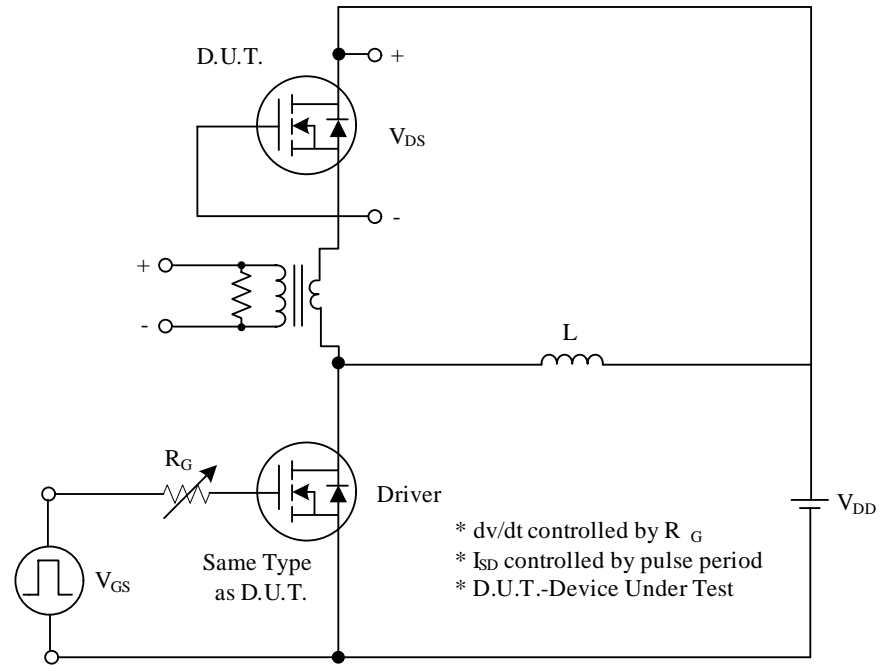

Fig. 1A Peak Diode Recovery dv/dt Test Circuit

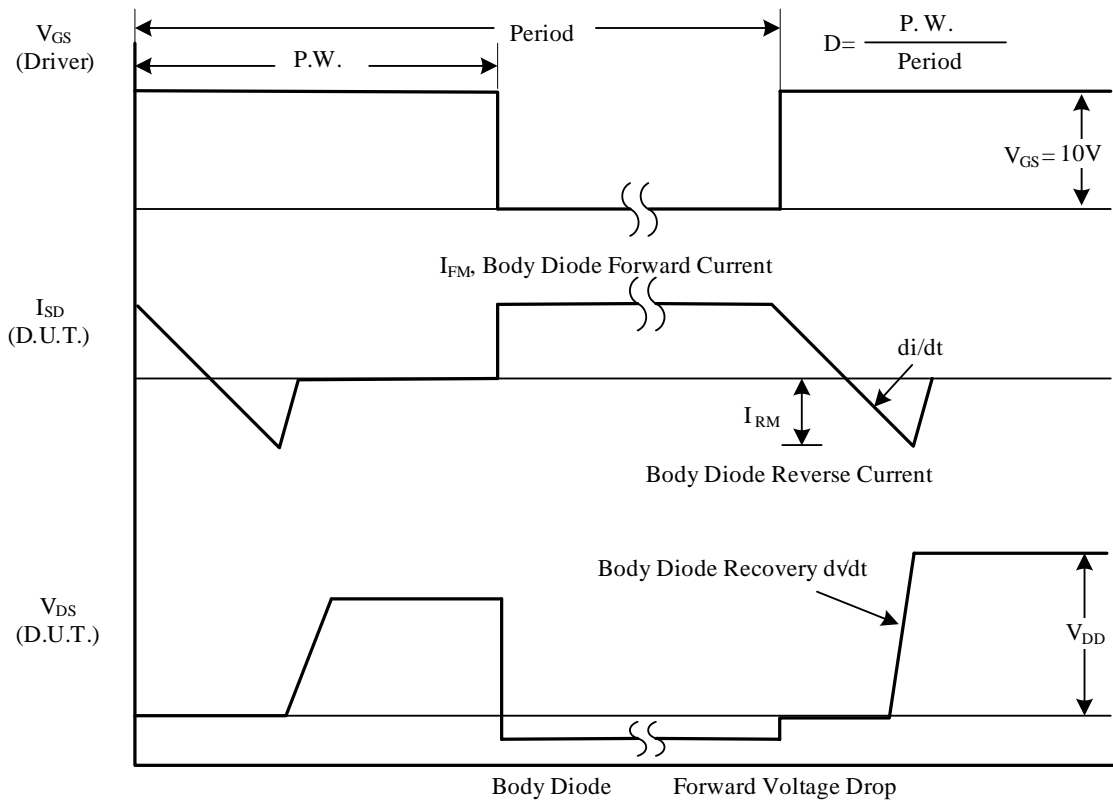

Fig. 1B Peak Diode Recovery dv/dt Waveforms

## ■ TEST CIRCUITS AND WAVEFORMS (Cont.)

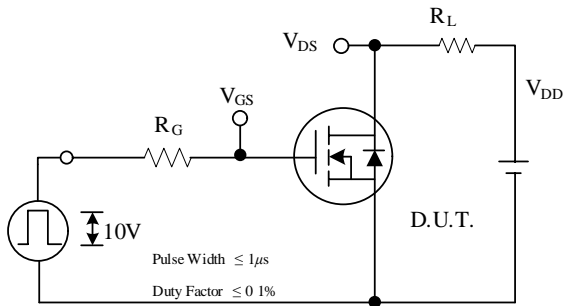

Fig. 2A Switching Test Circuit

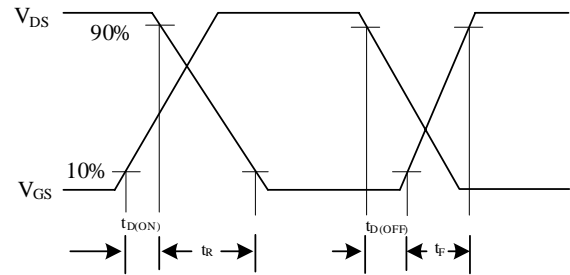

Fig. 2B Switching Waveforms

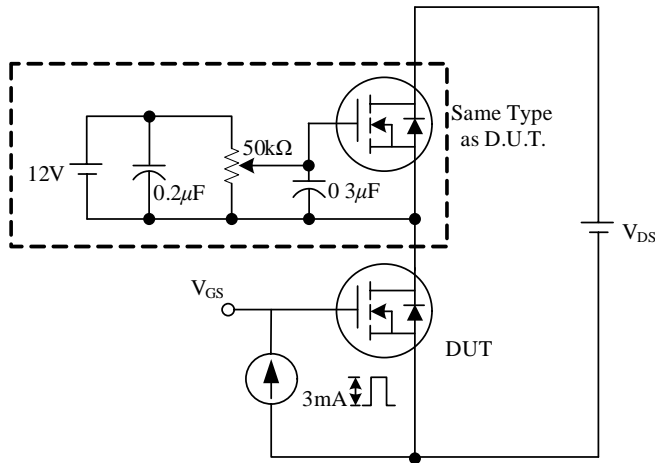

Fig. 3A Gate Charge Test Circuit

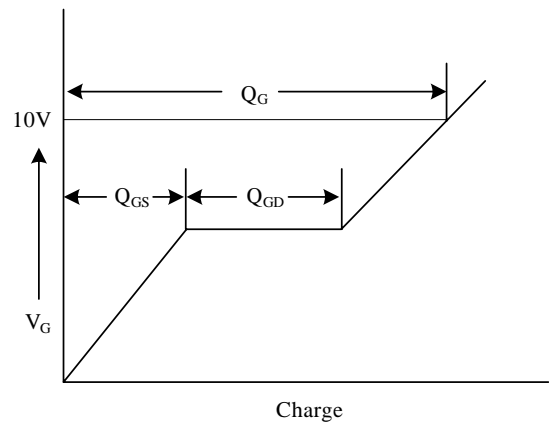

Fig. 3B Gate Charge Waveform

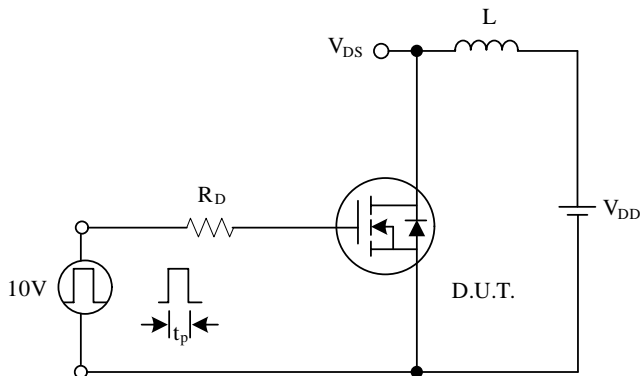

Fig. 4A Unclamped Inductive Switching Test Circuit

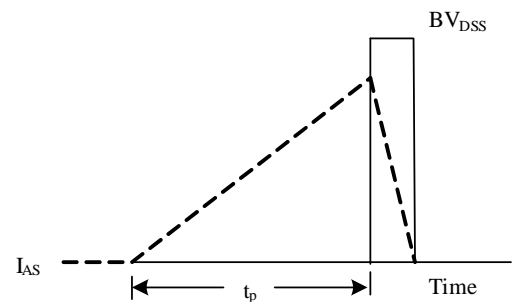

Fig. 4B Unclamped Inductive Switching Waveforms