



Dual Schottky Barrier Rectifiers

Reverse Voltage 60 Volts Forward Current 30.0 Amperes

Features

- ◆ Plastic package has Underwriters Laboratory Flammability Classification 94V-0
- ◆ Dual rectifier construction, positive center tap
- ◆ Metal silicon junction, majority carrier conduction
- ◆ Low power loss, high efficiency
- ◆ Guardring for overvoltage protection
- ◆ For use in low voltage, high frequency inverters, free wheeling, and polarity protection applications
- ◆ High temperature soldering guaranteed:
250°C/10 seconds, 0.25" (6.35mm) from case

Mechanical Data

- ◆ Case: JEDEC TO-220AB, TO-220F, TO-263AB molded plastic body
- ◆ Terminals: Plated leads, solderable per MIL-STD-750, Method 2026
- ◆ Polarity: As marked
- ◆ Mounting Position: Any
- ◆ Mounting Torque: 10 in-lbs maximum
- ◆ Weight: 0.08 ounce, 2.24 grams

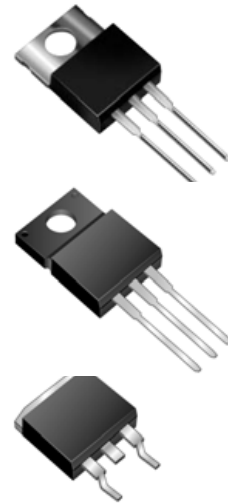

TO-220AB

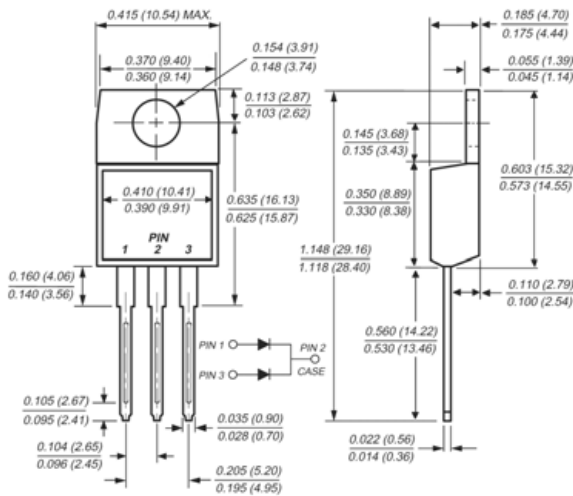

TO-220F

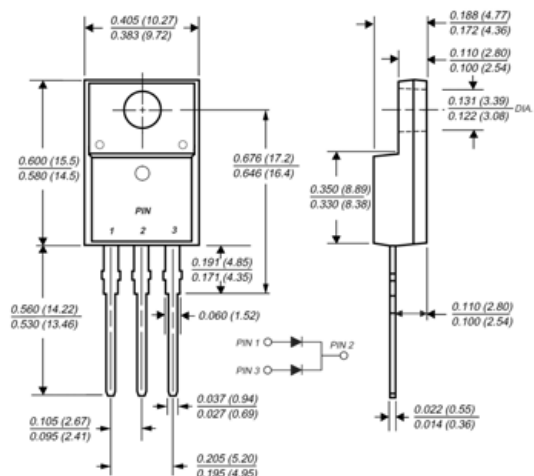

TO-263AB(D²PAK)

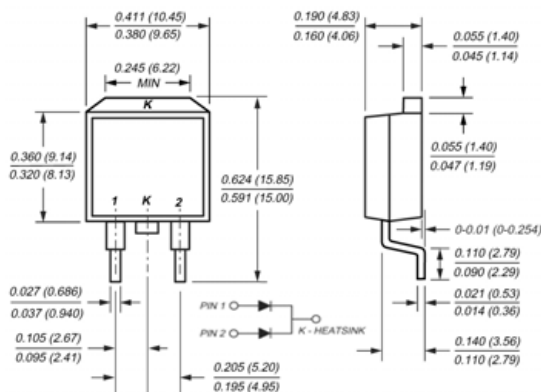

Mounting Pad Layout TO-263AB

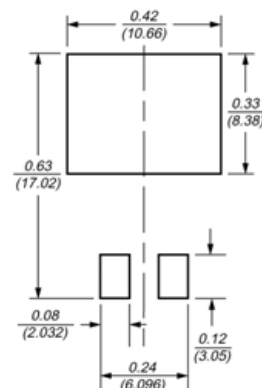

Dimensions in inches and (millimeters)



Maximum Ratings and Electrical Characteristics

(T_C = 25°C unless otherwise noted)

MAXIMUM RATINGS and ELECTRICAL CHARACTERISTICS(TC=25°C unless otherwise moted)					
PARAMETER	TEST CONDITIONS		SYMBOL	MBRF3060CT	UNIT
Maximum repetitive peak reverse voltage			VRRM	60	V
Working peak reverse voltage			VRWM	60	V
Maximum DC blocking voltage			VDC	60	V
Maximum average forward rectified current at Tc=105°C total device per diode			IF(AV)	30 15	A
Peak forward surge current 8.3ms single half sine-wave superimposed on rated load per diode			IFSM	200	A
Peak repetitive reverse current per leg at tp=2.0us , 1KHz			IRRM	1.0	A
Voltage rate of change (rated VR)			DV/dt	10000	V/us
Operating junction temperature range			TJ	-55 to +150	°C
Storage temperature range			TSTG	-55 to +150	°C
Isolation voltage (ITO-220 only) from terminal to heatsink t = 1 sec			VAC	1500	V
Maximum instantaneous forward voltage per leg	IF=15A IF=15A	Tc=25°C Tc=125°C	VF	0.85 0.75	V
Maximum reverse current per leg at working peak Reverse voltage			IR	0.5 40	mA

Thermal Characteristics Ta=25°C unless otherwise noted

Symbol	Parameter	Max	Unit
RθJC	Thermal Resistance, Junction to Case per Leg	4.0	°C/W
RθJA	Thermal Resistance, Junction to Ambient per legs	62.5	°C/W

Note:

1. Screw mounting with 4-40 screw, where washer diameter is ≤4.9mm(0.19 ")
2. Pulse test: 300us pulse width, 1% duty cycle



Rating and Characteristic Curves

