

Features

- Ultra small package: 0.6x0.3x0.3mm
- Ultra low capacitance:0.28pF typical
- Ultra low leakage: nA level
- Low operating voltage: $\pm 5V$
- Low clamping voltage
- 2-pin leadless package
- Complies with following standards:
 - IEC 61000-4-2 (ESD) immunity test
Air discharge: $\pm 30kV$
Contact discharge: $\pm 25kV$
 - IEC61000-4-5 (Lightning)4A (8/20 μs)
- RoHS Compliant
- Lead Finish: NiPdAu

Mechanical Characteristics

- Package: DFN0603-2(0201)
- Lead Finish: Matte Tin
- Case Material: “Green” Molding Compound.
- Moisture Sensitivity: Level 3 per J-STD -020
- Terminal Connections: See Diagram Below
- Shipping Qty :15000pcs Or 10000/7Inch Tape & Reel

Applications

- Cellular Handsets & Accessories
- Digital Visual Interface (DVI)
- Display Port
- MDDI Ports
- USB Ports

Dimensions and Pin Configuration

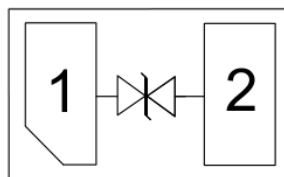



FESD5V0B03-0201

Absolute Maximum Ratings (Tamb=25°C unless otherwise specified)

Parameter	Symbol	Value	Unit
Peak Pulse Power (8/20µs)	Ppk	70	W
Peak Pulse Current (8/20µs)	Ipp	4	A
ESD per IEC 61000-4-2 (Air)	VESD	±30	kV
ESD per IEC 61000-4-2 (Contact)		±30	
Operating Temperature Range	TJ	-55 to +125	°C
Storage Temperature Range	Tstg	-55 to +150	°C

Electrical Characteristics (TA=25°C unless otherwise specified)

Parameter	Symbol	Min	Typ	Max	Unit	Test Condition
Reverse Working Voltage	VRWM			5	V	
Breakdown Voltage	VBR	6.5	7.5	9.0	V	IT = 1mA
Reverse Leakage Current	IR			0.08	µA	VRWM = 5V
Clamping Voltage	VC			14	V	Ipp=1A(8x 20us pulse)
	VC		16	20	V	Ipp=4A(8x 20us pulse)
Junction Capacitance	CJ		0.28		pF	VR = 0V, f = 1MHz Pin1 to Pin2

Typical Performance Characteristics (TA=25°C unless otherwise Specified)

Fig1. 8/20µs Pulse Waveform

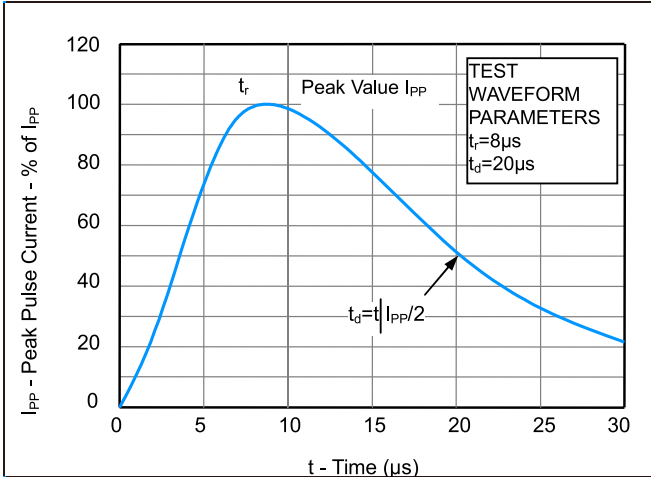

Fig2. ESD Pulse Waveform (according to IEC 61000-4-2)

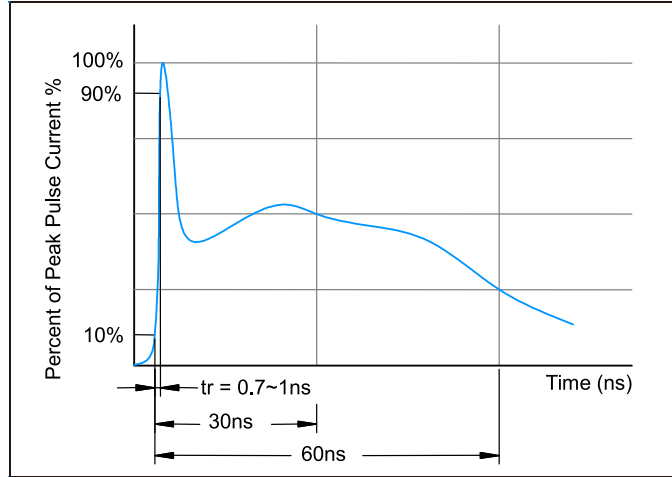
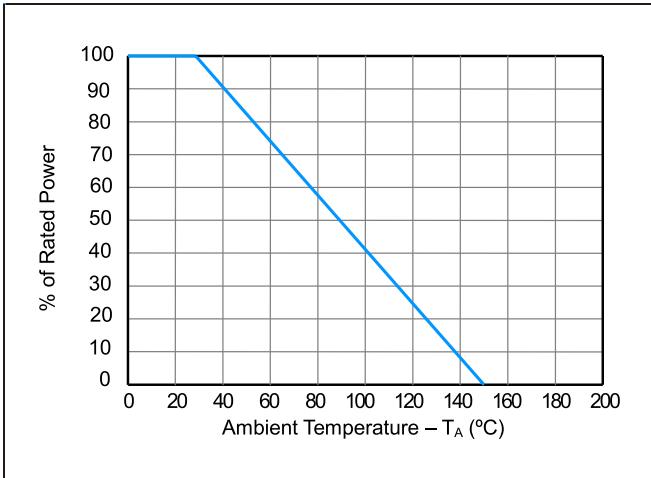
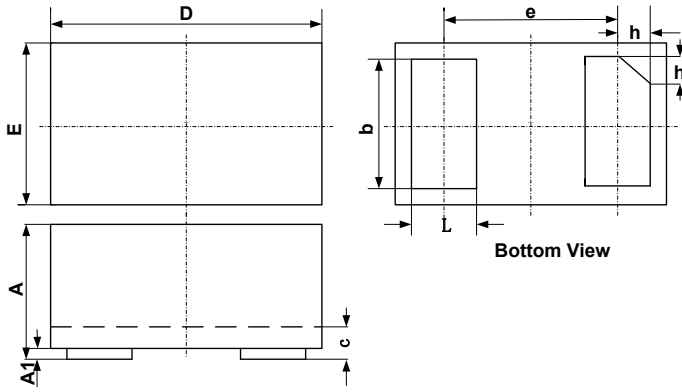

Fig3. Power Derating Curve



DFN0603-2 Package Outline Drawing (0201)



SYM	DIMENSIONS		
	MILLIMETERS		
	MIN	NOM	MAX
A	0.230	0.300	0.330
A1	0.000	0.020	0.050
b	0.215	0.245	0.275
c	0.120	0.150	0.180
D	0.550	0.600	0.650
e	0.355 BSC		
E	0.250	0.300	0.350
L	0.160	0.190	0.220
h	0.079 BSC		

Suggested Land Pattern

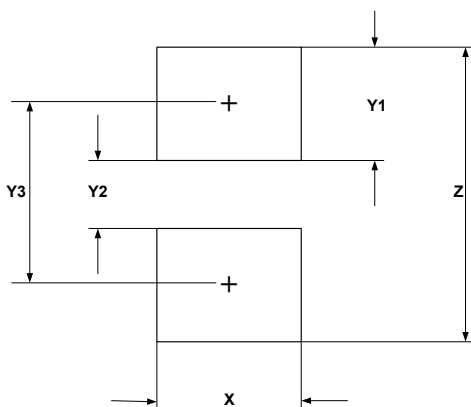

SYM	DIMENSIONS	
	MILLIMETERS	INCHES
X	0.30	0.012
Y1	0.25	0.010
Y2	0.15	0.006
Y3	0.40	0.016
Z	0.65	0.026