

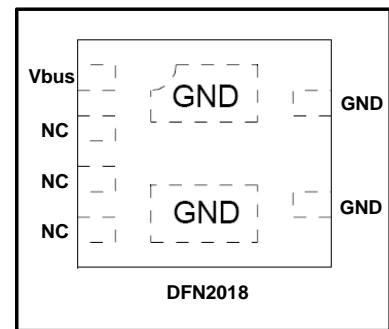
## 1 Line Uni directional TVS Diode

The FTV2018H12 is an uni-directional TVS diode, utilizing leading monolithic silicon technology to provide fast response time and low ESD clamping voltage, making this device an ideal solution for protecting voltage sensitive data and power line. The FTV2018H12 complies with the IEC 61000-4-2 (ESD) standard with  $\pm 30\text{kV}$  air and  $\pm 30\text{kV}$  contact discharge. The high ESD surge protection make FTV2018H12 an ideal choice to protect cell phone, digital cameras, audio players and many other portable applications.



### Features

- Protects one data or power line
- Low clamping voltage
- Complies with following standards:
  - IEC 61000-4-2 (ESD) immunity test
    - Air discharge:  $\pm 30\text{kV}$
    - Contact discharge:  $\pm 30\text{kV}$
- We declare that the material of product compliance with RoHS requirements and Halogen Free.



### Ordering information

Device	Marking	Shipping
FTV2018H12	12	3000/Tape&Reel

### Applications

- Mobile Phones
- Battery Protection
- Power Line Protection
- Vbus pin for Mobile Devices
- Hand Held Portable Applications



# FTV2018H12

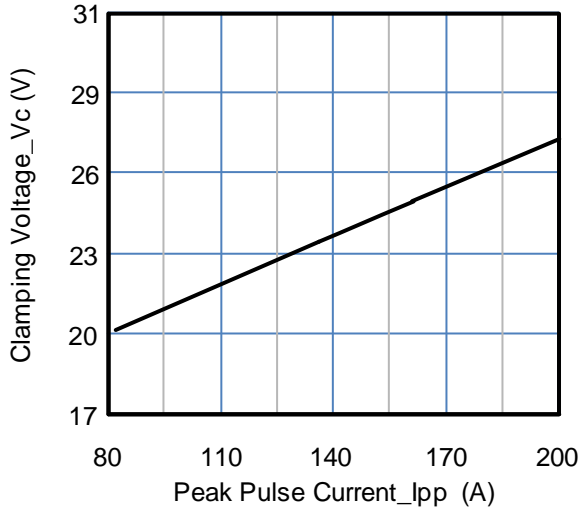
## Absolute Maximum Ratings ( $T_A = 25^\circ\text{C}$ unless otherwise specified)

Parameter	Symbol	Value	Unit
Peak Pulse Power (8/20 $\mu\text{s}$ )	Ppk	4000	W
Peak Pulse Current (8/20 $\mu\text{s}$ )	Ipp	180	A
ESD per IEC 61000-4-2 (Air)	VESD	$\pm 30$	kV
ESD per IEC 61000-4-2 (Contact)		$\pm 30$	
Operating Temperature Range	TJ	-55 to +125	$^\circ\text{C}$
Storage Temperature Range	Tstg	-55 to +150	$^\circ\text{C}$

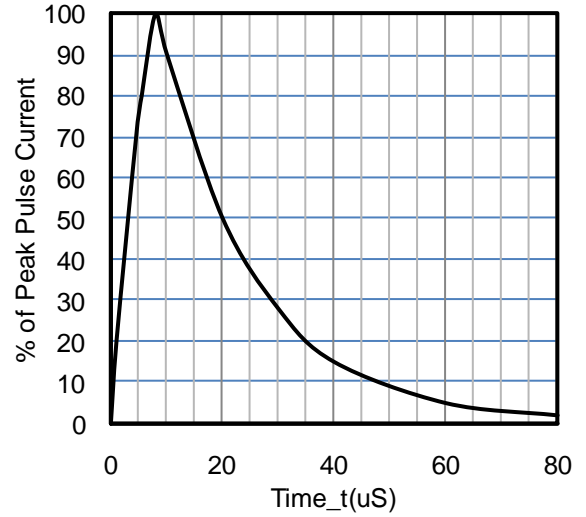
## Electrical Characteristics ( $T_A = 25^\circ\text{C}$ unless otherwise specified)

Parameter	Symbol	Min	Typ	Max	Unit	Test Condition
Reverse Working Voltage	VRWM			13.5	V	
Breakdown Voltage	VBR	14		17.5	V	IT = 1mA
Reverse Leakage Current	IR			500	nA	VR = 13.5V
Forward Voltage	VF		0.75	1.2	V	IF = 10mA
Clamping Voltage	VC		21	25	V	Ipp = 100A (8 x 20 $\mu\text{s}$ pulse)
Junction Capacitance	CJ		1000		pF	VR = 0V, f = 1MHz

## Typical Performance Characteristics ( $T_A=25^\circ\text{C}$ unless otherwise Specified)

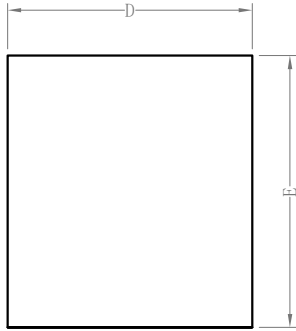


**Fig 1 .Clamping Voltage vs. Peak Pulse Current**

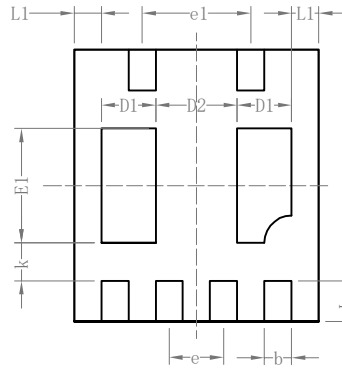


**Fig 2. 8 X 20uS Pulse Waveform**

## DFN2018

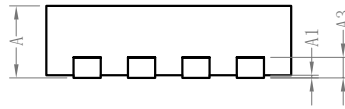


Top View



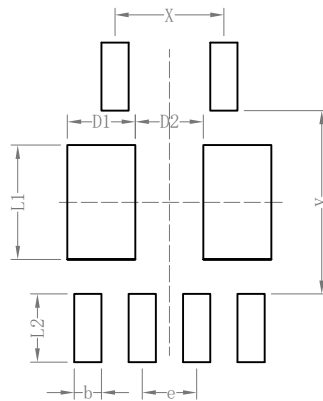
Bottom View

DFN2018			
Dim	Min.	Typ.	Max.
A	0.48	0.53	0.58
A1	0.00	0.02	0.05
A3	0.152REF.		
D	1.75	1.80	1.85
E	1.95	2.00	2.05
D1	0.35	0.40	0.45
E1	0.79	0.84	0.89
D2	0.55	0.60	0.65
b	0.15	0.20	0.25
e	0.40TYP.		
e1	0.80TYP.		
k	0.20MIN.		
L	0.25	0.30	0.35
L1	0.15	0.20	0.25
All Dimensions in mm			



Side View

### Suggested solder pad layout



DFN2018	
Dim	(mm)
X	0.80
Y	1.35
L1	0.840
L2	0.50
D1	0.50
D2	0.50
b	0.20
e	0.40