

### 1-CHANNEL TRANSISTOR OUTPUT TYPE PHOTO COUPLER

The PC817 Series contains a light emitting diode optically coupled to a phototransistor. Input-output isolation voltage is 5000Vrms. Response time( $t_r$ ) is typically 4 $\mu$ s and minimum CTR is 50% at input current of 5mA.

#### FEATURES

- Collector-Emitter Voltage : Min.80V
- Current Transfer Ratio  
(CTR : MIN. 50% at  $I_F=5mA$ ,  $V_{CE}=5V$ ).
- High isolation voltage between input and output.  
( $V_{ISO}=5,000Vrms$ )

#### APPLICATIONS

- Feedback circuit in power supply.
- Switching Mode Power Supply.
- System appliances, Measuring instruments.
- Registers, Copiers, Automatic vending machines.
- Electric home appliances such as fan heaters, etc.

#### BLOCK DIAGRAM AND PIN CONFIGURATIONS (TOP VIEW)

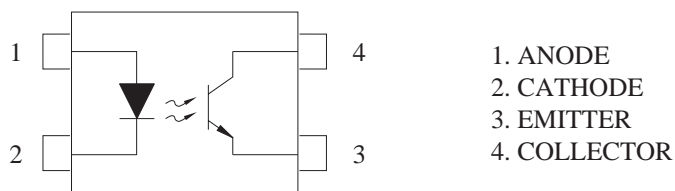

#### RANK TABLE OF CURRENT TRANSFER RATIO(CTR)

RANK MARK	CTR (%)	TEST CONDITION
(None)	50~600	$I_F=5mA$ , $V_{CE}=5V$ , $T_a=25^\circ C$
A	80~160	
B	130~260	
C	200~400	
D	300~600	
L	50~100	

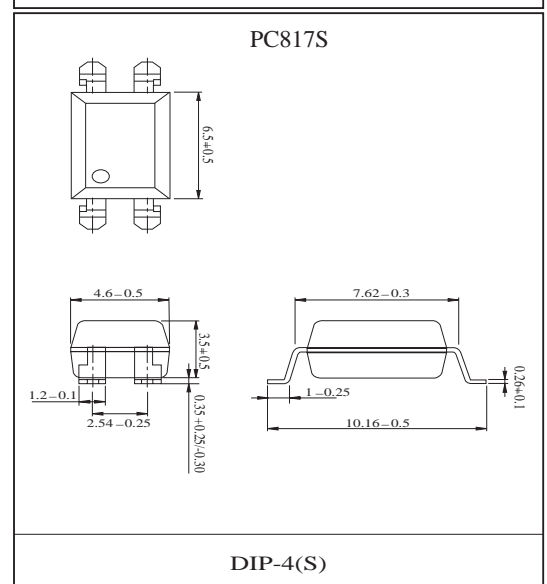
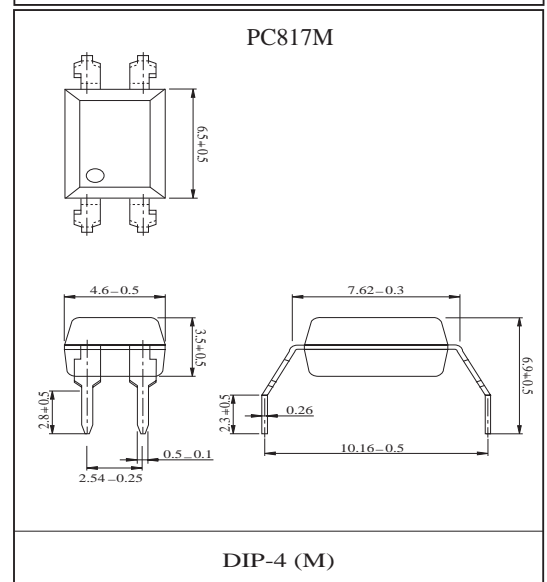
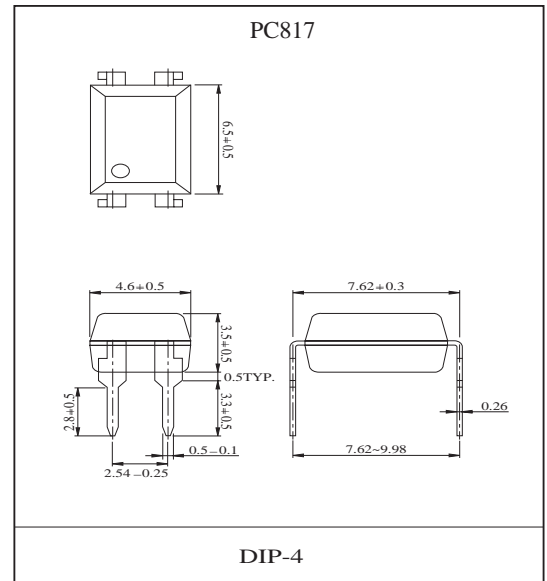



# PC817

## MAXIMUM RATING (Ta=25°C)

CHARACTERISTIC		SYMBOL	RATING	UNIT
Input	Forward Current	I <sub>F</sub>	50	mA
	Reverse Voltage	V <sub>R</sub>	6	V
	Power Dissipation	P <sub>D</sub>	70	mW
Output	Collector Power Dissipation	P <sub>C</sub>	150	mW
	Collector Current	I <sub>C</sub>	50	mA
	Collector-Emitter Voltage	V <sub>CEO</sub>	80	V
	Emitter-Collector Voltage	V <sub>ECO</sub>	6	V
Total Power Dissipation		P <sub>tot</sub>	200	mW
Isolation Voltage		V <sub>ISO</sub>	5000	V <sub>rms</sub>
Operating Temperature		T <sub>opr</sub>	-50 ~ 110	°C
Storage Temperature		T <sub>stg</sub>	-55 ~ 125	°C
Soldering Temperature		T <sub>sol</sub>	260	°C

## ELECTRO-OPTICAL CHARACTERISTICS (Ta=25°C unless otherwise noted)

CHARACTERISTIC		SYMBOL	TEST CONDITION	MIN.	TYP.	MAX.	UNIT
Input	Forward	V <sub>F</sub>	I <sub>F</sub> =20mA	-	1.2	1.4	V
	Reverse Current	I <sub>R</sub>	V <sub>R</sub> =4V	-	-	10	uA
	Terminal Capacitance	C <sub>t</sub>	V=0, f=1kHz	-	30	250	pF
Output	Collector Dark Current	I <sub>CEO</sub>	V <sub>CE</sub> =20V, I <sub>F</sub> =0	-	-	100	nA
	Collector-Emitter Breakdown Voltage	BV <sub>CEO</sub>	I <sub>C</sub> =0.1mA, I <sub>F</sub> =0	80	-	-	V
	Emitter-Collector Breakdown Voltage	BV <sub>ECO</sub>	10uA, I <sub>F</sub> =0	6	-	-	V
Transfer Characteristics	*Current Transfer Ratio	CTR	I <sub>F</sub> =5mA, V <sub>CE</sub> =5V	50	-	600	%
	Collector-Emitter Saturation Voltage	V <sub>CE(sat)</sub>	I <sub>F</sub> =20mA, I <sub>C</sub> =1mA	-	0.1	0.2	V
	Isolation Resistance	R <sub>ISO</sub>	DC500V, 40~60% R.H.	5 × 10 <sup>10</sup>	1 × 10 <sup>11</sup>	-	Ω
	Floating Capacitance	C <sub>f</sub>	V=0, f=1MHz	-	0.6	1.0	pF
	Cut-off Frequency	F <sub>C</sub>	V <sub>CE</sub> =5V, I <sub>C</sub> =2mA, R <sub>L</sub> =100Ω, -3dB	-	80	-	kHz
	Rise Time	T <sub>r</sub>	V <sub>CE</sub> =2V, I <sub>C</sub> =2mA, R <sub>L</sub> =100Ω	-	4	18	us
	Fall Time	T <sub>f</sub>	V <sub>CE</sub> =2V, I <sub>C</sub> =2mA, R <sub>L</sub> =100Ω	-	3	18	us

$$* CTR = \frac{I_C}{I_F} \times 100\%$$

Forward Current vs. Ambient Temperature

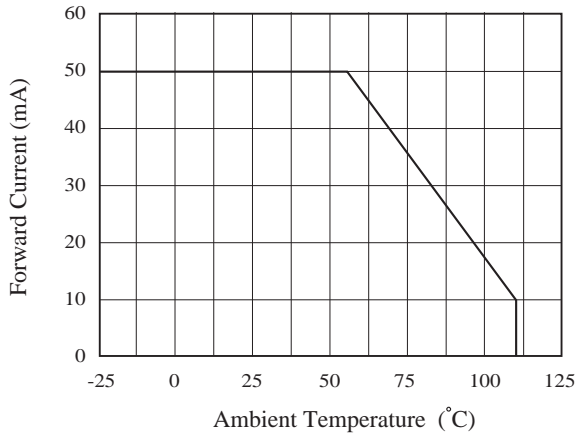

Collector Power Dissipation vs. Ambient Temperature

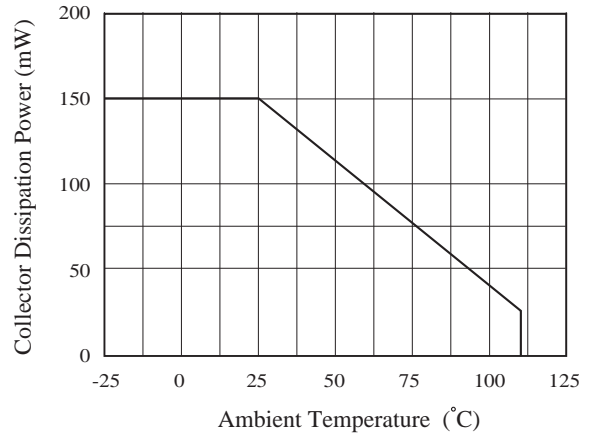

Current Transfer Ratio vs. Forward Current

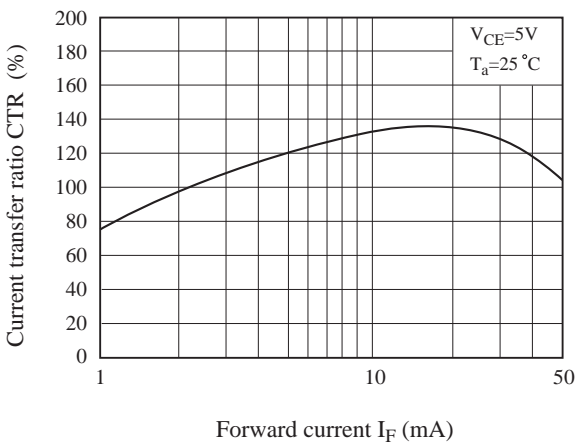

Forward Current vs. Forward Voltage

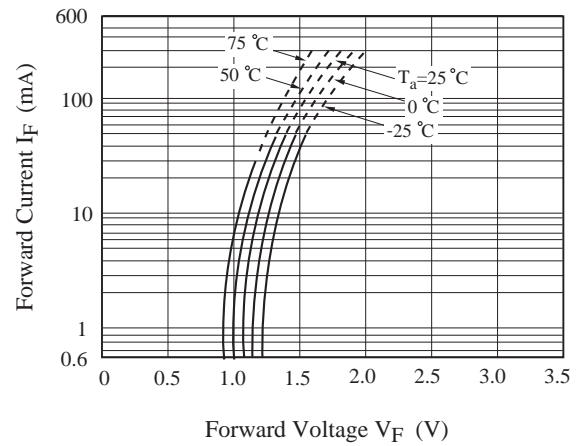

Collector Current vs. Collector-Emitter Voltage

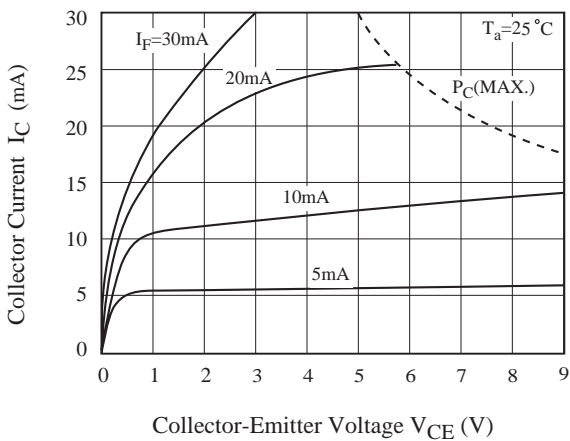

Relative Current Transfer Ratio vs. Ambient Temperature

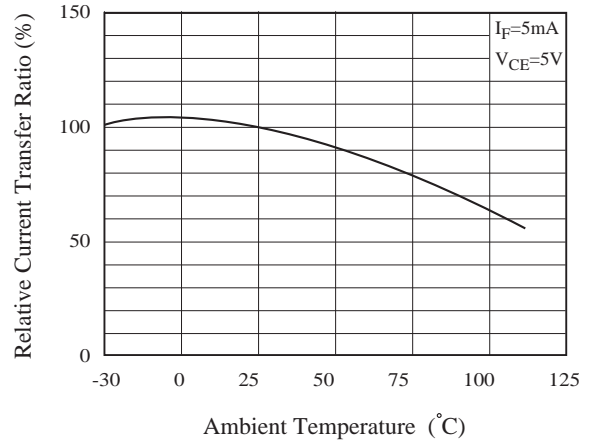

Collector-Emitter Saturation Voltage vs. Ambient Temperature

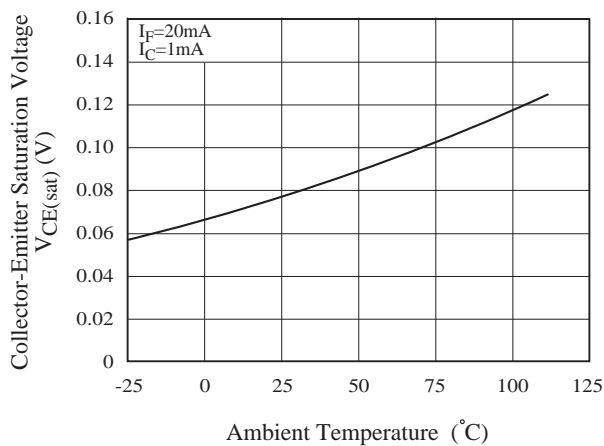

Collector Dark Current vs. Ambient Temperature

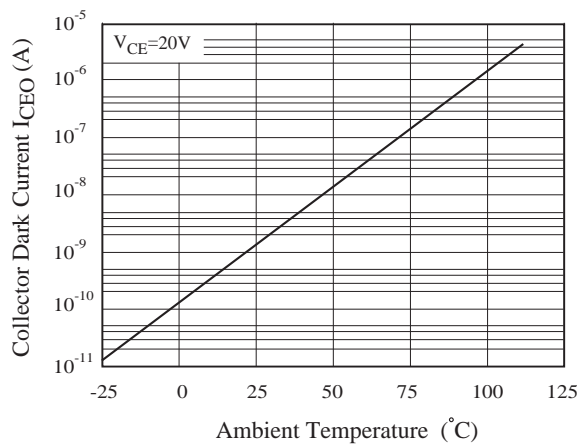

Response Time vs. Load Resistance

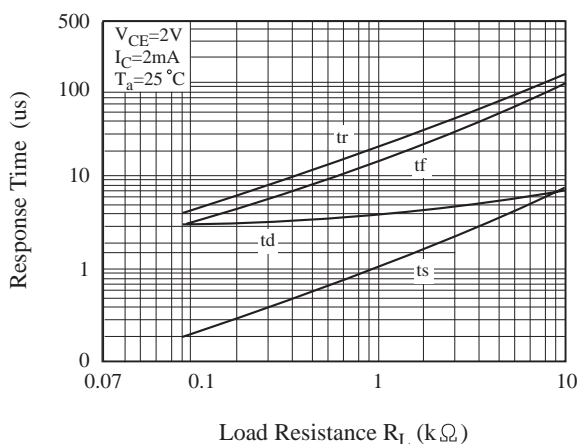

Frequency Response

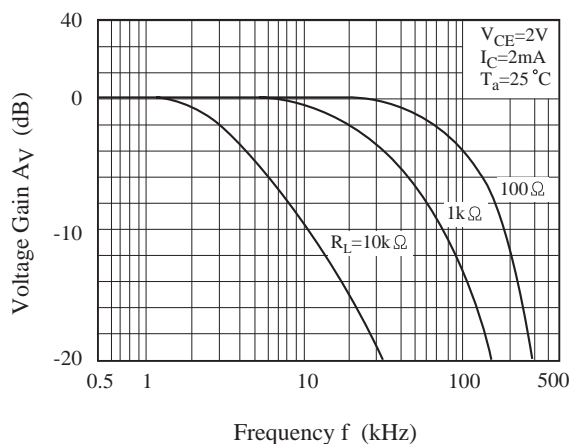

Collector-Emitter Saturation Voltage vs. Forward Current

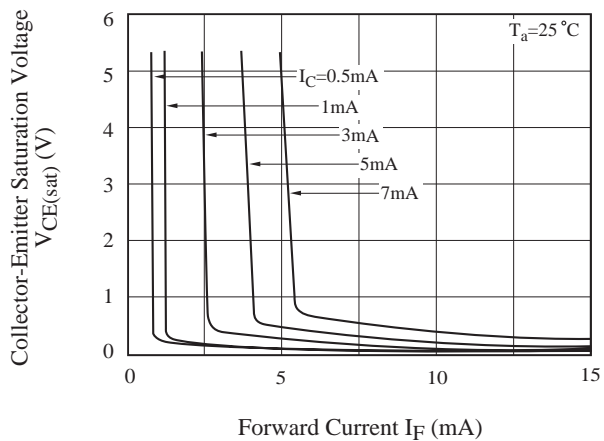

TEST Circuit for Response Time

