

FM1A025120K

N-Channel SiC Power MOSFET

V_{DS}	=	1200	V
$R_{DS(on)}$	=	25	mΩ
$I_D@25^{\circ}C$	=	65	A

Features

- High Blocking Voltage with Low On-Resistance
- High Speed Switching with Low Capacitance
- Easy to Parallel and Simple to Drive

Benefits

- Higher System Efficiency
- Reduced Cooling Requirements
- Increased Power Density
- Increased System Switching Frequency

Applications

- Power Supplies
- High Voltage DC/DC Converters
- Motor Drives
- Switch Mode Power Supplies
- Pulsed Power applications

Package

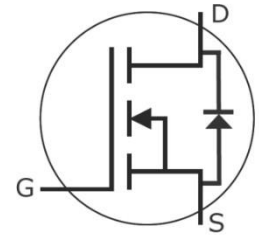
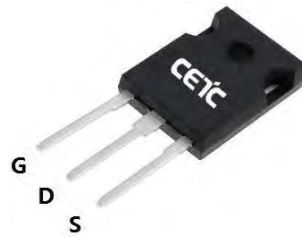

Part Number	Package
FM1A025120K	TO-247-3

Maximum Ratings ($T_c=25^{\circ}C$ unless otherwise specified)

Symbol	Parameter	Value	Unit	Test Conditions	Note
V_{DSmax}	Drain-Source Voltage	1200	V	$V_{GS}=0V, I_D=100\mu A$	
V_{GSmax}	Gate-Source Voltage	-10/+25	V	Absolute maximum values	
V_{GSop}	Gate-Source Voltage	-5/+20	V	Recommended operational values	
I_D	Continuous Drain Current	65	A	$V_{GS}=20V, T_c=25^{\circ}C$	
		43		$V_{GS}=20V, T_c=100^{\circ}C$	
$I_{D(pulse)}$	Pulsed Drain Current	200	A	Pulse width t_p limited by T_{Jmax}	
P_D	Power Dissipation	370	W	$T_c=25^{\circ}C, T_J=150^{\circ}C$	
T_J, T_{STG}	Operating Junction and Storage Temperature	-55 to +150	$^{\circ}C$		



FM1A025120K

Electrical Characteristics ($T_C=25^\circ\text{C}$ unless otherwise specified)

Symbol	Parameter	Min.	Typ.	Max.	Unit	Test Conditions	Note
$V_{(BR)DSS}$	Drain-Source Breakdown Voltage	1200	/	/	V	$V_{GS}=0V, I_D=100\mu A$	
$V_{GS(th)}$	Gate Threshold Voltage	1.9	2.4	4.0	V	$V_{DS}=V_{GS}, I_D=15mA$	Fig. 11
		/	1.7	/		$V_{DS}=V_{GS}, I_D=15mA, T_J=150^\circ\text{C}$	
I_{DSS}	Zero Gate Voltage Drain Current	/	1	100	μA	$V_{DS}=1200V, V_{GS}=0V$	
I_{GSS+}	Gate-Source Leakage Current	/	10	250	nA	$V_{DS}=0V, V_{GS}=25V$	
I_{GSS-}	Gate-Source Leakage Current	/	10	250	nA	$V_{DS}=0V, V_{GS}=-10V$	
$R_{DS(on)}$	Drain-Source On-State Resistance	/	25	34	m Ω	$V_{GS}=20V, I_D=50A$	Fig. 4,5,6
		/	43	/		$V_{GS}=20V, I_D=50A, T_J=150^\circ\text{C}$	
C_{iss}	Input Capacitance	/	4200	/	pF	$V_{GS}=0V$	Fig. 15,16
C_{oss}	Output Capacitance	/	250	/		$V_{DS}=1000V$	
C_{rss}	Reverse Transfer Capacitance	/	16	/		$f=1MHz$	
E_{oss}	C_{oss} Stored Energy	/	126	/		$V_{AC}=25mV$	
E_{ON}	Turn-On Switching Energy	/	1.8	/	mJ	$V_{DS}=800V, V_{GS}=-5V/20V$	
E_{OFF}	Turn-Off Switching Energy	/	0.6	/		$I_D=50A, R_{G(ext)}=2.5\Omega, L=412\mu H$	
$t_{d(on)}$	Turn-On Delay Time	/	15	/	ns	$V_{DS}=800V, V_{GS}=-5V/20V, I_D=50A$ $R_{G(ext)}=2.5\Omega, R_L=16\Omega$	
t_r	Rise Time	/	12	/			
$t_{d(off)}$	Turn-Off Delay Time	/	34	/			
t_f	Fall Time	/	7	/			
$R_{G(int)}$	Internal Gate Resistance	/	2.1	/	Ω	$f=1MHz, V_{AC}=25mV$	
Q_{GS}	Gate to Source Charge	/	54	/	nC	$V_{DS}=800V$	
Q_{GD}	Gate to Drain Charge	/	29	/		$V_{GS}=-5V/20V$	
Q_G	Total Gate Charge	/	195	/		$I_D=50A$	

Reverse Diode Characteristics

Symbol	Parameter	Typ.	Max.	Unit	Test Conditions	Note
V_{SD}	Diode Forward Voltage	3.5	/	V	$V_{GS}=-5V, I_{SD}=25A$	Fig. 8,9,10
		3.3	/		$V_{GS}=-5V, I_{SD}=25A, T_J=150^\circ\text{C}$	
I_S	Continuous Diode Forward Current	/	98	A	$T_C=25^\circ\text{C}$	
t_{rr}	Reverse Recover Time	50	/	ns	$V_R=800V, I_{SD}=50A$	
Q_{rr}	Reverse Recovery Charge	216	/	nC		
I_{rrm}	Peak Reverse Recovery Current	7.2	/	A		

Thermal Characteristics

Symbol	Parameter	Typ.	Max.	Unit	Test Conditions	Note
$R_{\theta JC}$	Thermal Resistance from Junction to Case	0.25	/	$^\circ\text{C}/W$		
$R_{\theta JA}$	Thermal Resistance from Junction to Ambient	/	40			

Typical Performance

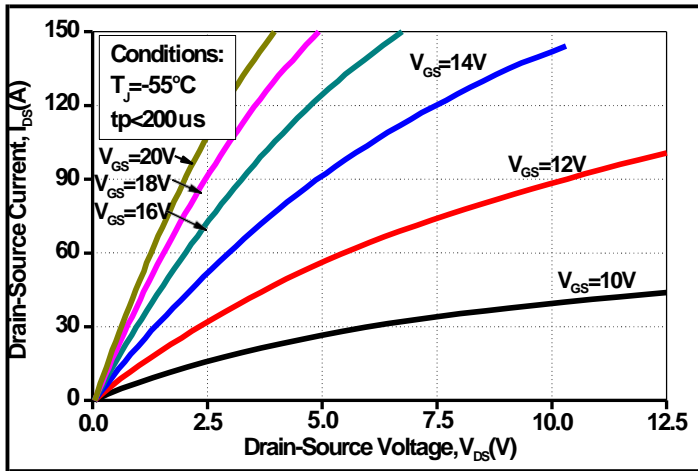

Figure 1. Output Characteristics $T_j = -55^\circ\text{C}$

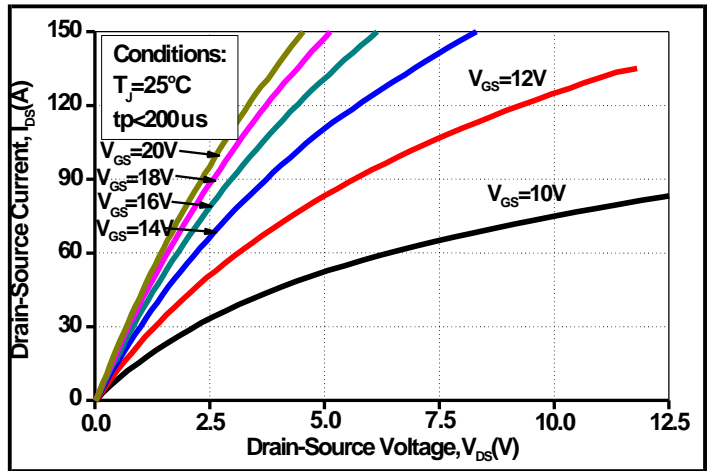

Figure 2. Output Characteristics $T_j = 25^\circ\text{C}$

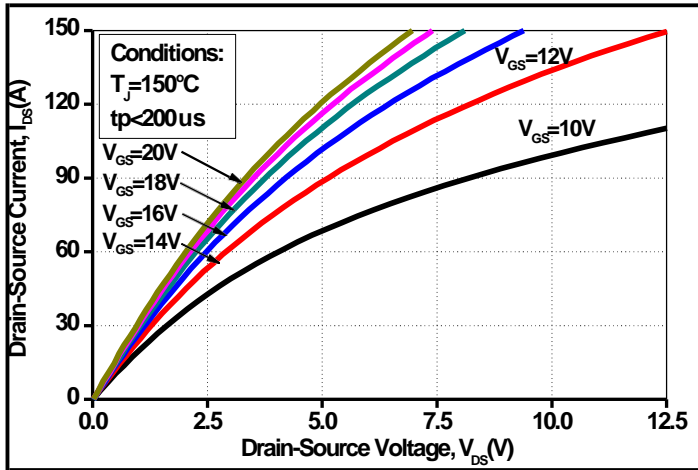

Figure 3. Output Characteristics $T_j = 150^\circ\text{C}$

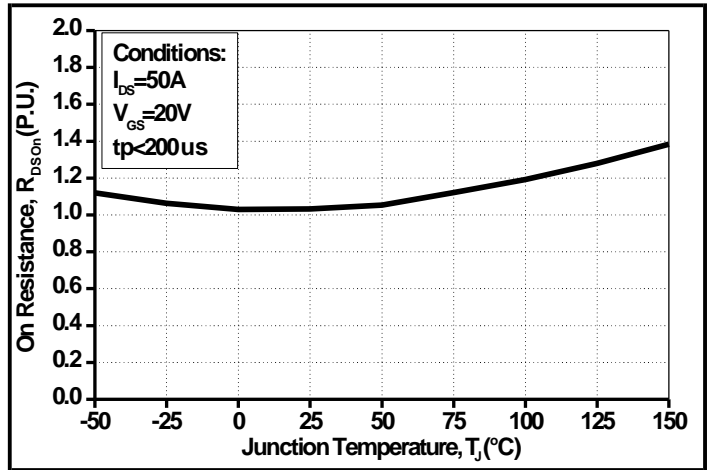

Figure 4. Normalized On-Resistance vs. Temperature

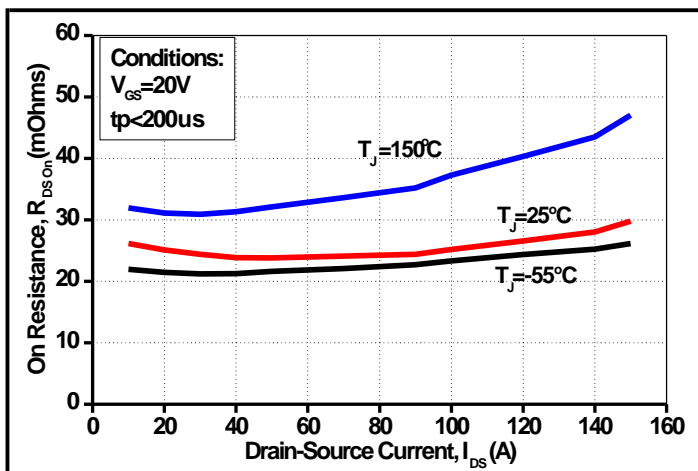

Figure 5. On-Resistance vs. Drain Current
For Various Temperatures

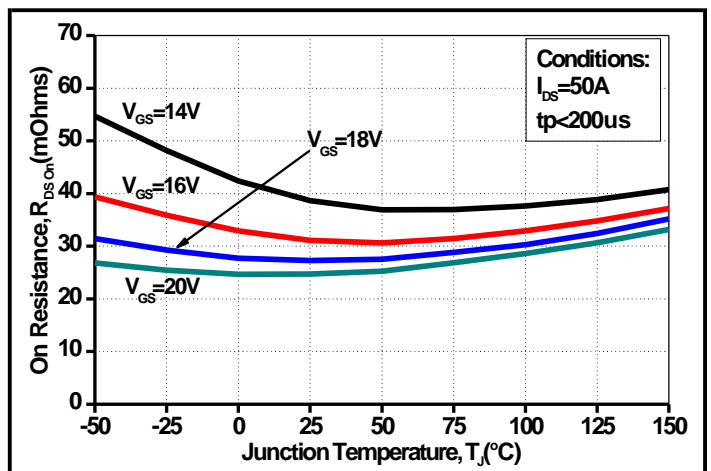

Figure 6. On-Resistance vs. Temperature
For Various Gate Voltage

Typical Performance

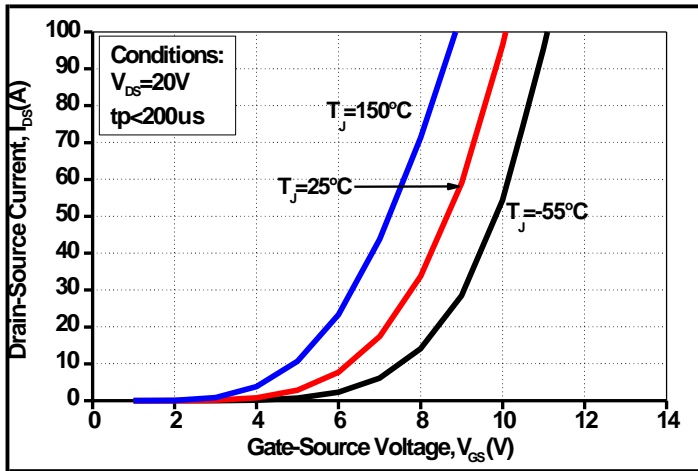

Figure 7. Transfer Characteristic for Various Junction Temperatures

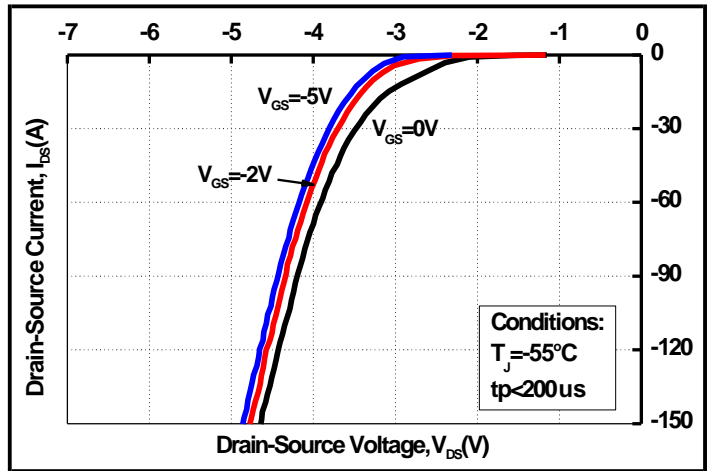

Figure 8. Body Diode Characteristic at -55°C

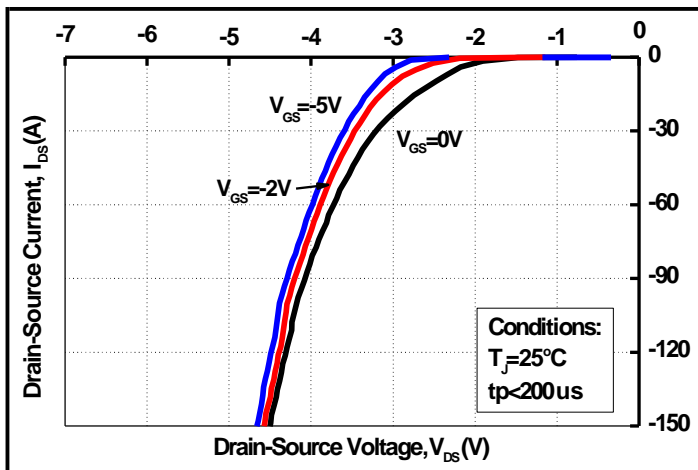

Figure 9. Body Diode Characteristic at 25°C

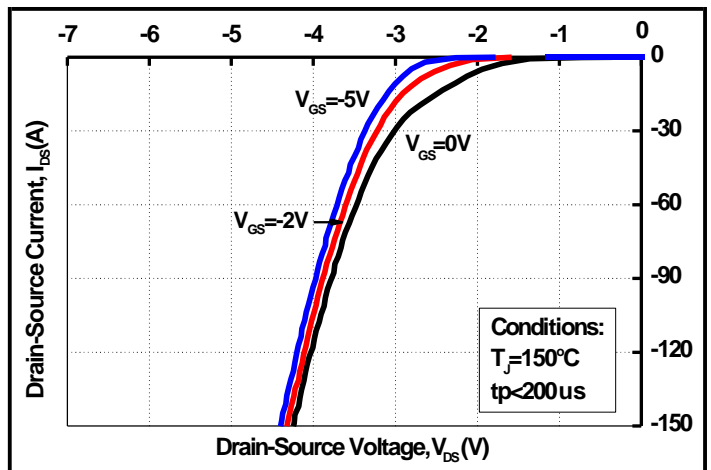

Figure 10. Body Diode Characteristic at 150°C

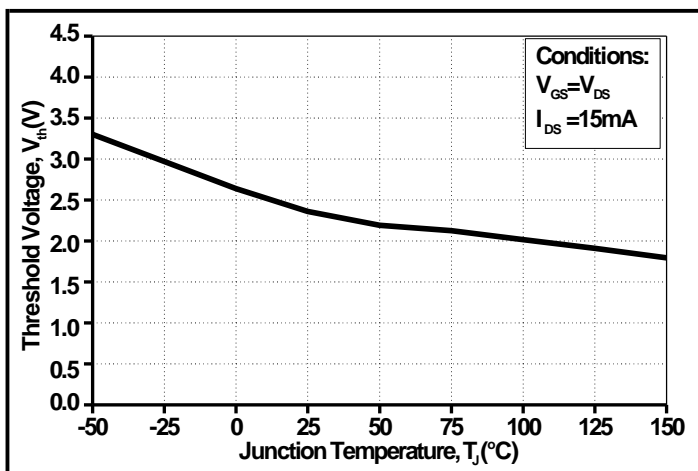

Figure 11. Threshold Voltage vs. Temperature

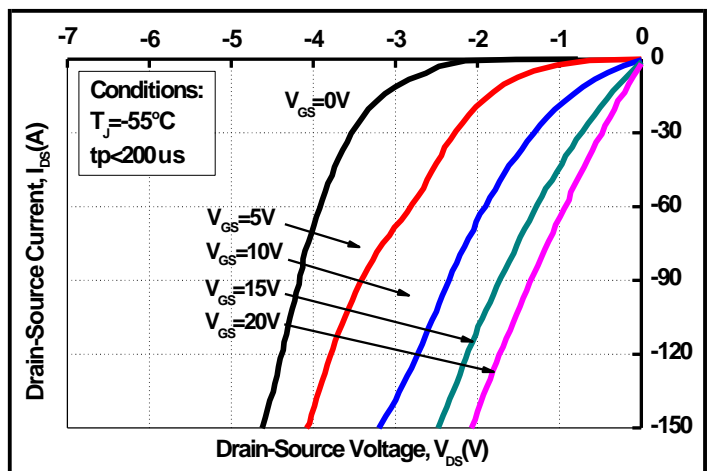

Figure 12. 3rd Quadrant Characteristic at -55°C

Typical Performance

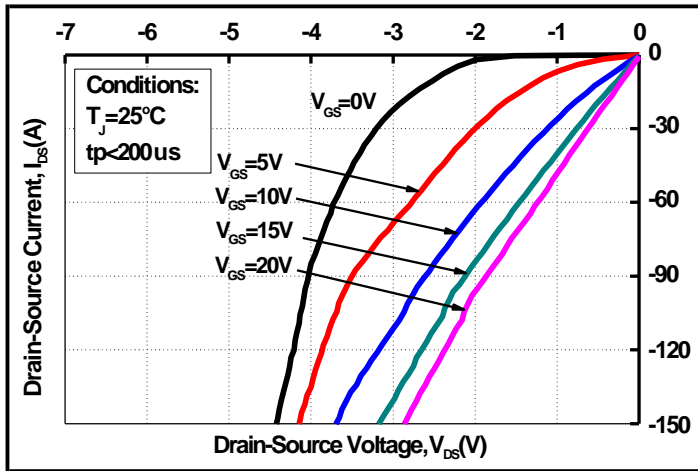

Figure 13. 3rd Quadrant Characteristic at 25°C

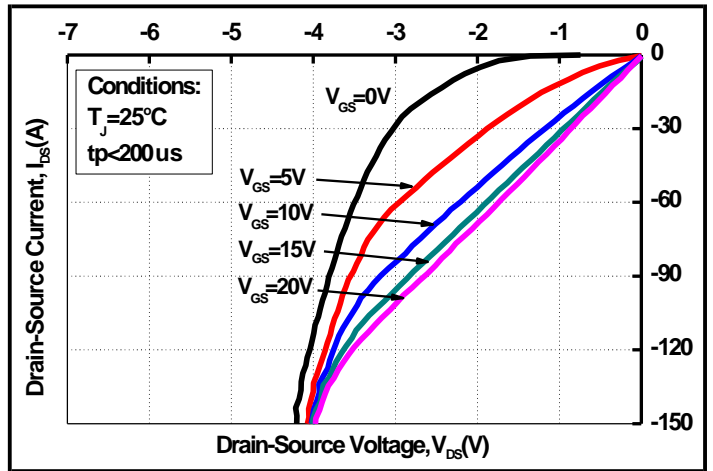

Figure 14. 3rd Quadrant Characteristic at 150°C

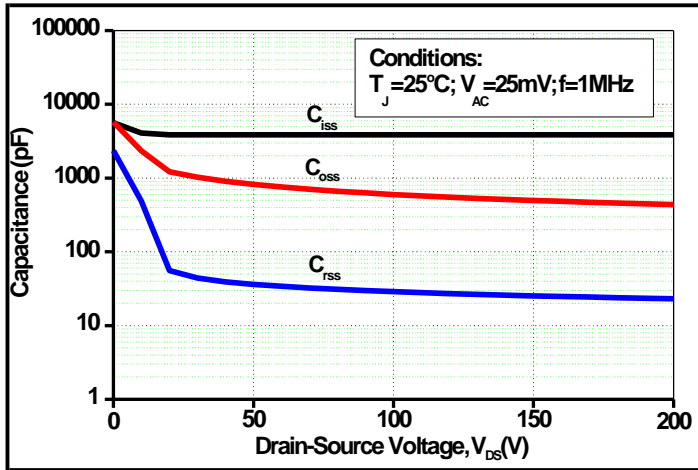

Figure 15. Capacitances vs. Drain-Source Voltage (0 - 200V)

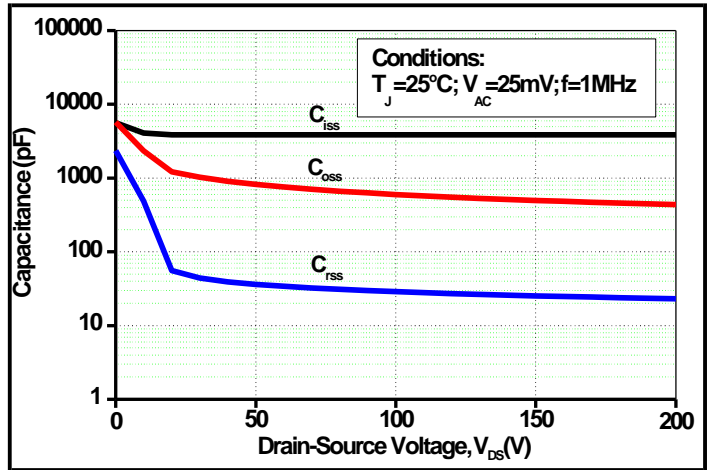
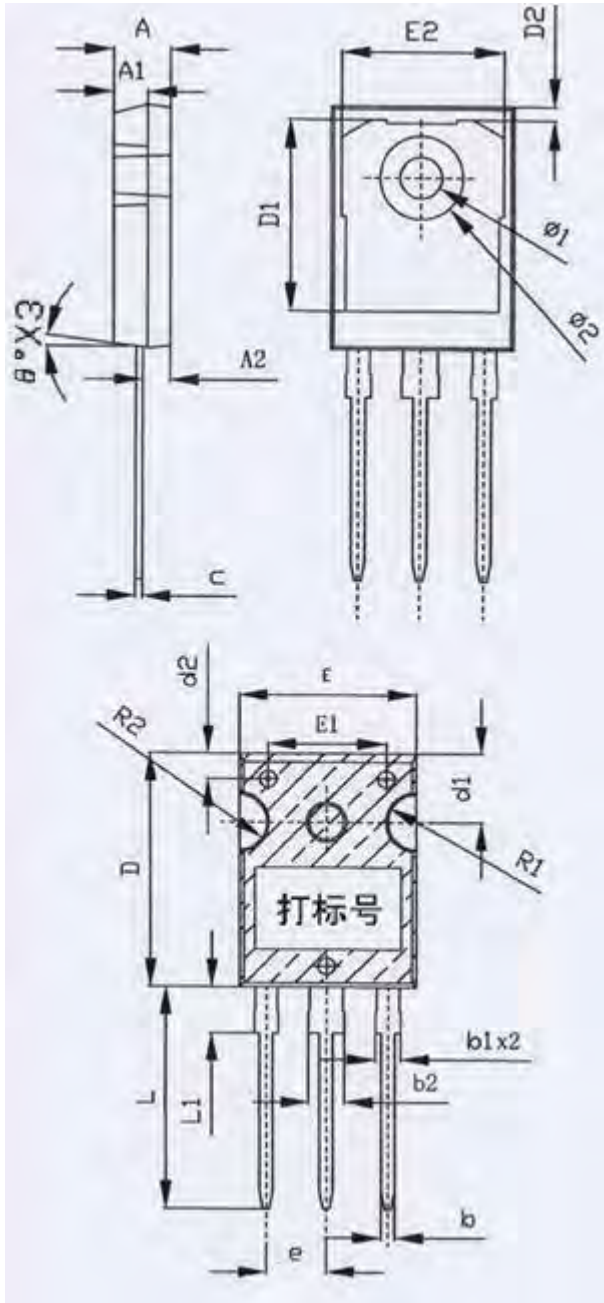

Figure 16. Capacitances vs. Drain-Source Voltage (0 - 1000V)

Package Dimensions

Package TO-247-3



SYMBOLS	DIMENSIONS IN MILLIMETERS		
	MIN	NOM	MAX
A	4.9	5	5.1
A1	2.9	3	3.1
A2	2.31	2.36	2.41
b	1.16	1.2	1.26
b1	2.05	-	2.2
b2	3.05	-	3.2
c	0.58	0.6	0.66
D	20.9	21	21.1
D1	16.46	16.56	16.76
D2		1.17	
d1	6.05	6.15	6.25
d2	2.2	2.3	2.4
E	15.7	15.8	15.9
E1		10.5	
E2		14.02	
e	-	1.27 _{bc}	-
L	19.82	19.92	20.02
L1	1.88	1.98	2.08
θ	0°	7°	8°
R1	-	2.7	-
R2	-	2.5	-
$\Phi 1$		3.6	
$\Phi 2$	-	7.19	-