

Features

- Built-in bias resistors enable the configuration of an inverter circuit without connecting external input resistors(see equivalent circuit)
- The bias resistors consist of thin-film resistors with complete isolation to allow negative biasing of the input.They also have the advantage of almost completely eliminating parasitic effects
- Only the on/off conditions need to be set for operation, making device design easy

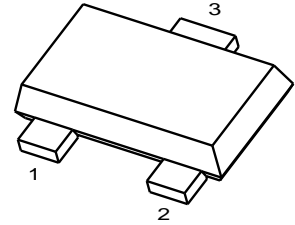

SOT-723

INFORMATION

Part Number	MARKING	Package
DTC705EM	E42	SOT- 723

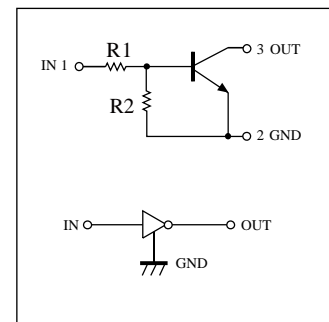



DTC705EM

MAXIMUM RATINGS(Ta=25°C unless otherwise noted)

Symbol	Parameter	Limits	Unit
V _{CC}	Supply Voltage	50	V
V _{IN}	Input Voltage	-5~+12	V
I _O	Output Current	100	mA
P _D	Power Dissipation	100	mW
T _J	Junction Temperature	150	°C
T _{stg}	Storage Temperature	-55~+150	°C

ELECTRICAL CHARACTERISTICS (Ta=25°C unless otherwise specified)

Parameter	Symbol	Conditions	Min	Typ	Max	Unit
Input voltage	V _{I(off)}	V _{CC} =5V, I _O =100μA	0.5			V
	V _{I(on)}	V _O =0.3V, I _O =5mA			1.1	V
Output voltage	V _{O(on)}	I _O /I _I =5mA/0.25mA		0.1	0.3	V
Input current	I _I	V _I =5V			3.6	mA
Output current	I _{O(off)}	V _{CC} =50V, V _I =0			0.5	μA
DC current gain	G _I	V _O =5V, I _O =10mA	80			
Input resistance	R ₁		1.54	2.2	2.86	kΩ
Resistance ratio	R ₂ /R ₁		17	21	26	
Transition frequency	f _T	V _O =10V, I _O =5mA, f=100MHz		250		MHz



DTC705EM

Typical Performance Characteristics

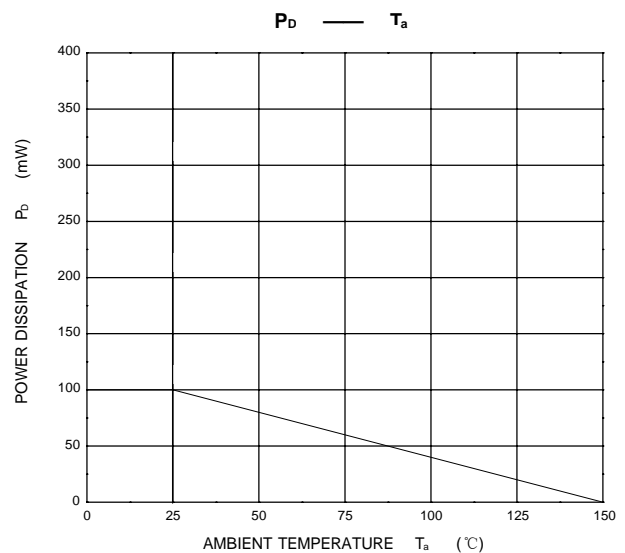
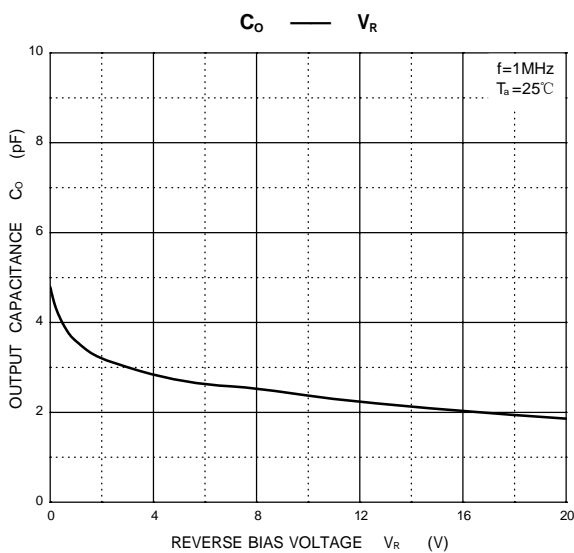
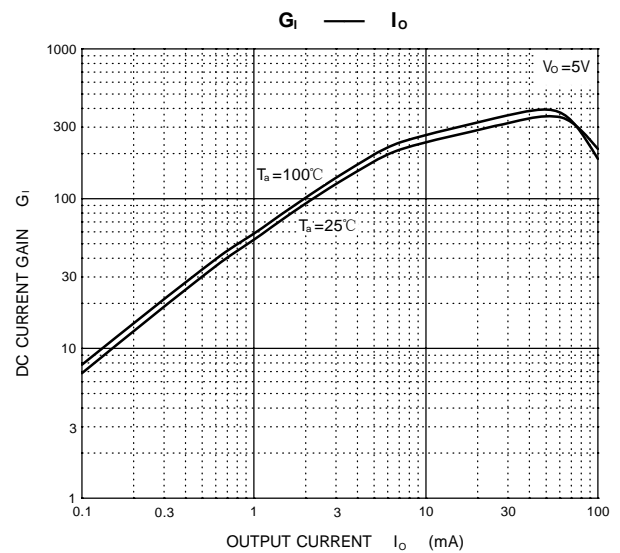
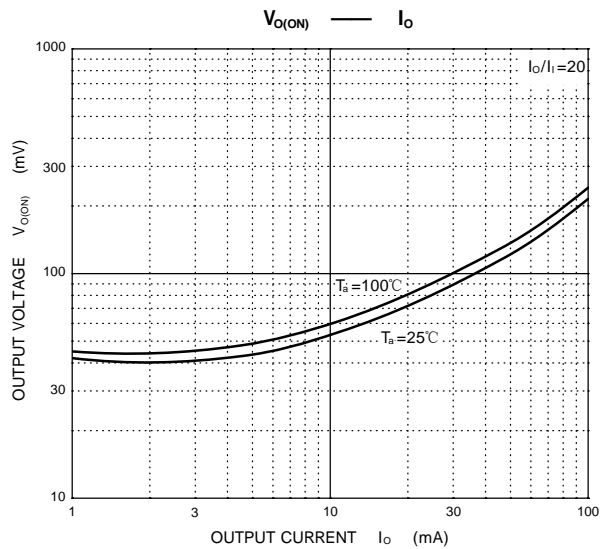
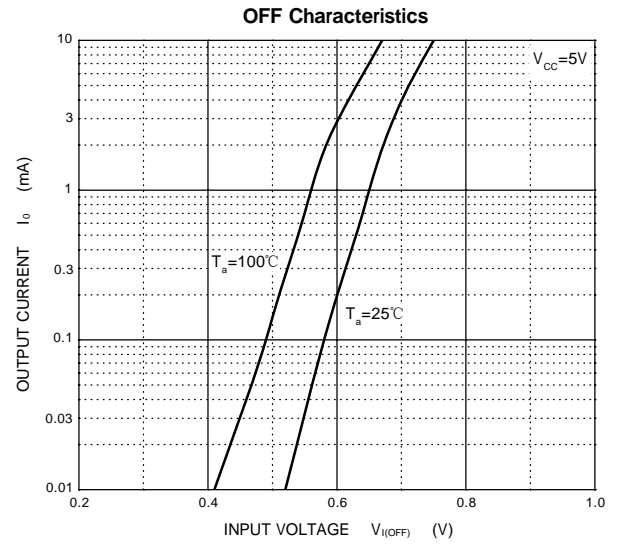
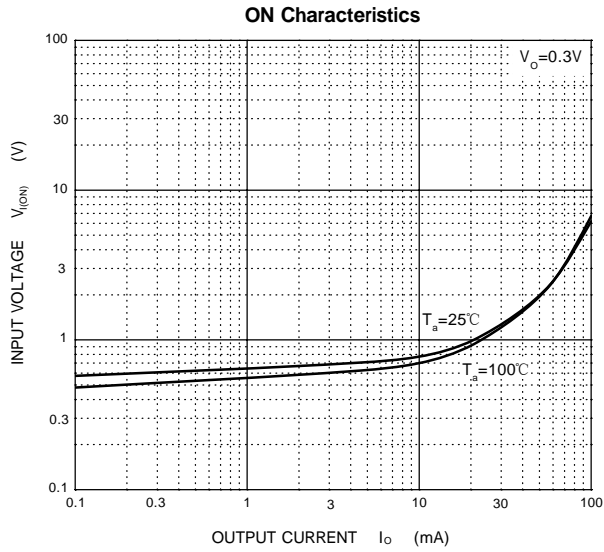

■ SOT-723

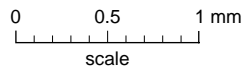
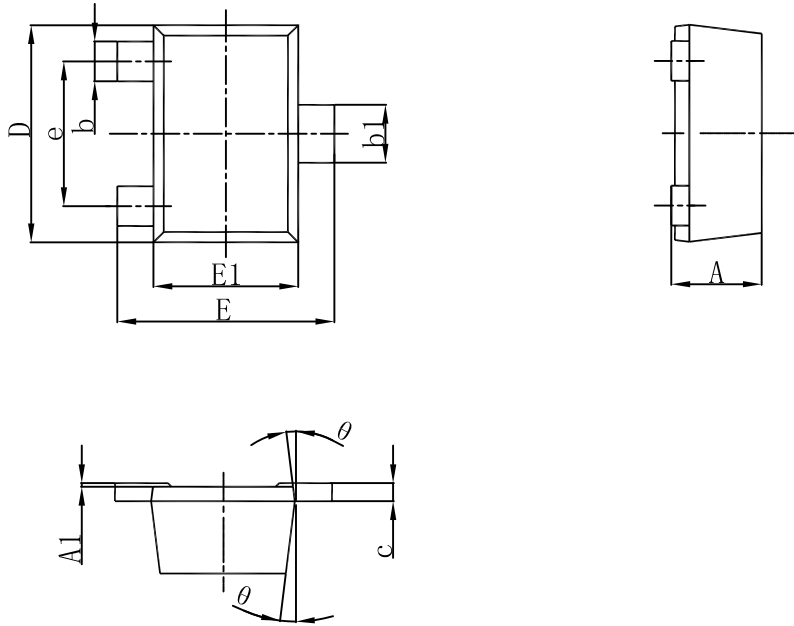

DIMENSIONS (mm are the original dimensions)

UNIT	A	A ₁ max	b	b ₁	c	D	E	E ₁
mm	0.43 0.50	0.05	0.17 0.27	0.27 0.37	0.08 0.15	1.15 1.25	0.15 0.25	0.75 0.85