

P- Channel MOSFET

$V_{(BR)DSS}$	$R_{DS(on) MAX}$	I_D
- 12V	21mΩ@- 4.5V	- 16A
	27mΩ@- 2.5V	

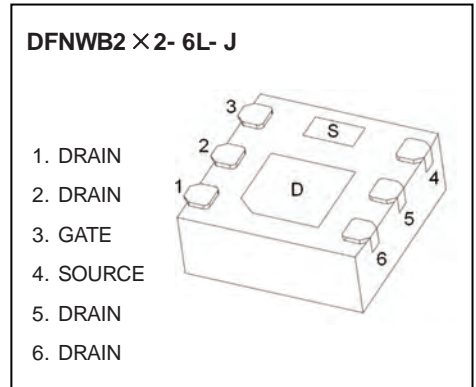

DESCRIPTION

The FTK1216 uses advanced trench technology to provide excellent $R_{DS(on)}$, low gate charge and operation with low gate voltage. This device is suitable for use as a load switching application and a wide variety of other applications.

FEATURES

- Advanced trench MOSFET process technology
- Ultra low on-resistance with low gate charge

APPLICATIONS

- PWM application
- Load switch
- Battery charge in cellular handset

MARKING

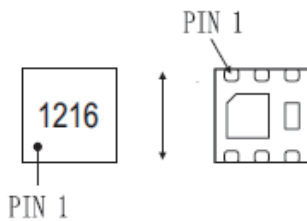

Equivalent Circuit

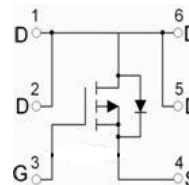

Maximum ratings ($T_a=25^{\circ}C$ unless otherwise noted)

Parameter	Symbol	Value	Unit
Drain-Source Voltage	V_{DSS}	-12	V
Gate-Source Voltage	V_{GS}	±8	
Drain Current-Continuous	I_D	-16	A
Drain Current-Pulsed (note 1)	I_{DM}	-65	
Power Dissipation (note 2 , $T_a=25^{\circ}C$)	P_D	2.5	W
Maximum Power Dissipation (note 3 , $T_c=25^{\circ}C$)		18	
Thermal Resistance from Junction to Ambient (note 4)	$R_{\theta JA}$	50	$^{\circ}C/W$
Thermal Resistance from Junction to Case (note 4)	$R_{\theta JC}$	6.9	
Junction Temperature	T_j	150	$^{\circ}C$
Storage Temperature	T_{STG}	-55 ~+150	



Electrical characteristics (T_a=25°C unless otherwise noted)

Parameter	Symbol	Test Condition	Min	Typ	Max	Unit
Off Characteristics						
Drain-Source Breakdown Voltage	V _{(BR)DSS}	V _{GS} = 0V, I _D = -250μA	-12			V
Gate-Body Leakage Current	I _{GSS}	V _{DS} = 0V, V _{GS} = ±8V			±100	nA
Zero Gate Voltage Drain Current	I _{DSS}	V _{DS} = -12V, V _{GS} = 0V			-1	μA
On Characteristics (note 5)						
Gate-Threshold Voltage	V _{GS(th)}	V _{DS} = V _{GS} , I _D = -250μA	-0.4	-0.7	-1	V
Drain-Source On-State Resistance	R _{DS(on)}	V _{GS} = -4.5V, I _D = -6.7A			21	mΩ
		V _{GS} = -2.5V, I _D = -6.2A			27	
Forward Transconductance	g _{FS}	V _{DS} = -10V, I _D = -6.7A		40		S
Dynamic Characteristics (note 6)						
Input Capacitance	C _{iSS}	V _{DS} = -10V, V _{GS} = 0V, f = 1MHz		2700		pF
Output Capacitance	C _{oSS}			680		
Reverse Transfer Capacitance	C _{rSS}			590		
Total Gate Charge	Q _g	V _{DS} = -6V, V _{GS} = -8V, I _D = -10A		60	100	nC
				35	48	
Gate-Source Charge	Q _{gs}	V _{DS} = -6V, V _{GS} = -4.5V, I _D = -10A		5		
Gate-Drain Charge	Q _{gd}			10		
Drain - Source Diode Characteristics						
Diode Forward Current (note 5)	I _S				-16	A
Diode Forward Voltage (note 4)	V _{SD}	V _{GS} = 0V, I _{SD} = -8A			-1.2	V

Notes:

1. Repetitive Rating: Pulse width limited by maximum junction temperature.
2. This test is performed with no heat sink at T_a=25°C.
3. This test is performed with infinite heat sink at T_c=25°C.
4. Surface mounted on FR4 board, t_≤10S.
5. Pulse Test: Pulse With ≤300μs, Duty Cycle ≤2%.
6. Guaranteed by design, not subject to production testing.



FTK1216

Typical Characteristics

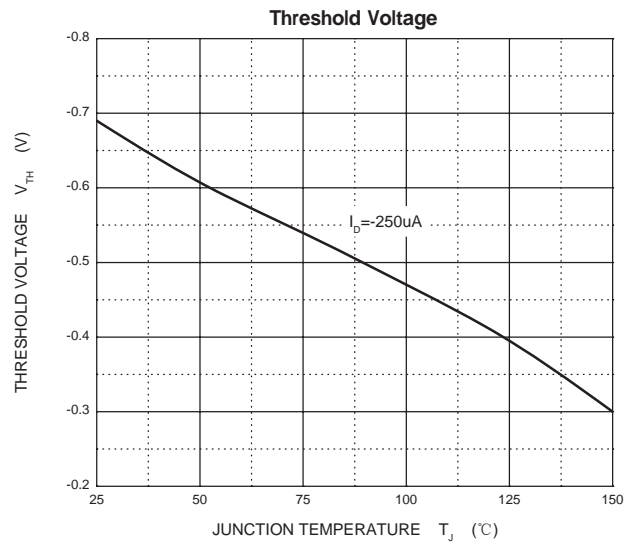
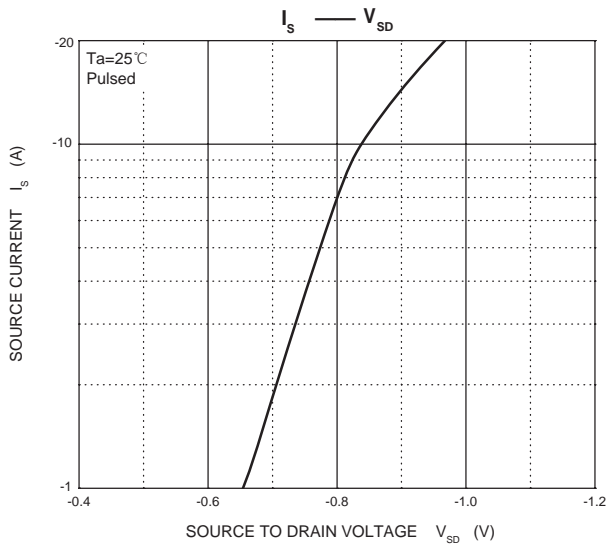
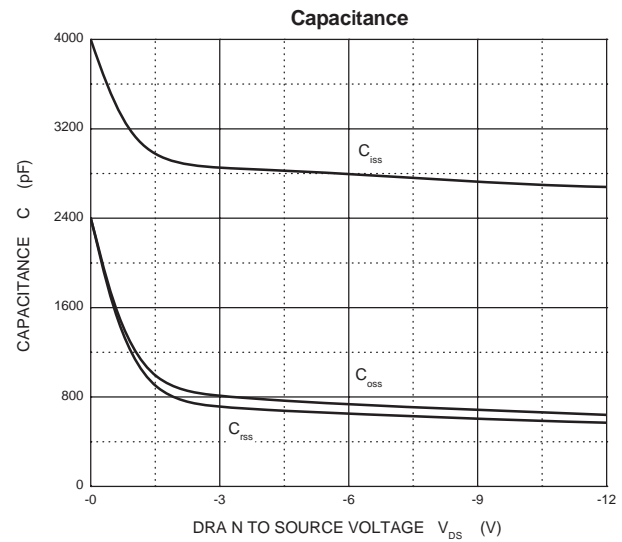
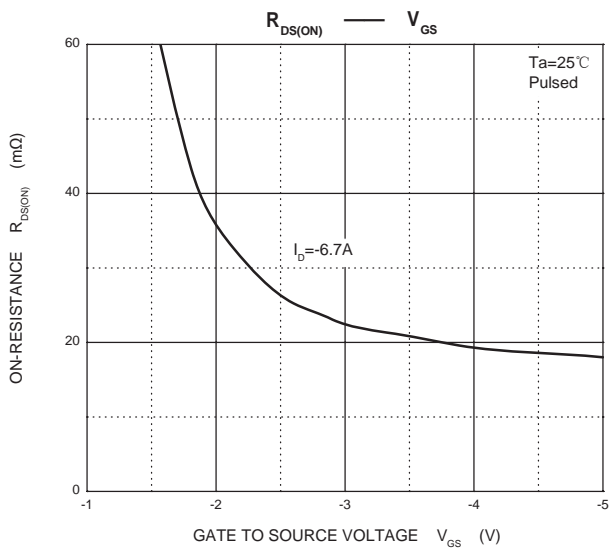
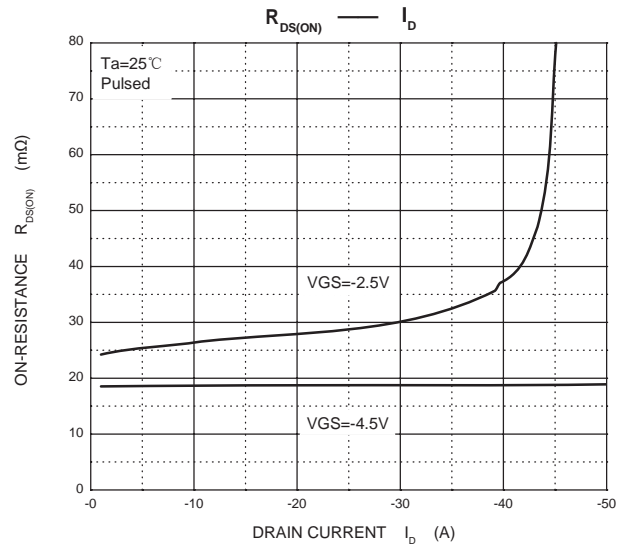
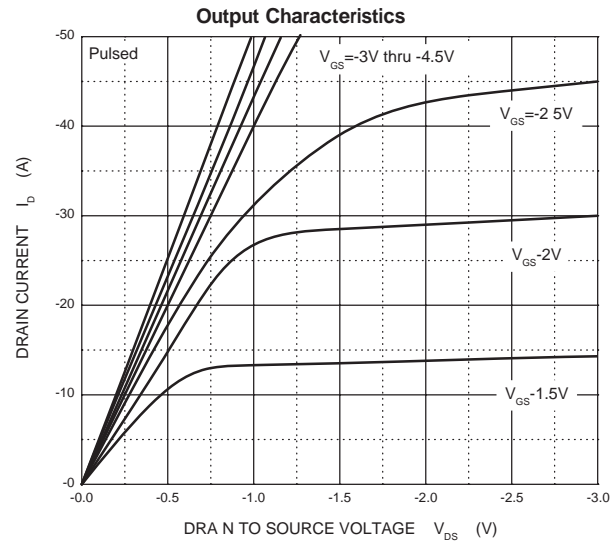

DFNWB2 × 2-6L-J Package Outline Dimensions (Unit:mm)

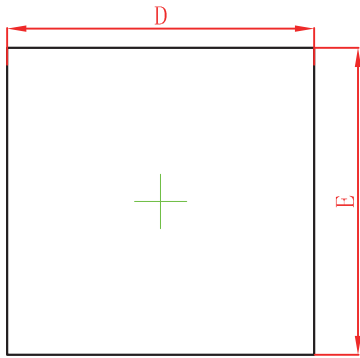

TOP VIEW

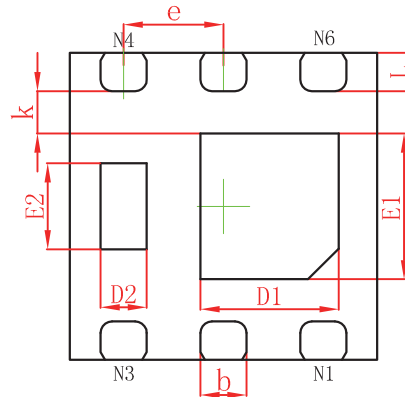

BOTTOM VIEW

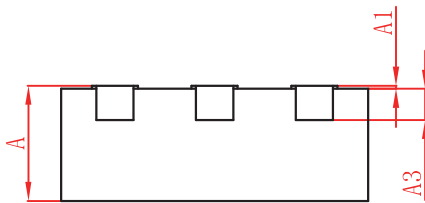

SIDE VIEW

Symbol	Dimensions In Millimeters		Dimensions In Inches	
	Min.	Max.	Min.	Max.
A	0.700/0.800	0.800/0.900	0.028/0.03	0.031/0.035
A1	0.000	0.050	0.000	0.002
A3	0.203REF.		0.008REF.	
D	1.924	2.076	0.076	0.082
E	1.924	2.076	0.076	0.082
D1	0.800	1.000	0.031	0.039
E1	0.850	1.050	0.033	0.041
D2	0.200	0.400	0.008	0.016
E2	0.460	0.660	0.018	0.026
k	0.200MIN.		0.008MIN.	
b	0.250	0.350	0.010	0.014
e	0.650TYP.		0.026TYP.	
L	0.174	0.326	0.007	0.013

DFNWB2 × 2-6L-J Suggested Pad Layout

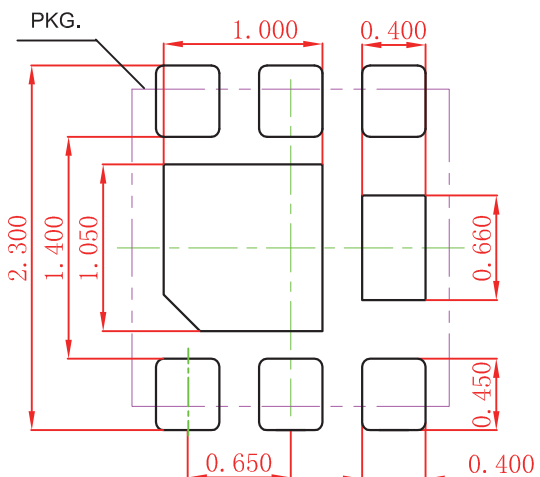

Note:
 1. Controlling dimension: in millimeters.
 2. General tolerance: ± 0.050mm.
 3. The pad layout is for reference purposes only.

DFNWB2X2-6L J Tape and Reel

DFNWB2×2-6L Embossed Carrier Tape

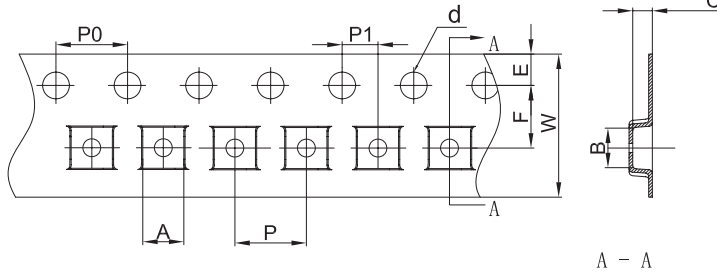

Packaging Description:

DFNWB2×2-6L parts are shipped in tape. The carrier tape is made from a dissipative (carbon filled) polycarbonate resin. The cover tape is a multilayer film (Heat Activated Adhesive in nature) primarily composed of polyester film, adhesive layer, sealant, and anti-static sprayed agent. These reeled parts in standard option are shipped with 3,000 units per 7" or 17.8cm diameter reel. The reels are clear in color and is made of polystyrene plastic (anti-static coated).

Dimensions are in millimeter										
Pkg type	A	B	C	d	E	F	P0	P	P1	W
DFNWB2×2-6L	2.30	2.30	1.10	Ø1.50	1.75	3.50	4.00	4.00	2.00	8.00
(Tolerance)	+/-0.05	+/-0.05	+/-0.05	+/-0.1	+/-0.1	+/-0.1	+/-0.1	+/-0.1	+/-0.1	+0.3/-0.1

DFNWB2×2-6L Tape Leader and Trailer

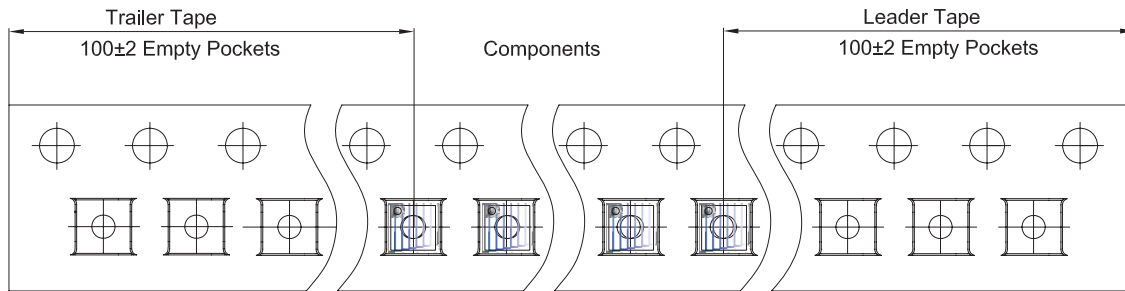

DFNWB2×2-6L Reel

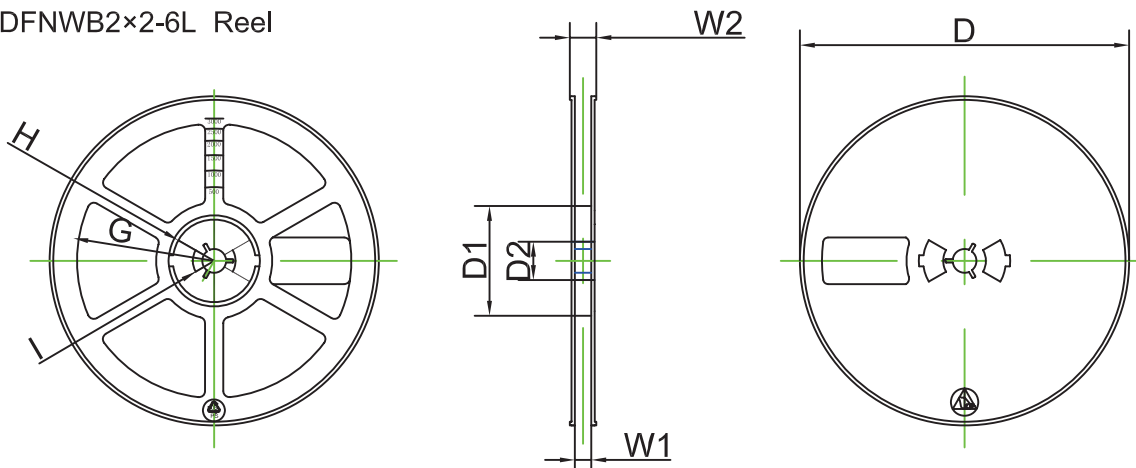

Dimensions are in millimeter								
Reel Option	D	D1	D2	G	H	I	W1	W2
7" Dia	Ø180.00	60.00	13.00	R78.00	R25.60	R11.50	9.50	13.10
Tolerance	+0/-3	+/-0.5	+/-0.2	+/-1	+/-1	+/-1	+/-1	+/-1.3

REEL	Reel Size	Box	Box Size(mm)	Carton	Carton Size(mm)	G.W.(kg)
3000 pcs	7 inch	30,000 pcs	203×203×195	120,000 pcs	438×438×220	