

DESCRIPTION

The FTK2312 uses advanced trench technology to provide excellent $R_{DS(ON)}$, low gate charge and operation with gate voltages as low as 2.5V. This device is suitable for use as a Battery protection or in other Switching application.

GENERAL FEATURES

- $V_{DS} = 20V, I_D = 4.5A$
 $R_{DS(ON)} < 40m\Omega @ V_{GS}=2.5V$
 $R_{DS(ON)} < 33m\Omega @ V_{GS}=4.5V$
- High Power and current handing capability
- Lead free product is acquired
- Surface Mount Package

APPLICATION

- Battery protection
- Load switch
- Power management

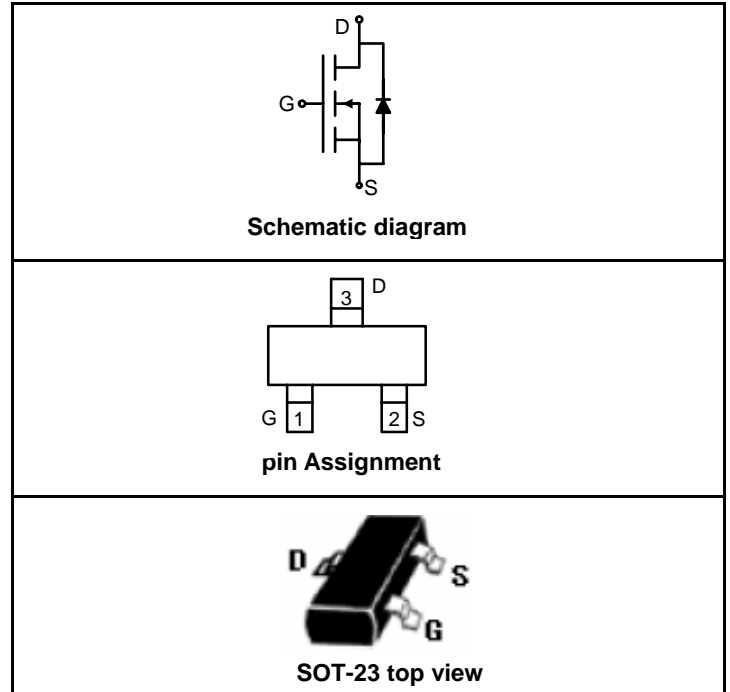

PACKAGE MARKING AND ORDERING INFORMATION

| Device Marking | Device | Device Package | Reel Size | Tape width | Quantity |
|----------------|---------|----------------|-----------|------------|------------|
| 2312 or N12 | FTK2312 | SOT-23 | Ø180mm | 8 mm | 3000 units |

ABSOLUTE MAXIMUM RATINGS (TA=25°C unless otherwise noted)

| Parameter | Symbol | Limit | Unit |
|---|----------------|------------|------|
| Drain-Source Voltage | V_{DS} | 20 | V |
| Gate-Source Voltage | V_{GS} | ±8 | V |
| Drain Current-Continuous@ Current-Pulsed (Note 1) | I_D | 4.5 | A |
| | I_{DM} | 13.5 | A |
| Maximum Power Dissipation | P_D | 1.25 | W |
| Operating Junction and Storage Temperature Range | T_J, T_{STG} | -55 To 150 | °C |

THERMAL CHARACTERISTICS

| | | | |
|--|-----------------|-----|------|
| Thermal Resistance, Junction-to-Ambient (Note 2) | $R_{\theta JA}$ | 100 | °C/W |
|--|-----------------|-----|------|

ELECTRICAL CHARACTERISTICS (TA=25°C unless otherwise noted)

| Parameter | Symbol | Condition | Min | Typ | Max | Unit |
|------------------------------------|--------------|-------------------------------|-----|------|------|------|
| OFF CHARACTERISTICS | | | | | | |
| Drain-Source Breakdown Voltage | BV_{DSS} | $V_{GS}=0V, I_D=250\mu A$ | 20 | | | V |
| Zero Gate Voltage Drain Current | I_{DSS} | $V_{DS}=20V, V_{GS}=0V$ | | | 1 | μA |
| Gate-Body Leakage Current | I_{GSS} | $V_{GS}=\pm 8V, V_{DS}=0V$ | | | ±100 | nA |
| ON CHARACTERISTICS (Note 3) | | | | | | |
| Gate Threshold Voltage | $V_{GS(th)}$ | $V_{DS}=V_{GS}, I_D=250\mu A$ | 0.5 | 0.65 | 1.2 | V |
| Drain-Source On-State Resistance | $R_{DS(ON)}$ | $V_{GS}=2.5V, I_D=4.5A$ | | 33 | 40 | mΩ |
| | | $V_{GS}=4.5V, I_D=5A$ | | 27 | 33 | mΩ |
| Forward Transconductance | g_{FS} | $V_{DS}=10V, I_D=5A$ | | 10 | | S |

Electrical characteristics ($T_a=25^{\circ}\text{C}$ unless otherwise noted)

| DYNAMIC CHARACTERISTICS (Note4) | | | | | | |
|------------------------------------|--------------|--|--|-----|-----|----|
| Input Capacitance | C_{iss} | $V_{DS}=8V, V_{GS}=0V,$ $F=1.0\text{MHz}$ | | 500 | | PF |
| Output Capacitance | C_{oss} | | | 300 | | PF |
| Reverse Transfer Capacitance | C_{rss} | | | 140 | | PF |
| SWITCHING CHARACTERISTICS (Note 4) | | | | | | |
| Turn-on Delay Time | $t_{d(on)}$ | $V_{DD}=10V, I_D=1A$ $V_{GS}=4.5V, R_{GEN}=6\Omega$ | | 20 | 40 | nS |
| Turn-on Rise Time | t_r | | | 18 | 40 | nS |
| Turn-Off Delay Time | $t_{d(off)}$ | | | 60 | 108 | nS |
| Turn-Off Fall Time | t_f | | | 28 | 56 | nS |
| Total Gate Charge | Q_g | $V_{DS}=10V, I_D=5A, V_{GS}=4.5V$ | | 10 | 15 | nC |
| Gate-Source Charge | Q_{gs} | | | 2.3 | | nC |
| Gate-Drain Charge | Q_{gd} | | | 2.9 | | nC |
| DRAIN-SOURCE DIODE CHARACTERISTICS | | | | | | |
| Diode Forward Voltage (Note 3) | V_{SD} | $V_{GS}=0V, I_S=1A$ | | | 1.2 | V |
| Diode Forward Current (Note 2) | I_S | | | | 1 | A |

NOTES:

1. Repetitive Rating: Pulse width limited by maximum junction temperature.
2. Surface Mounted on FR4 Board, $t \leq 10$ sec.
3. Pulse Test: Pulse Width $\leq 300\mu\text{s}$, Duty Cycle $\leq 2\%$.
4. Guaranteed by design, not subject to production testing.

TYPICAL ELECTRICAL AND THERMAL CHARACTERISTICS

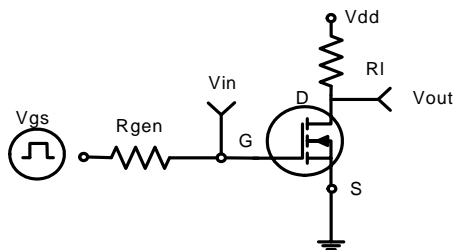

Figure 1: Switching Test Circuit

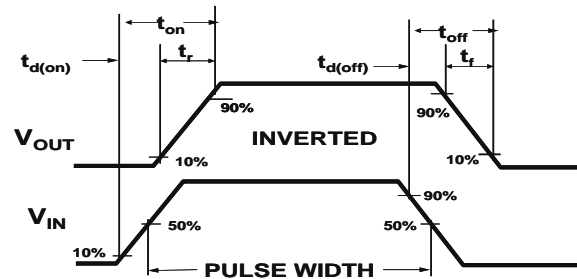
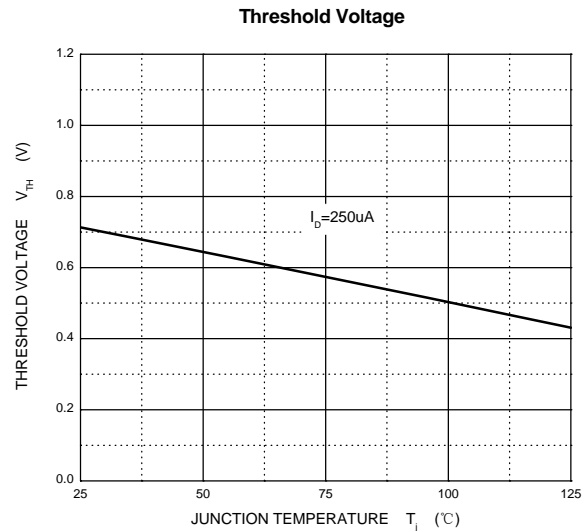
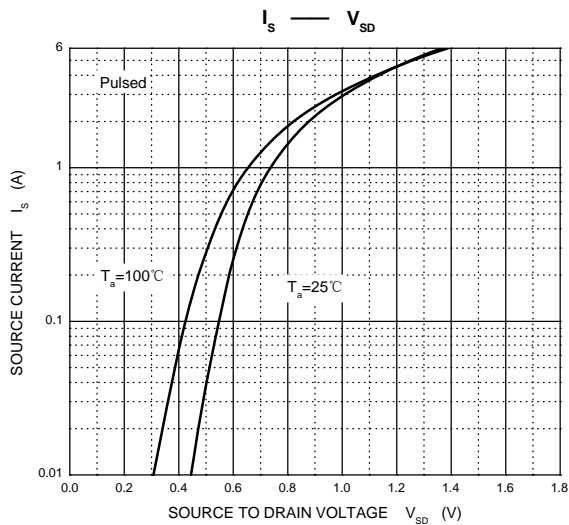
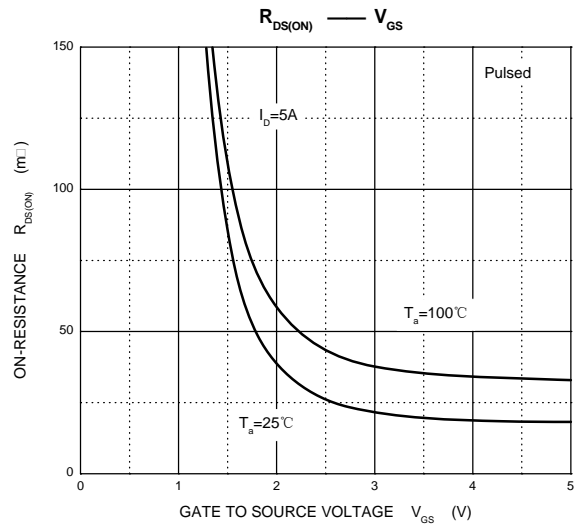
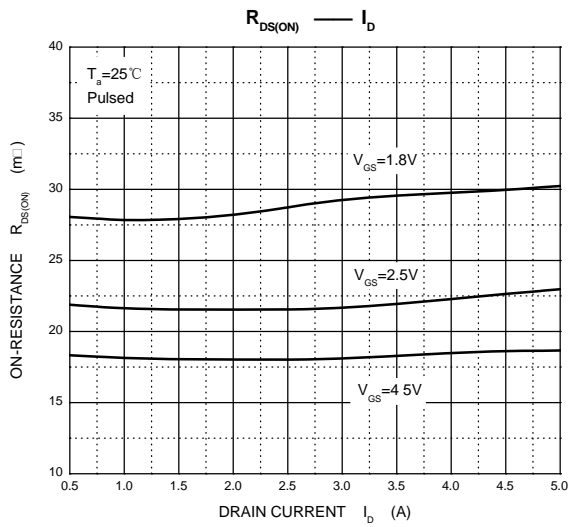
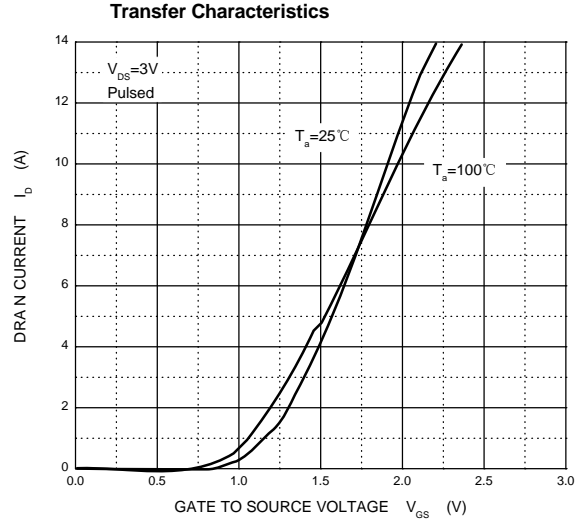
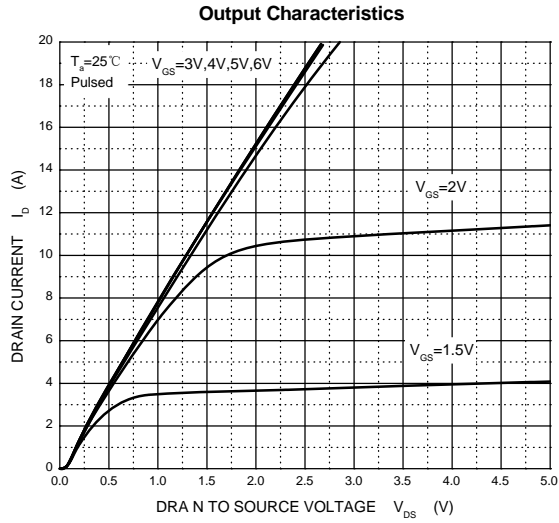
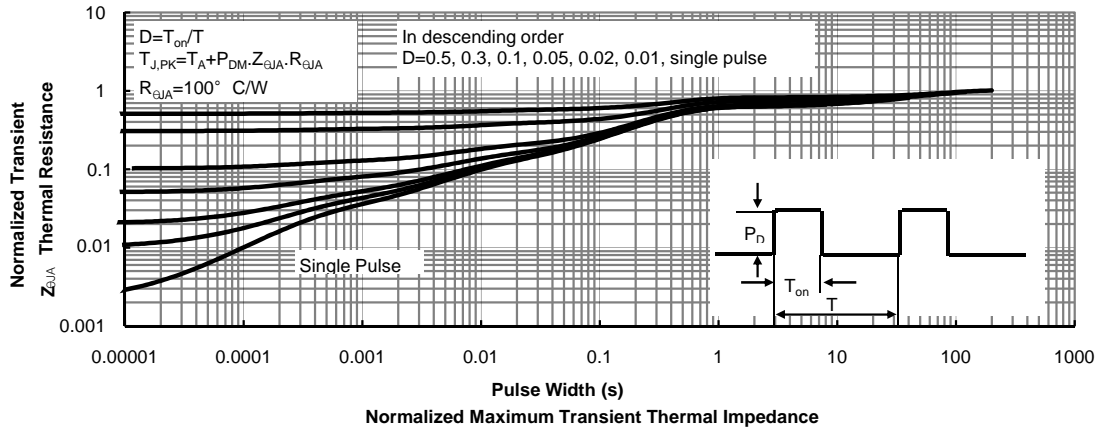

Figure 2: S switching Waveforms





SOT-23 PACKAGE INFORMATION

Dimensions in Millimeters (UNIT:mm)

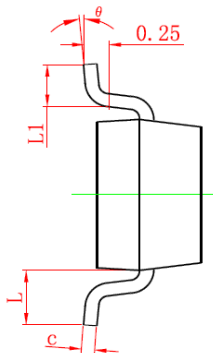
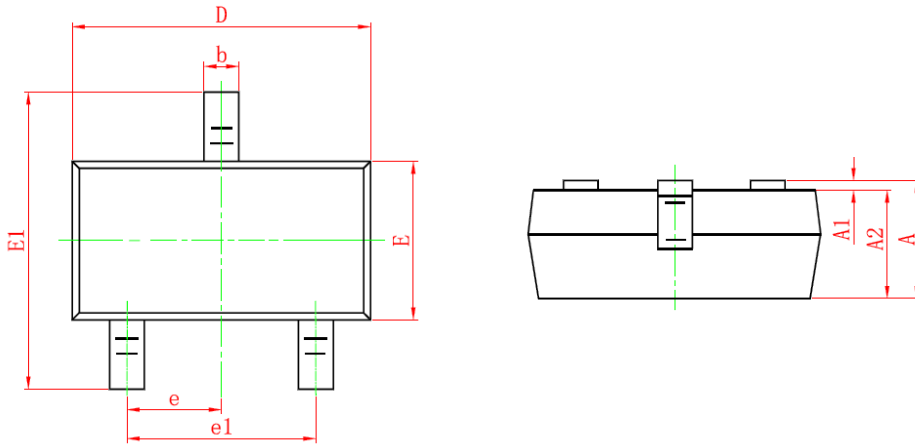

| Symbol | Dimensions in Millimeters | |
|--------|---------------------------|-------|
| | MIN. | MAX. |
| A | 0.900 | 1.150 |
| A1 | 0.000 | 0.100 |
| A2 | 0.900 | 1.050 |
| b | 0.300 | 0.500 |
| c | 0.080 | 0.150 |
| D | 2.800 | 3.000 |
| E | 1.200 | 1.400 |
| E1 | 2.250 | 2.550 |
| e | 0.950TYP | |
| e1 | 1.800 | 2.000 |
| L | 0.550REF | |
| L1 | 0.300 | 0.500 |
| θ | 0° | 8° |

NOTES

- All dimensions are in millimeters.
- Tolerance $\pm 0.10\text{mm}$ (4 mil) unless otherwise specified
- Package body sizes exclude mold flash and gate burrs. Mold flash at the non-lead sides should be less than 5 mils.
- Dimension L is measured in gauge plane.
- Controlling dimension is millimeter, converted inch dimensions are not necessarily exact.