

30V N-Channel Enhancement-Mode MOSFET

1. FEATURES

- VDS= 30V
- RDS(ON), VGS@10V, IDS@5.8A = 38mΩ
- RDS(ON), VGS@4.5V, IDS@5.0A = 43mΩ
- RDS(ON), VGS@2.5V, IDS@4.0A = 62mΩ
- We declare that the material of product compliance with RoHS requirements and Halogen Free.

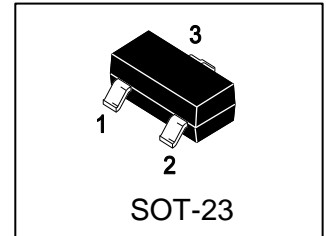

2. APPLICATIONS

- Advanced trench process technology
- High density cell design for ultra low on-resistance

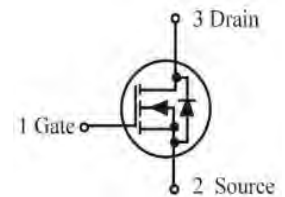

3. DEVICE MARKING AND ORDERING INFORMATION

Device	Marking	Shipping
FTK2306L	N06	3000/Tape&Reel

4. MAXIMUM RATINGS(Ta = 25°C)

Parameter	Symbol	Limits	Unit
Drain-Source Voltage	VDSS	30	V
Gate-to-Source Voltage – Continuous	VGS	±12	V
Drain Current			A
– Continuous TA = 25°C	ID	5.8	
– Pulsed(Note 1)	IDM	30	

5. THERMAL CHARACTERISTICS

Parameter	Symbol	Limits	Unit
Maximum Power Dissipation	PD	1.4	W
Thermal Resistance, Junction-to-Ambient(Note 2)	RθJA	140	°C/W
Junction and Storage temperature	TJ,Tstg	-55~+150	°C

1. Repetitive Rating: Pulse width limited by the Maximum junction temperature.
2. 1-in² 2oz Cu PCB board.



FTK2306L

6. ELECTRICAL CHARACTERISTICS (Ta= 25°C)

OFF CHARACTERISTICS

Characteristic	Symbol	Min.	Typ.	Max.	Unit
Drain-Source Breakdown Voltage (VGS = 0, ID = 250 μ Adc)	V(BR)DSS	30	-	-	Vdc
Zero Gate Voltage Drain Current (VDS=9.6V, VGS=0V)	IDSS	-	-	1	μ Adc
Gate-Body Leakage Current, Forward (VDS = 0 V, VGS = 8 V)	IGSSF	-	-	100	nAdc
Gate-Body Leakage Current, Reverse (VDS = 0 V, VGS = -8 V)	IGSSR	-	-	-100	nAdc
Forward Transconductance (VDS = 5.0 V, ID = 5 A)	gfs	10	15	-	S

ON CHARACTERISTICS (Note 3)

Characteristic	Symbol	Min.	Typ.	Max.	Unit
Gate Threshold Voltage (VDS = VGS, ID = 250 μ Adc)	VGS(th)	0.7	-	1.4	Vdc
Static Drain-Source On-State Resistance (VGS = 10 V, ID =5.8 A) (VGS = 4.5 V, ID =5 A) (VGS = 2.5 V, ID = 4 A)	RDS(on)	-	31 34 45	38 43 62	m Ω

DYNAMIC CHARACTERISTICS

Characteristic	Symbol	Min.	Typ.	Max.	Unit
Input Capacitance (VGS = 0 V, f = 1.0MHz, VDS= 15 V)	Ciss	-	513.51	-	pF
Output Capacitance (VGS = 0 V, f = 1.0MHz, VDS= 15 V)	Coss	-	80.85	-	pF
Reverse Transfer Capacitance (VGS = 0 V, f = 1.0MHz, VDS= 15 V)	Crss	-	54.87	-	pF

SWITCHING CHARACTERISTICS

Characteristic	Symbol	Min.	Typ.	Max.	Unit
Turn-On Delay Time	td(on)	-	7	14	ns
Rise Time	tr	-	15	30	
Turn-Off Delay Time	td(off)	-	38	76	
Fall Time	tf	-	3	6	

(VDD = 15V, RL = 2.7 Ω , ID = 1A, VGEN = 10V, RG = 3 Ω)

SOURCE-DRAIN DIODE CHARACTERISTICS

Characteristic	Symbol	Min.	Typ.	Max.	Unit
Forward Voltage (VGS = 0 Vdc, ISD = 1 Adc)	VSD	-	-	1.2	V

3.Pulse Test: Pulse Width \leq 300 μ s, Duty Cycle \leq 2.0%.



TYPICAL ELECTRICAL CHARACTERISTICS

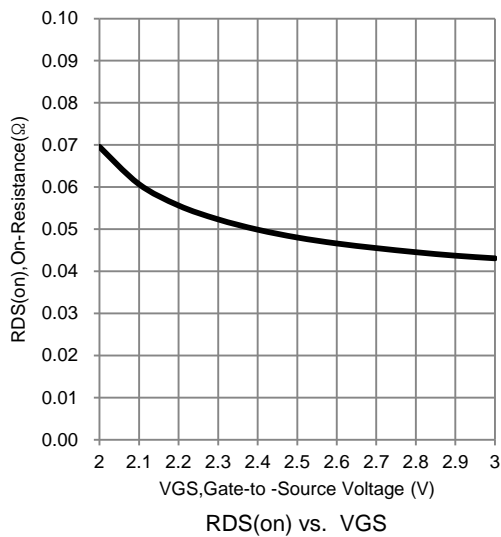
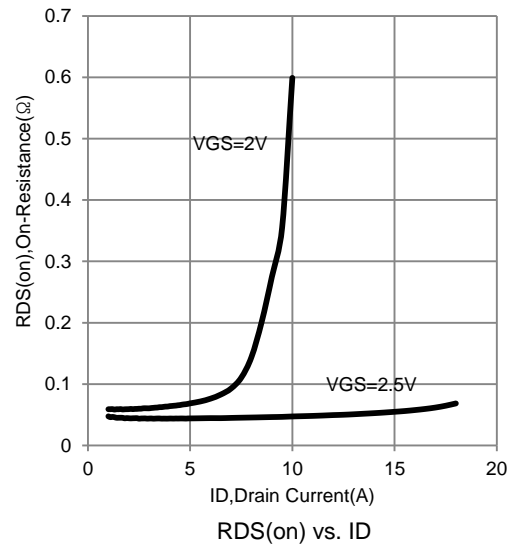
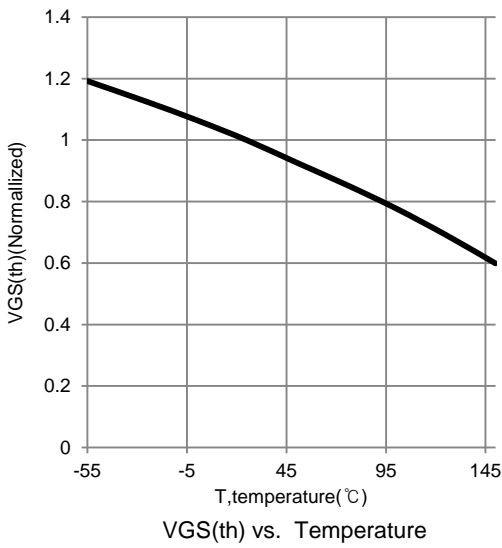
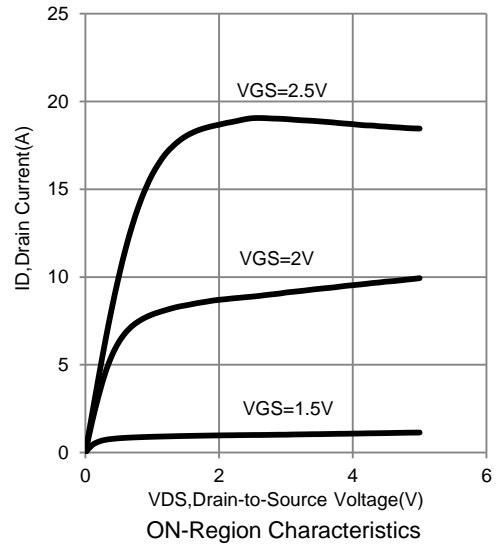
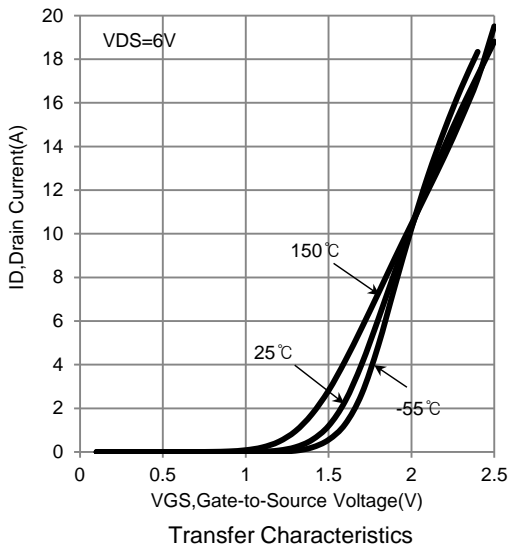

SOT-23 PACKAGE INFORMATION

Notes:

1. DIMENSIONING AND TOLERANCING PER ANSI Y14.5M, 1982.
2. CONTROLLING DIMENSION: MILLIMETERS.
3. MAXIMUM LEAD THICKNESS INCLUDES LEAD FINISH. MINIMUM LEAD THICKNESS IS THE MINIMUM THICKNESS OF BASE MATERIAL.
4. DIMENSIONS D AND E DO NOT INCLUDE MOLD FLASH, PROTRUSIONS OR GATE BURRS.

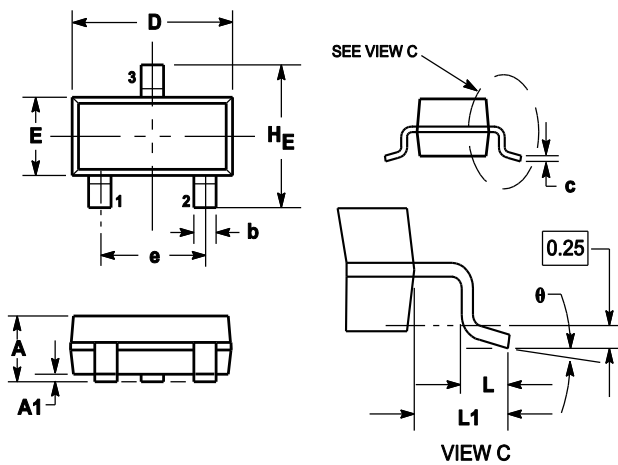

DIM	MILLIMETERS			INCHES		
	MIN	NOM	MAX	MIN	NOM	MAX
A	0.89	1	1.11	0.035	0.04	0.044
A1	0.01	0.06	0.1	0.001	0.002	0.004
b	0.37	0.44	0.5	0.015	0.018	0.02
c	0.09	0.13	0.18	0.003	0.005	0.007
D	2.80	2.9	3.04	0.11	0.114	0.12
E	1.20	1.3	1.4	0.047	0.051	0.055
e	1.78	1.9	2.04	0.07	0.075	0.081
L	0.10	0.2	0.3	0.004	0.008	0.012
L1	0.35	0.54	0.69	0.014	0.021	0.029
HE	2.10	2.4	2.64	0.083	0.094	0.104
θ	0°	---	10°	0°	---	10°

SOLDERING FOOTPRINT

