

## 40V P-Channel MOSFETs

### General Description

These P-Channel enhancement mode power field effect transistors are using trench DMOS technology. This advanced technology has been especially tailored to minimize on-state resistance, provide superior switching performance, and withstand high energy pulse in the avalanche and commutation mode. These devices are well suited for high efficiency fast switching applications.

BVDSS	RDSON	ID
-40V	45mΩ	-16A

### Features

- -40V,-16A,  $R_{DS(ON)} = 45m\Omega @ V_{GS} = -10V$
- Improved  $dv/dt$  capability
- Fast switching
- Green Device Available

### TO252 Pin Configuration

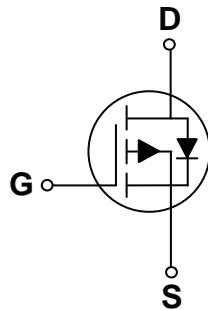
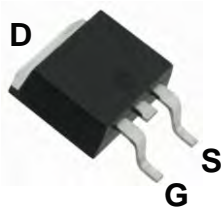

### Applications

- Motor Drive
- Power Tools
- LED Lighting

### Absolute Maximum Ratings $T_c=25^\circ\text{C}$ unless otherwise noted

Symbol	Parameter	Rating	Units
$V_{DS}$	Drain-Source Voltage	-40	V
$V_{GS}$	Gate-Source Voltage	$\pm 20$	V
$I_D$	Drain Current – Continuous ( $T_c=25^\circ\text{C}$ )	-16	A
	Drain Current – Continuous ( $T_c=100^\circ\text{C}$ )	-10	A
$I_{DM}$	Drain Current – Pulsed <sup>1</sup>	-64	A
EAS	Single Pulse Avalanche Energy <sup>2</sup>	31	mJ
IAS	Single Pulse Avalanche Current <sup>2</sup>	25	A
$P_D$	Power Dissipation ( $T_c=25^\circ\text{C}$ )	32.9	W
	Power Dissipation – Derate above $25^\circ\text{C}$	0.26	W/ $^\circ\text{C}$
$T_{STG}$	Storage Temperature Range	-50 to 150	$^\circ\text{C}$
$T_J$	Operating Junction Temperature Range	-50 to 150	$^\circ\text{C}$

### Thermal Characteristics

Symbol	Parameter	Typ.	Max.	Unit
$R_{\theta JA}$	Thermal Resistance Junction to ambient	---	62	$^\circ\text{C}/\text{W}$
$R_{\theta JC}$	Thermal Resistance Junction to Case	---	3.8	$^\circ\text{C}/\text{W}$



# FTK4909D

## 40V P-Channel MOSFETs

Electrical Characteristics ( $T_J=25\text{ }^\circ\text{C}$ , unless otherwise noted)

### Off Characteristics

Symbol	Parameter	Conditions	Min.	Typ.	Max.	Unit
$BV_{DSS}$	Drain-Source Breakdown Voltage	$V_{GS}=0V, I_D=-250\mu A$	-40	---	---	V
$\Delta BV_{DSS}/\Delta T_J$	$BV_{DSS}$ Temperature Coefficient	Reference to $25\text{ }^\circ\text{C}$ , $I_D=-1mA$	---	-0.05	---	V/ $^\circ\text{C}$
$I_{DSS}$	Drain-Source Leakage Current	$V_{DS}=-40V, V_{GS}=0V, T_J=25\text{ }^\circ\text{C}$	---	---	-1	$\mu A$
		$V_{DS}=-32V, V_{GS}=0V, T_J=125\text{ }^\circ\text{C}$	---	---	-10	$\mu A$
$I_{GSS}$	Gate-Source Leakage Current	$V_{GS}=\pm 20V, V_{DS}=0V$	---	---	$\pm 100$	nA

### On Characteristics

$R_{DS(ON)}$	Static Drain-Source On-Resistance	$V_{GS}=-10V, I_D=-10A$	---	37	45	m $\Omega$
		$V_{GS}=-4.5V, I_D=-6A$	---	57	68	m $\Omega$
$V_{GS(th)}$	Gate Threshold Voltage	$V_{GS}=V_{DS}, I_D=-250\mu A$	-1.2	-1.6	-2.5	V
$\Delta V_{GS(th)}$	$V_{GS(th)}$ Temperature Coefficient		---	5	---	mV/ $^\circ\text{C}$
gfs	Forward Transconductance	$V_{DS}=-10V, I_D=-5A$	---	7	---	S

### Dynamic and switching Characteristics

$Q_g$	Total Gate Charge <sup>3,4</sup>	$V_{DS}=-20V, V_{GS}=-4.5V, I_D=-5A$	---	8.2	16	nC
$Q_{gs}$	Gate-Source Charge <sup>3,4</sup>		---	3.0	6	
$Q_{gd}$	Gate-Drain Charge <sup>3,4</sup>		---	2.5	5	
$T_{d(on)}$	Turn-On Delay Time <sup>3,4</sup>	$V_{DD}=-20V, V_{GS}=-10V, R_G=6\Omega$ $I_D=-1A$	---	6.3	12	ns
$T_r$	Rise Time <sup>3,4</sup>		---	7.2	14	
$T_{d(off)}$	Turn-Off Delay Time <sup>3,4</sup>		---	46	80	
$T_f$	Fall Time <sup>3,4</sup>		---	14	27	
$C_{iss}$	Input Capacitance	$V_{DS}=-25V, V_{GS}=0V, F=1MHz$	---	825	1480	pF
$C_{oss}$	Output Capacitance		---	68	130	
$C_{riss}$	Reverse Transfer Capacitance		---	50	100	

### Drain - Source Diode Characteristics and Maximum Ratings

Symbol	Parameter	Conditions	Min.	Typ.	Max.	Unit
$I_S$	Continuous Source Current	$V_G=V_D=0V$ , Force Current	---	---	-16	A
$I_{SM}$	Pulsed Source Current		---	---	-32	A
$V_{SD}$	Diode Forward Voltage	$V_{GS}=0V, I_S=-1A, T_J=25\text{ }^\circ\text{C}$	---	---	-1	V

Note :

1. Repetitive Rating : Pulsed width limited by maximum junction temperature.
2.  $V_{DD}=25V, V_{GS}=10V, L=0.1mH, I_{AS}=25A$ ., Starting  $T_J=25\text{ }^\circ\text{C}$
3. The data tested by pulsed , pulse width  $\leq 300\mu s$  , duty cycle  $\leq 2\%$ .
4. Essentially independent of operating temperature.

## 40V P-Channel MOSFETs

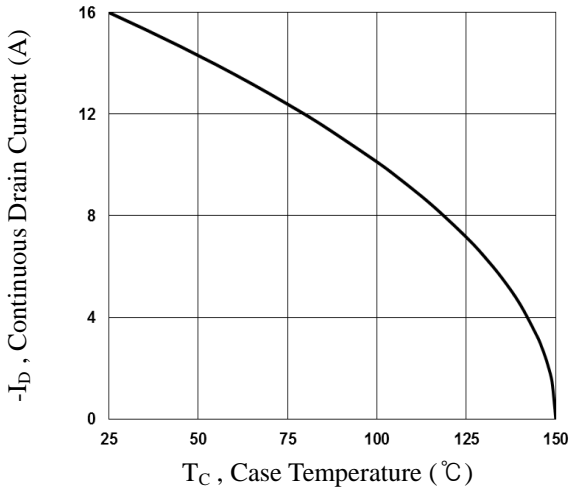

Fig.1 Continuous Drain Current vs.  $T_C$

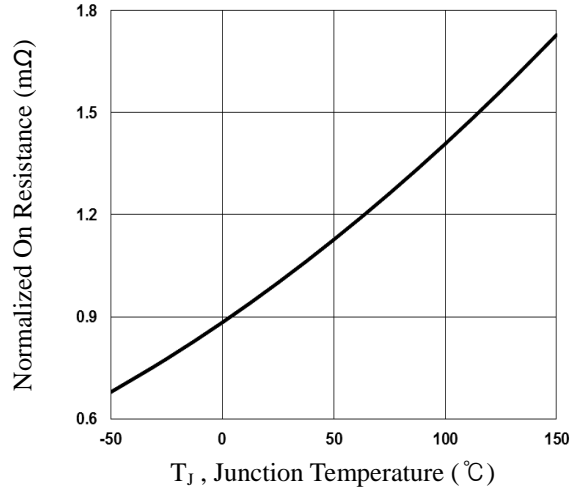

Fig.2 Normalized  $R_{DS(on)}$  vs.  $T_J$

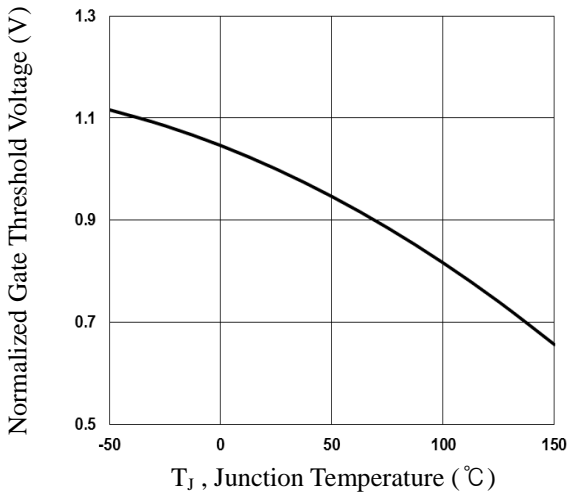

Fig.3 Normalized  $V_{th}$  vs.  $T_J$

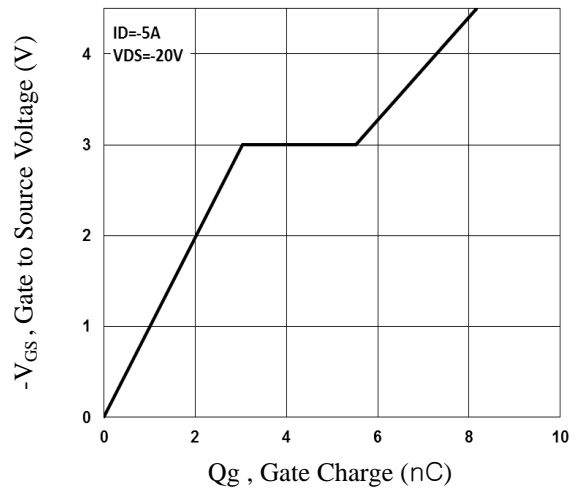

Fig.4 Gate Charge Waveform

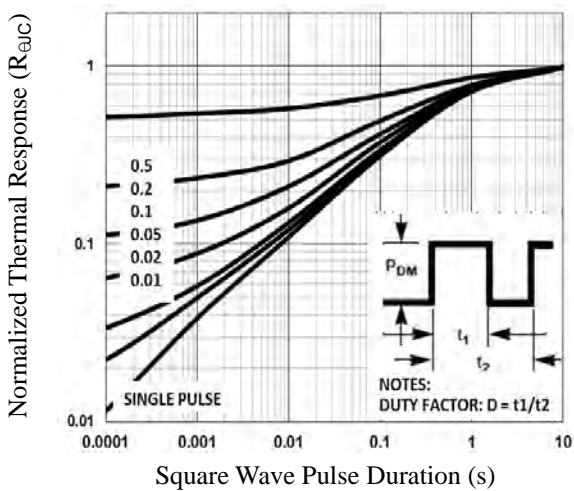

Fig.5 Normalized Transient Impedance

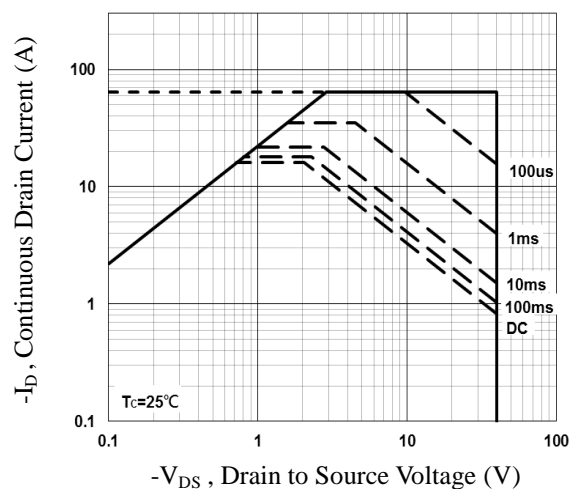

Fig.6 Maximum Safe Operation Area

## 40V P-Channel MOSFETs

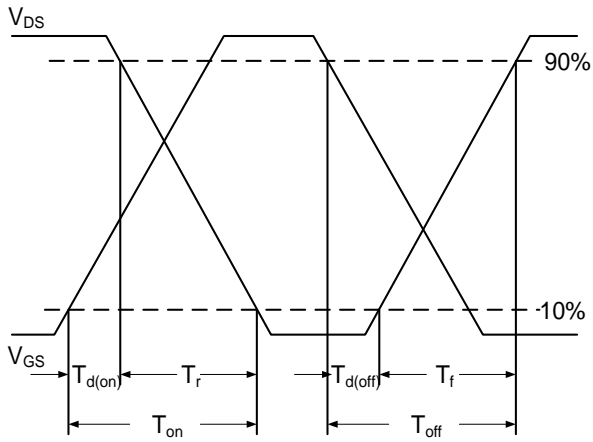

Fig.7 Switching Time Waveform

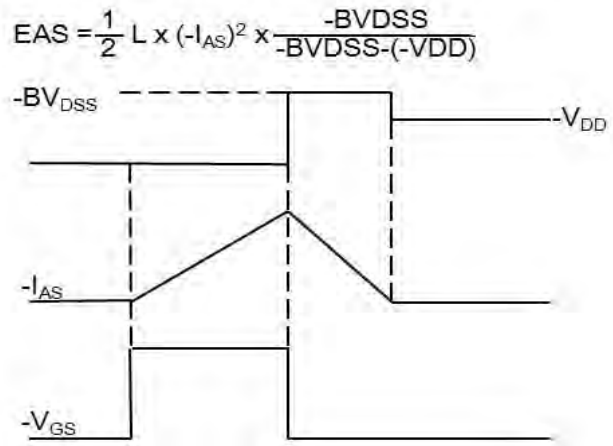
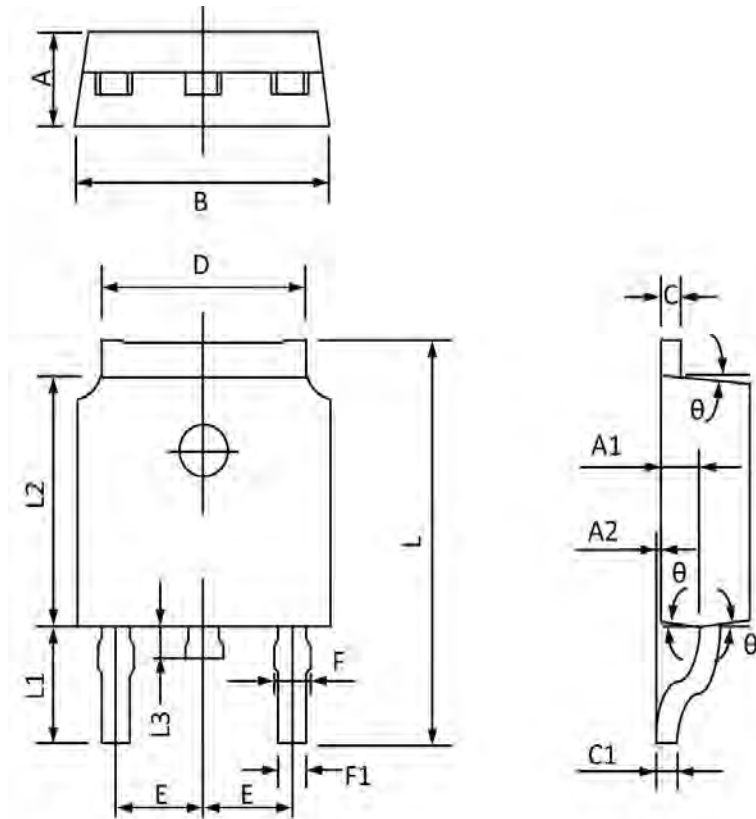

Fig.8 EAS Waveform

## 40V P-Channel MOSFETs

### TO252 PACKAGE INFORMATION



Symbol	Dimensions In Millimeters		Dimensions In Inches	
	MAX	MIN	MAX	MIN
A	2.400	2.200	0.094	0.087
A1	1.110	0.910	0.044	0.036
A2	0.150	0.000	0.006	0.000
B	6.800	6.400	0.268	0.252
C	0.580	0.450	0.023	0.018
C1	0.580	0.460	0.023	0.018
D	5.500	5.100	0.217	0.201
E	2.386	2.186	0.094	0.086
F	0.940	0.600	0.037	0.024
F1	0.860	0.500	0.034	0.020
L	10.400	9.400	0.409	0.370
L1	3.000	2.400	0.118	0.094
L2	6.200	5.400	0.244	0.213
L3	1.200	0.600	0.047	0.024
θ	9°	3°	9°	3°