

### 30V N-Channel MOSFETs

#### General Description

These N-Channel enhancement mode power field effect transistors are using trench DMOS technology. This advanced technology has been especially tailored to minimize on-state resistance, provide superior switching performance, and withstand high energy pulse in the avalanche and commutation mode. These devices are well suited for high efficiency fast switching applications.

BVDSS	RDSON	ID
30V	2.4mΩ	150A

#### Features

- 30V, 150A,  $R_{DS(ON)} = 2.4m\Omega @ V_{GS} = 10V$
- Improved  $dv/dt$  capability
- Fast switching
- 100% EAS Guaranteed
- Green Device Available

#### PPAK5X6 Pin Configuration

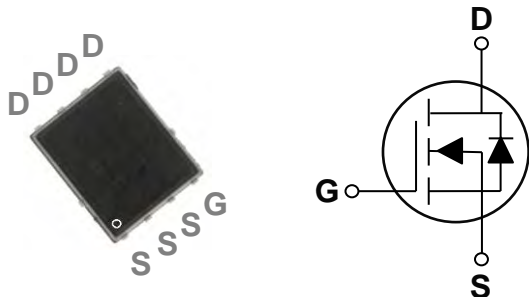

#### Applications

- Networking
- Load Switch
- LED applications

#### Absolute Maximum Ratings ( $T_c=25^\circ\text{C}$ unless otherwise noted)

Symbol	Parameter	Rating	Units
$V_{DS}$	Drain-Source Voltage	30	V
$V_{GS}$	Gate-Source Voltage	$\pm 20$	V
$I_D$	Drain Current – Continuous ( $T_c=25^\circ\text{C}$ )	150	A
	Drain Current – Continuous ( $T_c=100^\circ\text{C}$ )	95	A
$I_{DM}$	Drain Current – Pulsed <sup>1</sup>	600	A
EAS	Single Pulse Avalanche Energy <sup>2</sup>	288	mJ
IAS	Single Pulse Avalanche Current <sup>2</sup>	76	A
$P_D$	Power Dissipation ( $T_c=25^\circ\text{C}$ )	122	W
	Power Dissipation – Derate above $25^\circ\text{C}$	0.98	W/ $^\circ\text{C}$
$T_{STG}$	Storage Temperature Range	-50 to 150	$^\circ\text{C}$
$T_J$	Operating Junction Temperature Range	-50 to 150	$^\circ\text{C}$

#### Thermal Characteristics

Symbol	Parameter	Typ.	Max.	Unit
$R_{\theta JA}$	Thermal Resistance Junction to ambient	---	62	$^\circ\text{C}/\text{W}$
$R_{\theta JC}$	Thermal Resistance Junction to Case	---	1.02	$^\circ\text{C}/\text{W}$



# FTK3984DFN56

## 30V N-Channel MOSFETs

Electrical Characteristics ( $T_J=25\text{ }^\circ\text{C}$ , unless otherwise noted)

### Off Characteristics

Symbol	Parameter	Conditions	Min.	Typ.	Max.	Unit
$BV_{DSS}$	Drain-Source Breakdown Voltage	$V_{GS}=0V, I_D=250\mu A$	30	---	---	V
$\Delta BV_{DSS}/\Delta T_J$	$BV_{DSS}$ Temperature Coefficient	Reference to $25\text{ }^\circ\text{C}$ , $I_D=1mA$	---	0.02	---	V/ $^\circ\text{C}$
$I_{DSS}$	Drain-Source Leakage Current	$V_{DS}=30V, V_{GS}=0V, T_J=25\text{ }^\circ\text{C}$	---	---	1	$\mu A$
		$V_{DS}=24V, V_{GS}=0V, T_J=125\text{ }^\circ\text{C}$	---	---	10	$\mu A$
$I_{GSS}$	Gate-Source Leakage Current	$V_{GS}=\pm 20V, V_{DS}=0V$	---	---	$\pm 100$	nA

### On Characteristics

$R_{DS(ON)}$	Static Drain-Source On-Resistance	$V_{GS}=10V, I_D=30A$	---	1.95	2.4	m $\Omega$
		$V_{GS}=4.5V, I_D=20A$	---	2.6	3.3	m $\Omega$
$V_{GS(th)}$	Gate Threshold Voltage	$V_{GS}=V_{DS}, I_D=250\mu A$	1.2	1.6	2.5	V
$\Delta V_{GS(th)}$	$V_{GS(th)}$ Temperature Coefficient		---	-4.82	---	mV/ $^\circ\text{C}$
gfs	Forward Transconductance	$V_{DS}=10V, I_D=10A$	---	28	---	S

### Dynamic and switching Characteristics

$Q_g$	Total Gate Charge <sup>3, 4</sup>	$V_{DS}=15V, V_{GS}=10V, I_D=30A$	---	56.4	110	nC
$Q_{gs}$	Gate-Source Charge <sup>3, 4</sup>		---	13.8	27	
$Q_{gd}$	Gate-Drain Charge <sup>3, 4</sup>		---	6.4	13	
$T_{d(on)}$	Turn-On Delay Time <sup>3, 4</sup>	$V_{DD}=15V, V_{GS}=10V, R_G=3.3\Omega$ $I_D=1A$	---	18.7	37	ns
$T_r$	Rise Time <sup>3, 4</sup>		---	25.4	50	
$T_{d(off)}$	Turn-Off Delay Time <sup>3, 4</sup>		---	64	120	
$T_f$	Fall Time <sup>3, 4</sup>		---	22.6	45	
$C_{iss}$	Input Capacitance	$V_{DS}=15V, V_{GS}=0V, F=1MHz$	---	3800	7600	pF
$C_{oss}$	Output Capacitance		---	565	1100	
$C_{rss}$	Reverse Transfer Capacitance		---	320	640	
$R_g$	Gate resistance	$V_{GS}=0V, V_{DS}=0V, F=1MHz$	---	2.1	---	$\Omega$

### Drain-Source Diode Characteristics and Maximum Ratings

Symbol	Parameter	Conditions	Min.	Typ.	Max.	Unit
$I_S$	Continuous Source Current	$V_G=V_D=0V$ , Force Current	---	---	150	A
$I_{SM}$	Pulsed Source Current		---	---	300	A
$V_{SD}$	Diode Forward Voltage	$V_{GS}=0V, I_S=1A, T_J=25\text{ }^\circ\text{C}$	---	---	1	V

Note :

1. Repetitive Rating : Pulsed width limited by maximum junction temperature.
2.  $V_{DD}=25V, V_{GS}=10V, L=0.1mH, I_{AS}=76A, R_G=25\Omega$ , Starting  $T_J=25\text{ }^\circ\text{C}$ .
3. The data tested by pulsed, pulse width  $\leq 300\mu s$ , duty cycle  $\leq 2\%$ .
4. Essentially independent of operating temperature.

## 30V N-Channel MOSFETs

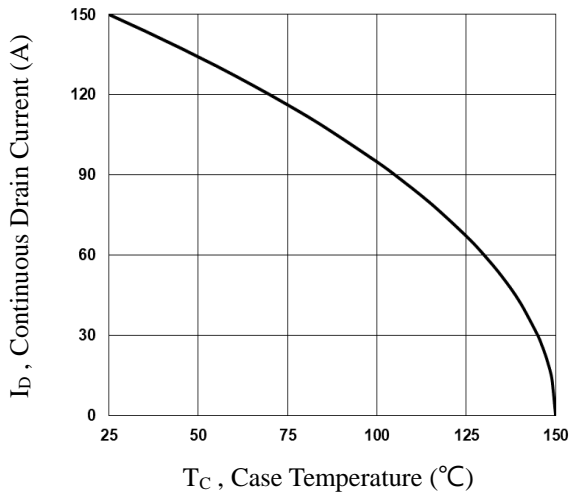

Fig.1 Continuous Drain Current vs. TC

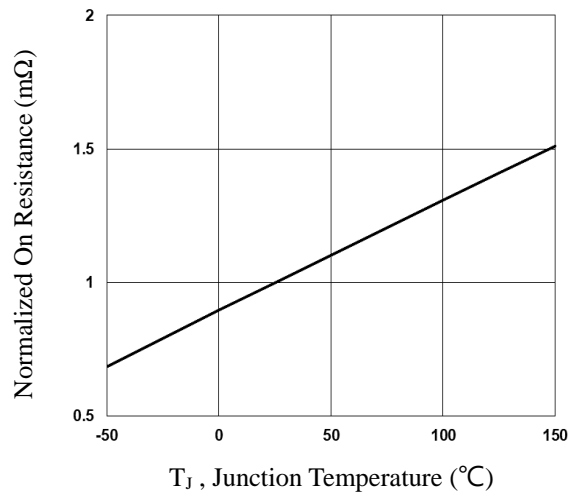

Fig.2 Normalized RDS(on) vs. TJ

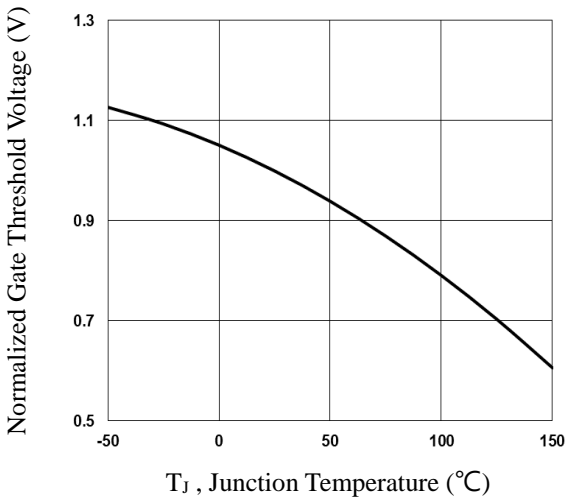

Fig.3 Normalized Vth vs. TJ

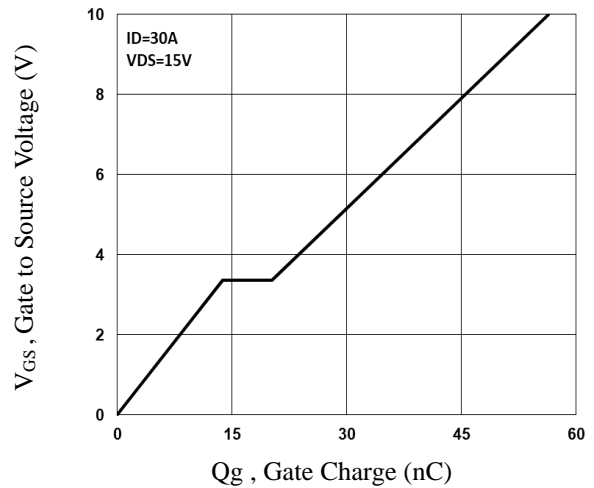

Fig.4 Gate Charge Characteristics

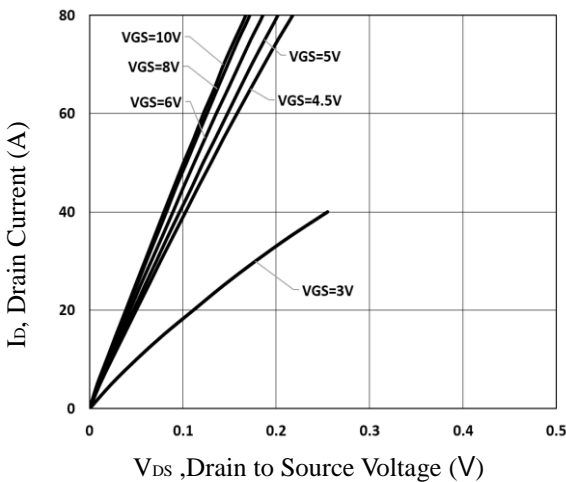

Fig.5 Typical Output Characteristics

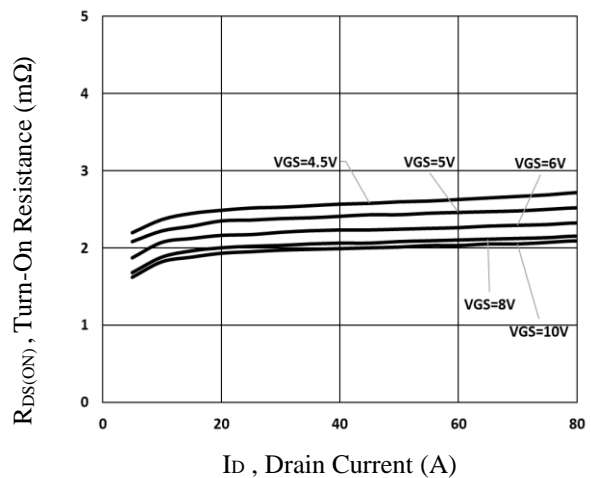
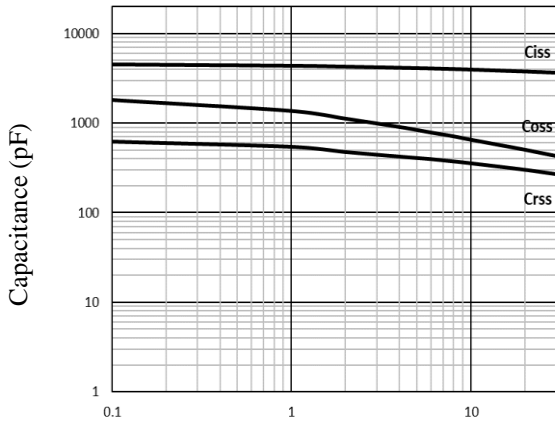

Fig.6 Turn-On Resistance vs. ID

## 30V N-Channel MOSFETs



$V_{DS}$ , Drain to Source Voltage (V)

Fig.7 Capacitance Characteristics

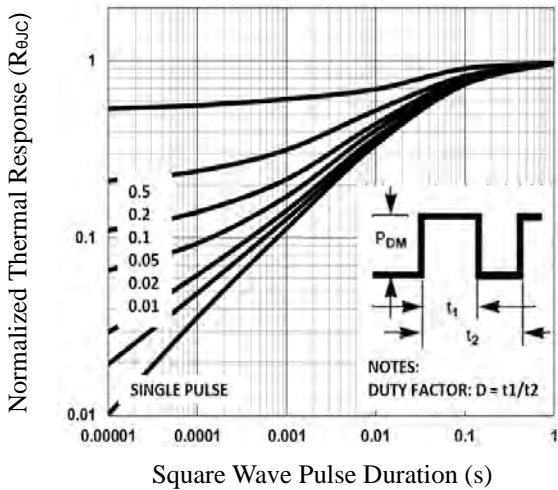

Square Wave Pulse Duration (s)

Fig.8 Normalized Transient Impedance

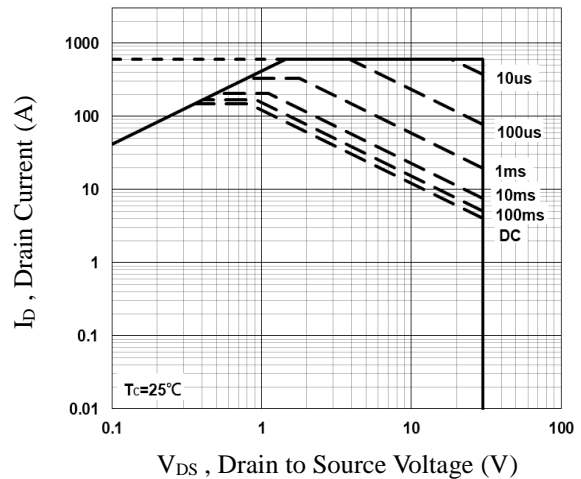

$V_{DS}$ , Drain to Source Voltage (V)

Fig.9 Maximum Safe Operation Area

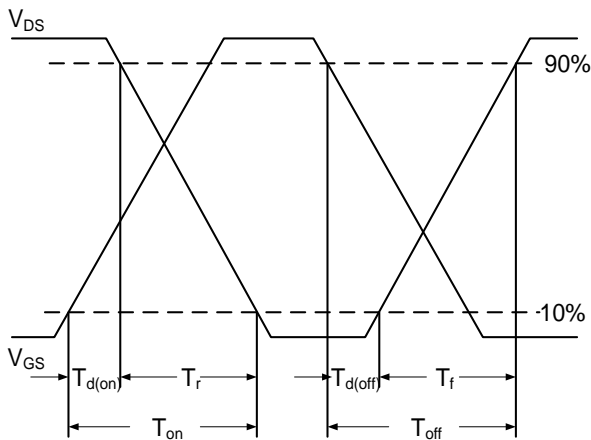

Fig.10 Switching Time Waveform

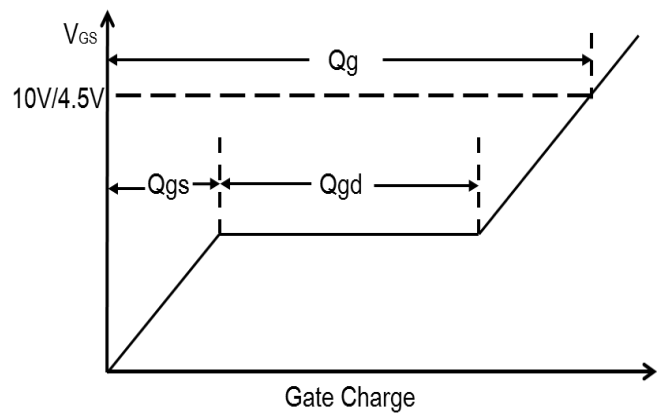
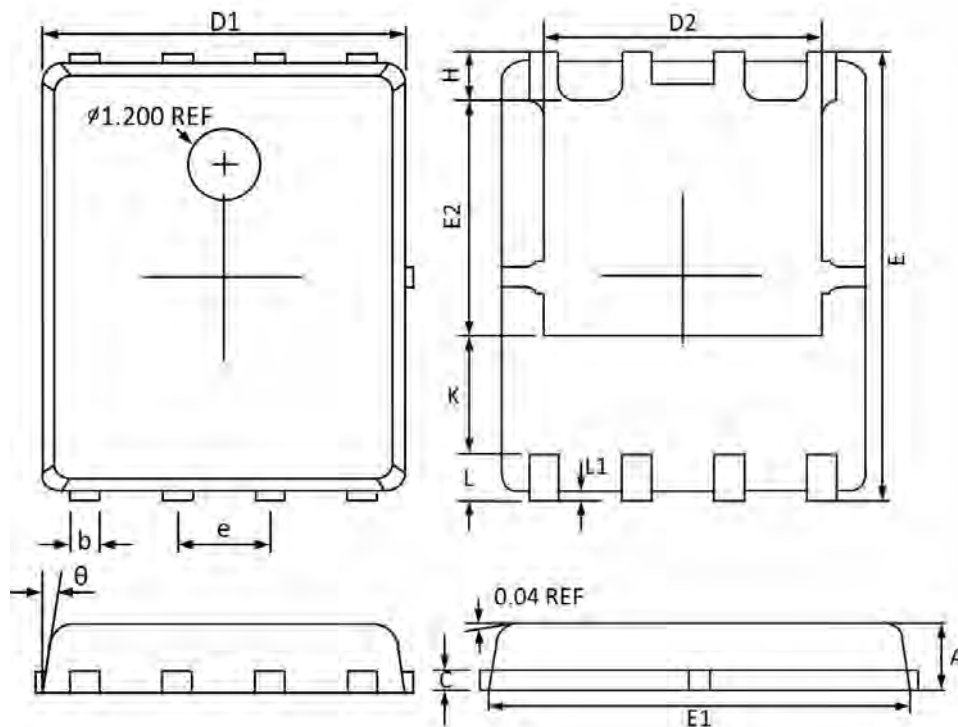

Fig.11 Gate Charge Waveform

30V N-Channel MOSFETs

## PPAK5X6 PACKAGE INFORMATION



Symbol	Dimensions In Millimeters		Dimensions In Inches	
	MAX	MIN	MAX	MIN
A	1.100	0.800	0.043	0.031
b	0.510	0.330	0.020	0.013
C	0.300	0.200	0.012	0.008
D1	5.100	4.800	0.201	0.189
D2	4.100	3.610	0.161	0.142
E	6.200	5.900	0.244	0.232
E1	5.900	5.700	0.232	0.224
E2	3.780	3.350	0.149	0.132
e	1.27BSC		0.05BSC	
H	0.700	0.410	0.028	0.016
K	1.500	1.100	0.059	0.043
L	0.710	0.510	0.028	0.020
L1	0.200	0.060	0.008	0.002
θ	12°	0°	12°	0°