

## 30V P-Channel MOSFETs

### General Description

These P-Channel enhancement mode power field effect transistors are using trench DMOS technology. This advanced technology has been especially tailored to minimize on-state resistance, provide superior switching performance, and withstand high energy pulse in the avalanche and commutation mode. These devices are well suited for high efficiency fast switching applications.

BVDSS	RDSON	ID
-30V	50mΩ	-5.5A

### Features

- -30V,-5.5A,  $R_{DS(ON)} = 50m\Omega @ V_{GS} = -10V$
- Fast switching
- Green Device Available
- Suit for -4.5V Gate Drive Applications

### SOP-8 Pin Configuration

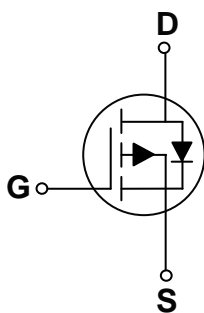
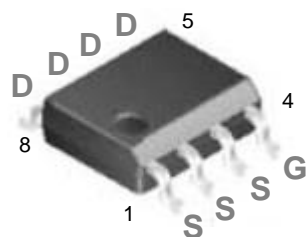

### Applications

- Notebook
- Load Switch
- Battery Protection
- Hand-held Instruments

### Absolute Maximum Ratings ( $T_c=25^\circ\text{C}$ unless otherwise noted)

Symbol	Parameter	Rating	Units
$V_{DS}$	Drain-Source Voltage	-30	V
$V_{GS}$	Gate-Source Voltage	$\pm 20$	V
$I_D$	Drain Current – Continuous ( $T_c=25^\circ\text{C}$ )	-5.5	A
	Drain Current – Continuous ( $T_c=100^\circ\text{C}$ )	-3.48	A
$I_{DM}$	Drain Current – Pulsed <sup>1</sup>	-22	A
$P_D$	Power Dissipation ( $T_c=25^\circ\text{C}$ )	2.1	W
	Power Dissipation – Derate above $25^\circ\text{C}$	0.017	W/ $^\circ\text{C}$
$T_{STG}$	Storage Temperature Range	-55 to 150	$^\circ\text{C}$
$T_J$	Operating Junction Temperature Range	-55 to 150	$^\circ\text{C}$

### Thermal Characteristics

Symbol	Parameter	Typ.	Max.	Unit
$R_{\theta JA}$	Thermal Resistance Junction to ambient	---	60	$^\circ\text{C}/\text{W}$

## 30V P-Channel MOSFETs

Electrical Characteristics ( $T_J=25^\circ\text{C}$ , unless otherwise noted)

### Off Characteristics

Symbol	Parameter	Conditions	Min.	Typ.	Max.	Unit
$BV_{DSS}$	Drain-Source Breakdown Voltage	$V_{GS}=0V, I_D=-250\mu A$	-30	---	---	V
$\Delta BV_{DSS}/\Delta T_J$	$BV_{DSS}$ Temperature Coefficient	Reference to $25^\circ\text{C}$ , $I_D=-1\text{mA}$	---	-0.03	---	V/ $^\circ\text{C}$
$I_{DSS}$	Drain-Source Leakage Current	$V_{DS}=-30V, V_{GS}=0V, T_J=25^\circ\text{C}$	---	---	-1	$\mu A$
		$V_{DS}=-24V, V_{GS}=0V, T_J=125^\circ\text{C}$	---	---	-10	$\mu A$
$I_{GSS}$	Gate-Source Leakage Current	$V_{GS}=\pm 20V, V_{DS}=0V$	---	---	$\pm 100$	nA

### On Characteristics

$R_{DS(ON)}$	Static Drain-Source On-Resistance	$V_{GS}=-10V, I_D=-3A$	---	40	50	m $\Omega$
		$V_{GS}=-4.5V, I_D=-2A$	---	62	80	m $\Omega$
$V_{GS(th)}$	Gate Threshold Voltage	$V_{GS}=V_{DS}, I_D=-250\mu A$	-1.0	-1.6	-2.5	V
$\Delta V_{GS(th)}$	$V_{GS(th)}$ Temperature Coefficient		---	4	---	mV/ $^\circ\text{C}$
gfs	Forward Transconductance	$V_{DS}=-10V, I_D=-3A$	---	3.5	---	S

### Dynamic and switching Characteristics

$Q_g$	Total Gate Charge <sup>2,3</sup>	$V_{DS}=-15V, V_{GS}=-4.5V, I_D=-3A$	---	5.1	7	nC
$Q_{gs}$	Gate-Source Charge <sup>2,3</sup>		---	2	3	
$Q_{gd}$	Gate-Drain Charge <sup>2,3</sup>		---	2.2	4	
$T_{d(on)}$	Turn-On Delay Time <sup>2,3</sup>	$V_{DD}=-15V, V_{GS}=-10V, R_G=6\Omega, I_D=-1A$	---	3.4	6	ns
$T_r$	Rise Time <sup>2,3</sup>		---	10.8	21	
$T_{d(off)}$	Turn-Off Delay Time <sup>2,3</sup>		---	26.9	51	
$T_f$	Fall Time <sup>2,3</sup>		---	6.9	13	
$C_{iss}$	Input Capacitance	$V_{DS}=-15V, V_{GS}=0V, F=1\text{MHz}$	---	560	810	pF
$C_{oss}$	Output Capacitance		---	55	80	
$C_{rss}$	Reverse Transfer Capacitance		---	40	60	

### Drain-Source Diode Characteristics and Maximum Ratings

Symbol	Parameter	Conditions	Min.	Typ.	Max.	Unit
$I_S$	Continuous Source Current	$V_G=V_D=0V$ , Force Current	---	---	-5.5	A
$I_{SM}$	Pulsed Source Current		---	---	-11	A
$V_{SD}$	Diode Forward Voltage	$V_{GS}=0V, I_S=-1A, T_J=25^\circ\text{C}$	---	---	-1	V

Note :

1. Repetitive Rating : Pulsed width limited by maximum junction temperature.
2. The data tested by pulsed, pulse width  $\leq 300\mu s$ , duty cycle  $\leq 2\%$ .
3. Essentially independent of operating temperature.

## 30V P-Channel MOSFETs

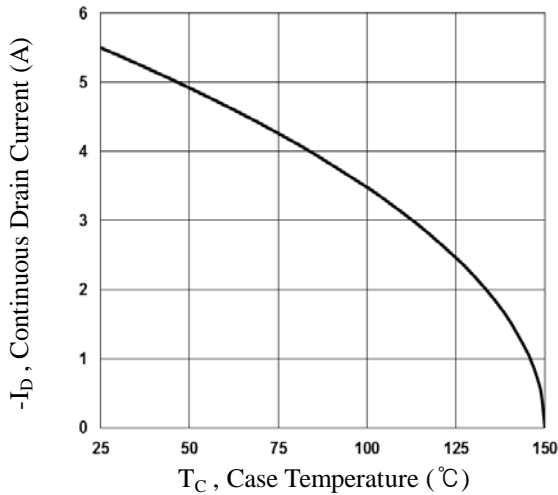

Fig.1 Continuous Drain Current vs.  $T_C$

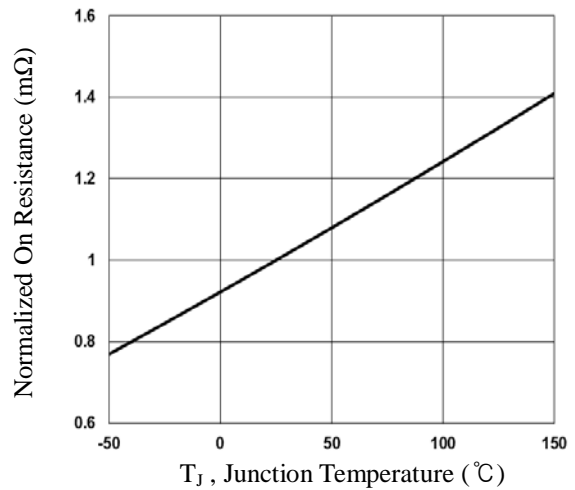

Fig.2 Normalized  $R_{DS(on)}$  vs.  $T_J$

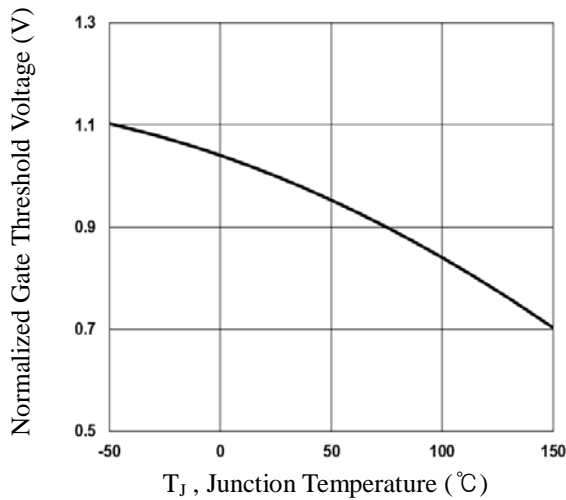

Fig.3 Normalized  $V_{th}$  vs.  $T_J$

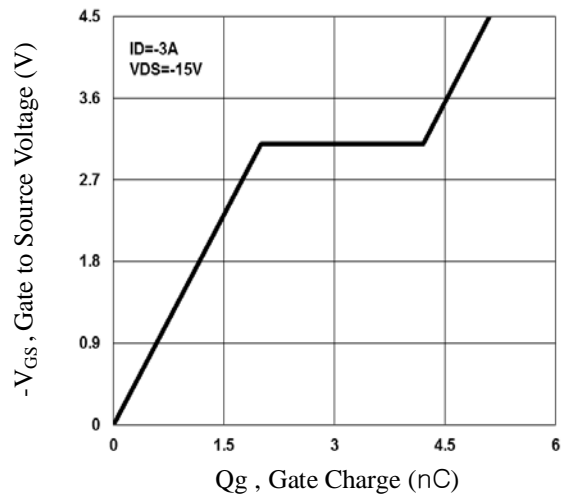

Fig.4 Gate Charge Waveform

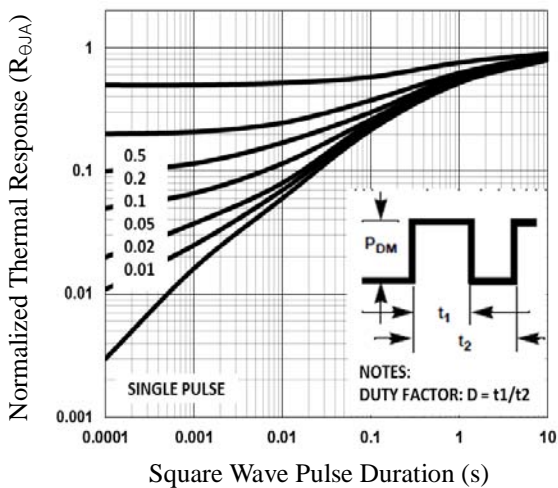

Fig.5 Normalized Transient Impedance

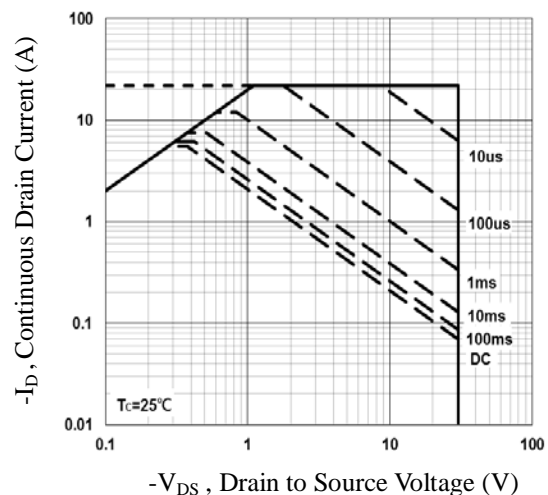

Fig.6 Maximum Safe Operation Area

## 30V P-Channel MOSFETs

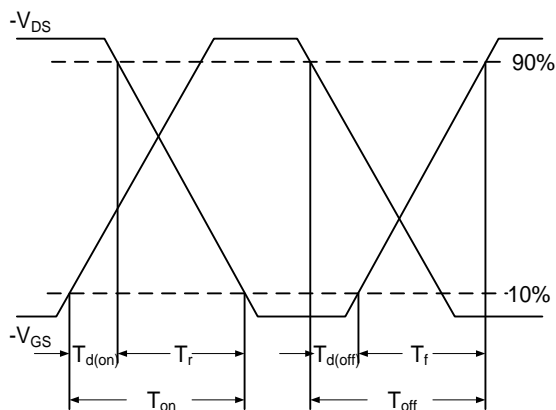

Fig.7 Switching Time Waveform

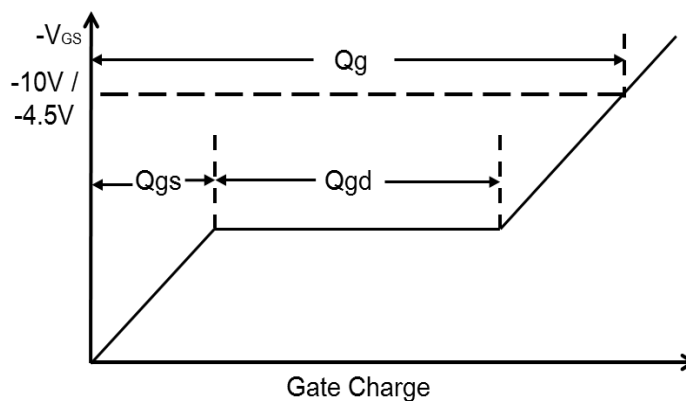
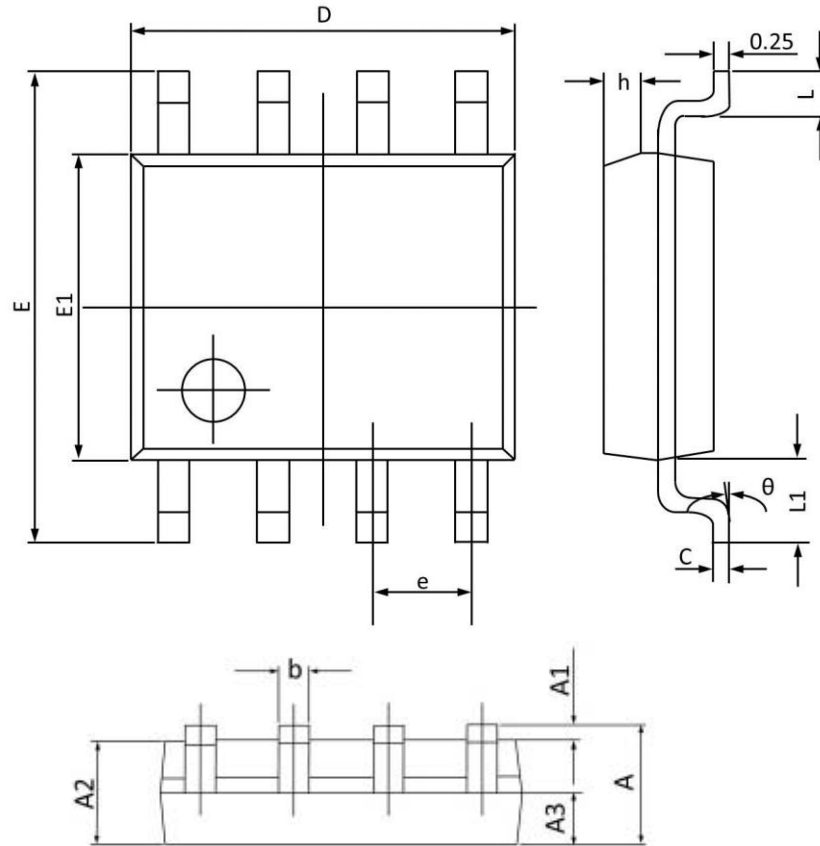

Fig.8 Gate Charge Waveform

## 30V P-Channel MOSFETs

### SOP-8 PACKAGE INFORMATION



Symbol	Dimensions In Millimeters		Dimensions In Inches	
	Min	Max	Min	Max
A	1.350	1.750	0.053	0.068
A1	0.100	0.250	0.004	0.009
A2	1.300	1.500	0.052	0.059
A3	0.600	0.700	0.024	0.027
b	0.390	0.480	0.016	0.018
c	0.210	0.260	0.009	0.010
D	4.700	5.100	0.186	0.200
E	5.800	6.200	0.229	0.244
E1	3.700	4.100	0.146	0.161
e	1.270(BSC)		0.050(BSC)	
h	0.250	0.500	0.010	0.019
L	0.500	0.800	0.019	0.031
L1	1.050(BSC)		0.041(BSC)	
θ	0°	8°	0°	8°