

40V N-Channel MOSFETs

General Description

These N-Channel enhancement mode power field effect transistors are using trench DMOS technology. This advanced technology has been especially tailored to minimize on-state resistance, provide superior switching performance, and withstand high energy pulse in the avalanche and commutation mode. These devices are well suited for high efficiency fast switching applications.

BVDSS	RDSON	ID
40V	2.2mΩ	140A

Features

- 40V, 140A, $R_{DS(ON)} = 2.2m\Omega @ V_{GS} = 10V$
- Improved dv/dt capability
- Fast switching
- Green Device Available

PPAK5X6 Pin Configuration

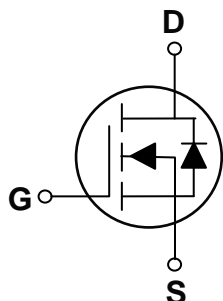

Applications

- PowerTools
- Load Switch
- LED applications
- Motor Drive Applications

Absolute Maximum Ratings ($T_c=25^\circ\text{C}$ unless otherwise noted)

Symbol	Parameter	Rating	Units
V_{DS}	Drain-Source Voltage	40	V
V_{GS}	Gate-Source Voltage	± 20	V
I_D	Drain Current – Continuous ($T_c=25^\circ\text{C}$) (Chip Limitation)	140	A
	Drain Current – Continuous ($T_c=100^\circ\text{C}$) (Chip Limitation)	88	A
I_{DM}	Drain Current – Pulsed ¹	560	A
EAS	Single Pulse Avalanche Energy ²	360	mJ
IAS	Single Pulse Avalanche Current ²	85	A
P_D	Power Dissipation ($T_c=25^\circ\text{C}$)	142	W
	Power Dissipation – Derate above 25°C	1.14	W/ $^\circ\text{C}$
T_{STG}	Storage Temperature Range	-50 to 150	$^\circ\text{C}$
T_J	Operating Junction Temperature Range	-50 to 150	$^\circ\text{C}$

Thermal Characteristics

Symbol	Parameter	Typ.	Max.	Unit
$R_{\theta JA}$	Thermal Resistance Junction to ambient	---	62	$^\circ\text{C}/\text{W}$
$R_{\theta JC}$	Thermal Resistance Junction to Case	---	0.88	$^\circ\text{C}/\text{W}$



FTK4902DFN56

40V N-Channel MOSFETs

Electrical Characteristics ($T_J=25^\circ\text{C}$, unless otherwise noted)

Off Characteristics

Symbol	Parameter	Conditions	Min.	Typ.	Max.	Unit
BV_{DSS}	Drain-Source Breakdown Voltage	$V_{GS}=0V, I_D=250\mu A$	40	---	---	V
I_{DSS}	Drain-Source Leakage Current	$V_{DS}=40V, V_{GS}=0V, T_J=25^\circ\text{C}$	---	---	1	μA
		$V_{DS}=32V, V_{GS}=0V, T_J=125^\circ\text{C}$	---	---	10	μA
I_{GSS}	Gate-Source Leakage Current	$V_{GS}=\pm 20V, V_{DS}=0V$	---	---	± 100	nA

On Characteristics

$R_{DS(ON)}$	Static Drain-Source On-Resistance	$V_{GS}=10V, I_D=30A$	---	1.7	2.2	m Ω
		$V_{GS}=4.5V, I_D=20A$	---	2.1	3	m Ω
$V_{GS(th)}$	Gate Threshold Voltage	$V_{GS}=V_{DS}, I_D=250\mu A$	1	1.6	2.5	V
g_{fs}	Forward Transconductance	$V_{DS}=10V, I_D=10A$	---	45	---	S

Dynamic and switching Characteristics

Q_g	Total Gate Charge ^{3,4}	$V_{DS}=20V, V_{GS}=4.5V, I_D=10A$	---	70	140	nC
Q_{gs}	Gate-Source Charge ^{3,4}		---	15	32	
Q_{gd}	Gate-Drain Charge ^{3,4}		---	40	80	
$T_{d(on)}$	Turn-On Delay Time ^{3,4}	$V_{DD}=20V, V_{GS}=10V, R_G=10\Omega, I_D=10A$	---	24.6	48	ns
T_r	Rise Time ^{3,4}		---	62.8	120	
$T_{d(off)}$	Turn-Off Delay Time ^{3,4}		---	224	440	
T_f	Fall Time ^{3,4}		---	162	320	
C_{iss}	Input Capacitance	$V_{DS}=25V, V_{GS}=0V, F=1\text{MHz}$	---	8000	12000	pF
C_{oss}	Output Capacitance		---	550	1000	
C_{riss}	Reverse Transfer Capacitance		---	420	800	
R_g	Gate resistance	$V_{GS}=0V, V_{DS}=0V, F=1\text{MHz}$	---	1.2	2.4	Ω

Drain-Source Diode Characteristics and Maximum Ratings

Symbol	Parameter	Conditions	Min.	Typ.	Max.	Unit
I_S	Continuous Source Current	$V_G=V_D=0V, \text{Force Current}$	---	---	140	A
I_{SM}	Pulsed Source Current		---	---	280	A
V_{SD}	Diode Forward Voltage	$V_{GS}=0V, I_S=1A, T_J=25^\circ\text{C}$	---	---	1	V
t_{rr}	Reverse Recovery Time	$V_{GS}=0V, I_S=20A, di/dt=100A/\mu s$	---	32	---	ns
Q_{rr}	Reverse Recovery Charge	$T_J=25^\circ\text{C}$	---	19	---	nC

Note :

1. Repetitive Rating : Pulsed width limited by maximum junction temperature.
2. $V_{DD}=25V, V_{GS}=10V, L=0.1\text{mH}, I_{AS}=85A, \text{Starting } T_J=25^\circ\text{C}$
3. The data tested by pulsed , pulse width $\leq 300\mu s$, duty cycle $\leq 2\%$.
4. Essentially independent of operating temperature.

40V N-Channel MOSFETs

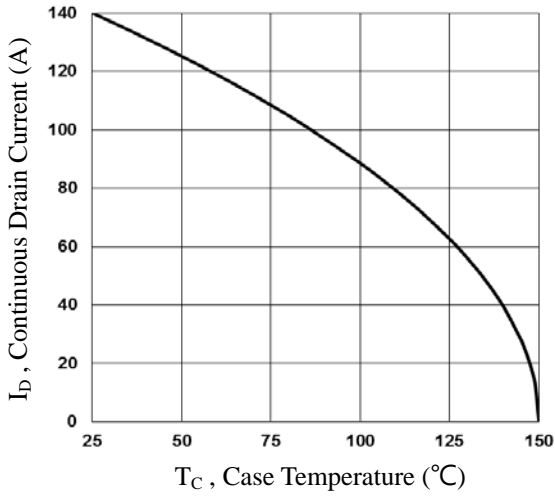

Fig.1 Continuous Drain Current vs. T_C

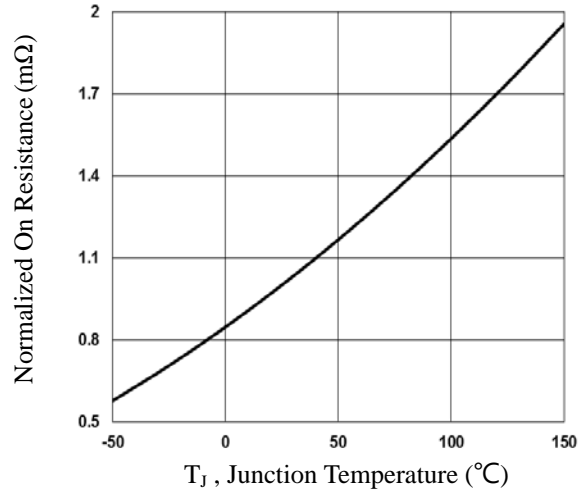

Fig.2 Normalized RDSON vs. T_J

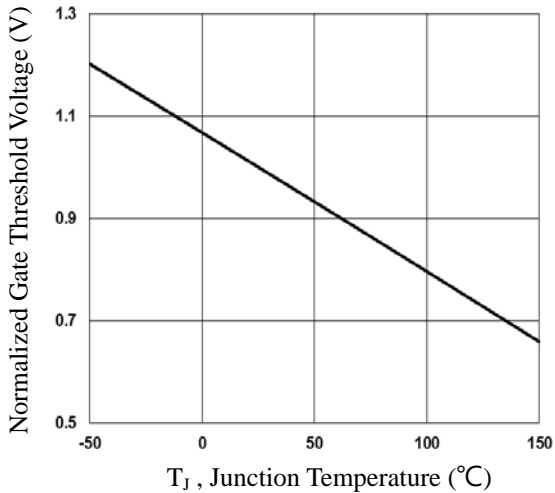

Fig.3 Normalized V_{th} vs. T_J

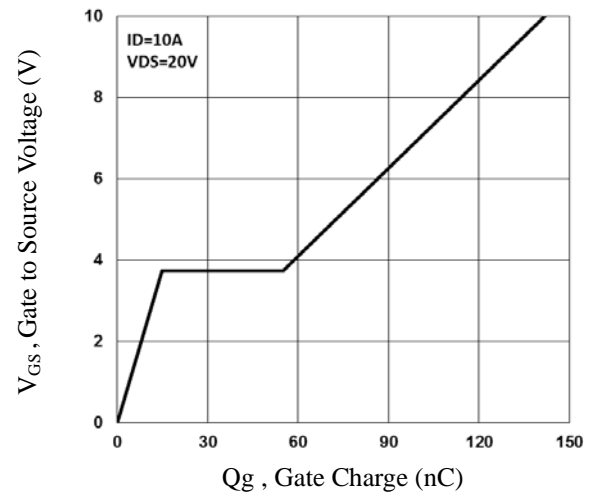

Fig.4 Gate Charge Characteristics

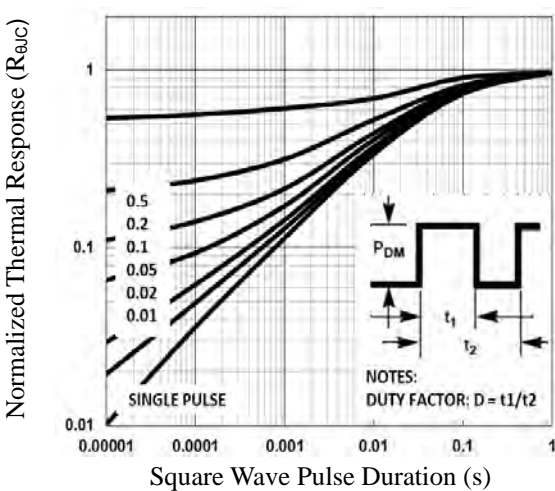

Fig.5 Normalized Transient Impedance

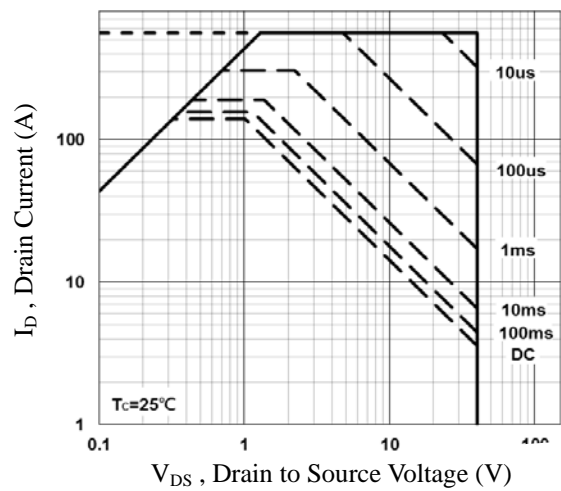

Fig.6 Maximum Safe Operation Area

40V N-Channel MOSFETs

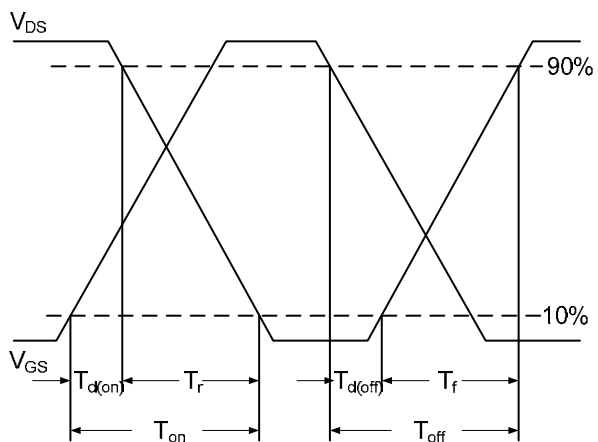

Fig.7 Switching Time Waveform

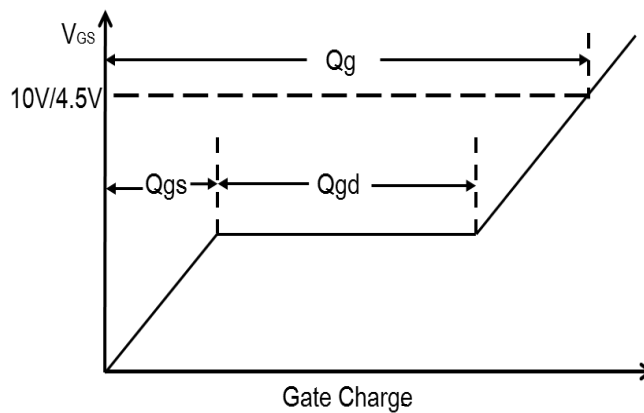
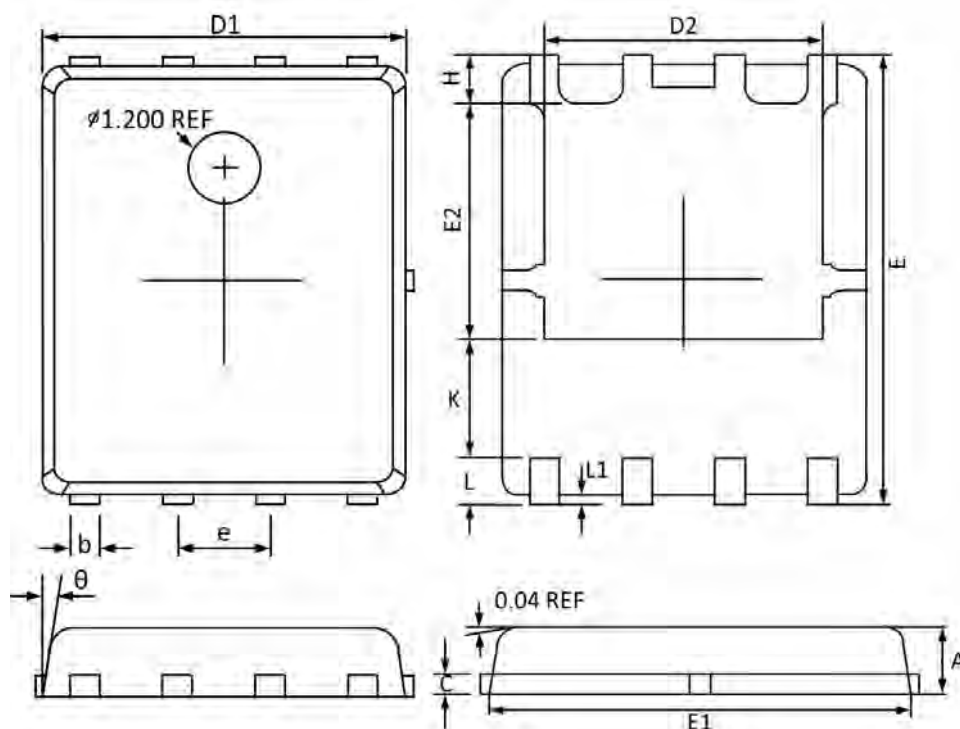

Fig.8 Gate Charge Waveform

40V N-Channel MOSFETs

PPAK5x6 PACKAGE INFORMATION



Symbol	Dimensions In Millimeters		Dimensions In Inches	
	MAX	MIN	MAX	MIN
A	1.100	0.800	0.043	0.031
b	0.510	0.330	0.020	0.013
C	0.300	0.200	0.012	0.008
D1	5.100	4.800	0.201	0.189
D2	4.100	3.610	0.161	0.142
E	6.200	5.900	0.244	0.232
E1	5.900	5.700	0.232	0.224
E2	3.780	3.350	0.149	0.132
e	1.27BSC		0.05BSC	
H	0.700	0.410	0.028	0.016
K	1.500	1.100	0.059	0.043
L	0.710	0.510	0.028	0.020
L1	0.200	0.060	0.008	0.002
theta	12°	0°	12°	0°