

N Channel +P Channel MOSFET

$V_{(BR)DSS}$	$R_{DS(on)MAX}$	I_D
40V	19mΩ@10V	8A
	29mΩ@4.5V	
-40V	35mΩ@-10V	-7A
	45mΩ@-4.5V	

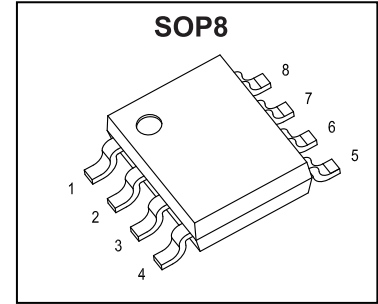

FEATURE

- Surface Mount Package
- Super High Density Cell Design for Extremely Low $R_{DS(ON)}$

APPLICATION

- CCFL Inverter

MARKING



Q4614= Device code
YY= Code
Solid dot = Pin1 indicator
Solid dot = Green molding compound device, if none, the normal device.

Equivalent Circuit

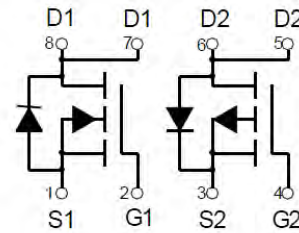

ABSOLUTE MAXIMUM RATINGS ($T_a=25^\circ\text{C}$ unless otherwise noted)

Parameter	Symbol	Value	Unit
N-MOSFET			
Drain-Source Voltage	V_{DS}	40	V
Gate-Source Voltage	V_{GS}	± 20	V
Continuous Drain Current (note 1)	I_D	8	A
Pulsed Drain Current ($t_p=10\mu\text{s}$)	I_{DM}	32	A
Continuous Source-Drain Diode Current	I_S	8	A
P-MOSFET			
Drain-Source Voltage	V_{DS}	-40	V
Gate-Source Voltage	V_{GS}	± 20	V
Continuous Drain Current (note 1)	I_D	-7	A
Pulsed Drain Current ($t_p=10\mu\text{s}$)	I_{DM}	-28	A
Continuous Source-Drain Diode Current	I_S	-7	A
Temperature and Thermal Resistance			
Power Dissipation	P_D	2	W
Thermal Resistance from Junction to Ambient (note 1)	$R_{\theta JA}$	62.5	$^\circ\text{C/W}$
Junction Temperature	T_J	150	$^\circ\text{C}$
Storage Temperature	T_{STG}	-55~+150	$^\circ\text{C}$
Lead Temperature for Soldering Purposes(1/8" from case for 10 s)	T_L	260	$^\circ\text{C}$



FTK4614

N-ch MOSFET ELECTRICAL CHARACTERISTICS(T_a=25°C unless otherwise noted)

Parameter	Symbol	Test Condition	Min	Typ	Max	Unit
STATIC CHARACTERISTICS						
Drain-source breakdown voltage	V _{(BR)DSS}	V _{GS} = 0V, I _D =250μA	40			V
Zero gate voltage drain current	I _{DSS}	V _{DS} =40V, V _{GS} = 0V			1	μA
Gate-body leakage current	I _{GSS}	V _{GS} =±20V, V _{DS} = 0V			±100	nA
Gate threshold voltage (note 2)	V _{GS(th)}	V _{DS} =V _{GS} , I _D =250μA	1	1.5	2	V
Drain-source on-resistance(note 2)	R _{DSON}	V _{GS} =10V, I _D =8A		16	19	mΩ
		V _{GS} =4.5V, I _D =4A		24	29	mΩ
Forward tranconductance(note 2)	g _{FS}	V _{DS} =5V, I _D =8A		10		S
Diode forward voltage	V _{SD}	I _S =8A, V _{GS} = 0V			1.2	V
DYNAMIC CHARACTERISTICS (note 4)						
Input Capacitance	C _{iss}	V _{DS} =20V, V _{GS} =0V, f =1MHz		415		pF
Output Capacitance	C _{oss}			112		pF
Reverse Transfer Capacitance	C _{rss}			11		pF
SWITCHING CHARACTERISTICS (note 3,4)						
Turn-on delay time	t _{d(on)}	V _{GEN} =10V, V _{DD} =20V, R _G =3Ω, R _L =2.5Ω		4		ns
Turn-on rise time	t _r			3		ns
Turn-off delay time	t _{d(off)}			15		ns
Turn-off fall time	t _f			2		ns
Total Gate Charge	Q _g	V _{DS} =20V, I _D =8A, V _{GS} =10V		12		nC
Gate-Source Charge	Q _{gs}			3.2		nC
Gate-Drain Charge	Q _{gd}			3.1		nC

P-ch MOSFET ELECTRICAL CHARACTERISTICS(T_a=25°C unless otherwise noted)

Parameter	Symbol	Test Condition	Min	Typ	Max	Unit
STATIC CHARACTERISTICS						
Drain-source breakdown voltage	V _{(BR)DSS}	V _{GS} = 0V, I _D =-250μA	-40			V
Zero gate voltage drain current	I _{DSS}	V _{DS} =-40V, V _{GS} = 0V			-1	μA
Gate-body leakage current	I _{GSS}	V _{GS} =±20V, V _{DS} = 0V			±100	nA
Gate threshold voltage (note 2)	V _{GS(th)}	V _{DS} =V _{GS} , I _D =-250μA	-1	-1.5	-2	V
Drain-source on-resistance(note 2)	R _{DSON}	V _{GS} =-10V, I _D =-8A		30	35	mΩ
		V _{GS} =-4.5V, I _D =-4A		40	45	mΩ
Forward tranconductance(note 2)	g _{FS}	V _{DS} =-5V, I _D =-8A		16		S
Diode forward voltage	V _{SD}	I _S =-10A, V _{GS} = 0V			-1.2	V
DYNAMIC CHARACTERISTICS (note 4)						
Input Capacitance	C _{iss}	V _{DS} =-20V, V _{GS} =0V, f =1MHz		520		pF
Output Capacitance	C _{oss}			100		pF
Reverse Transfer Capacitance	C _{rss}			65		pF
SWITCHING CHARACTERISTICS (note 3,4)						
Turn-on delay time	t _{d(on)}	V _{GEN} =-10V, V _{DD} =-20V, R _G =6Ω, R _L =2.3Ω		7.5		ns
Turn-on rise time	t _r			5.5		ns
Turn-off delay time	t _{d(off)}			19		ns
Turn-off fall time	t _f			7		ns
Total Gate Charge	Q _g	V _{DS} =-20V, I _D =-8A, V _{GS} =-10V		13		nC
Gate-Source Charge	Q _{gs}			3.8		nC
Gate-Drain Charge	Q _{gd}			3.1		nC

Notes :

- 1.Surface mounted on FR4 board using the minimum recommended pad size.
2. Pulse Test : Pulse width=300μs, duty cycle≤2%.
3. Switching characteristics are independent of operating junction temperature.
4. Graranted by design, not subject to producing.

N-CHANNEL TYPICAL ELECTRICAL AND THERMAL CHARACTERISTICS

Output Characteristics

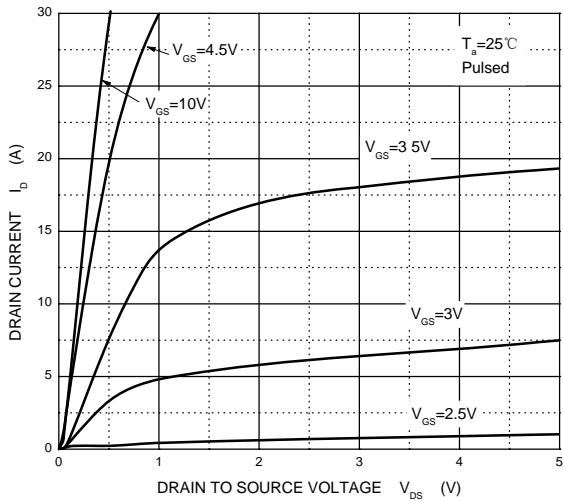

Transfer Characteristics

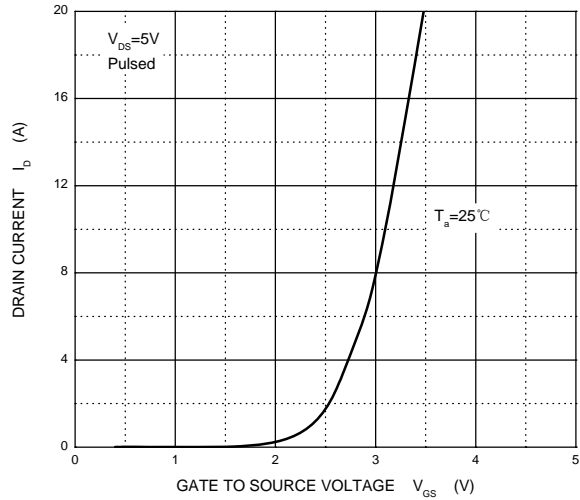

$R_{DS(ON)}$ — I_D

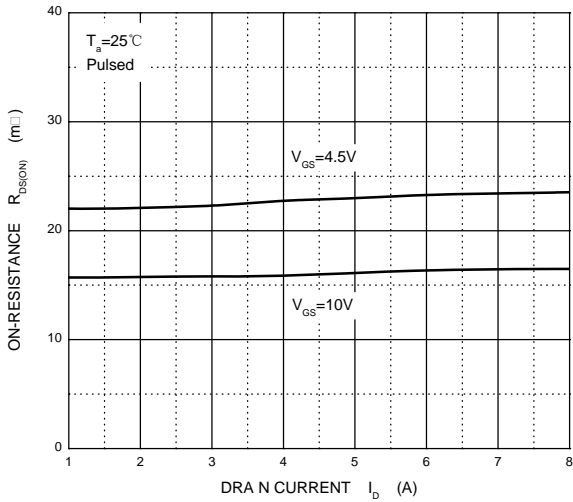

$R_{DS(ON)}$ — V_{GS}

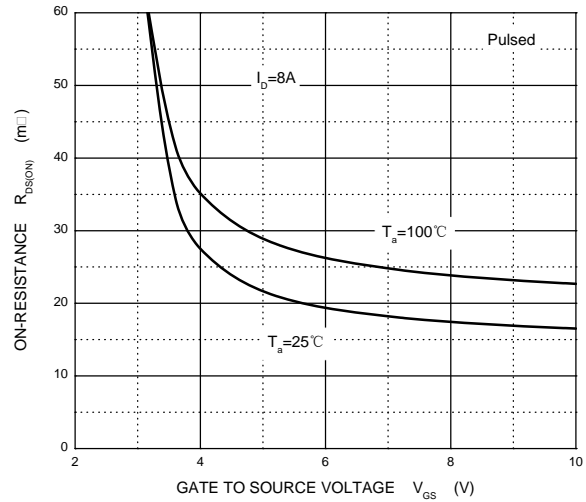

I_S — V_{SD}

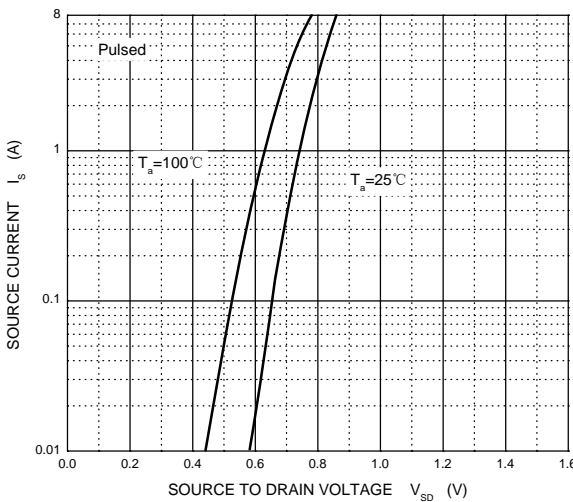

Threshold Voltage

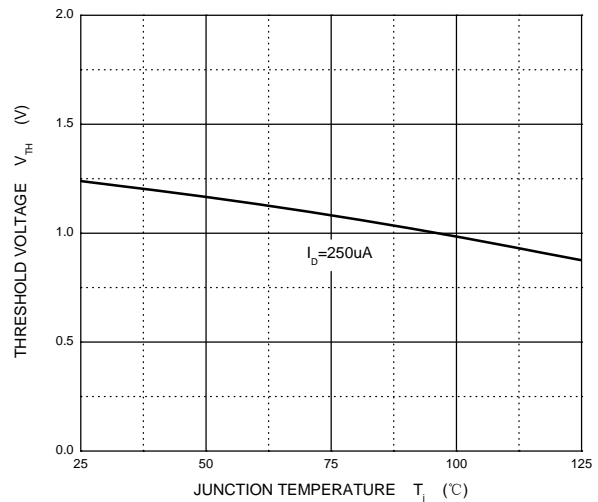

P-CHANNEL TYPICAL ELECTRICAL AND THERMAL CHARACTERISTICS

Output Characteristics

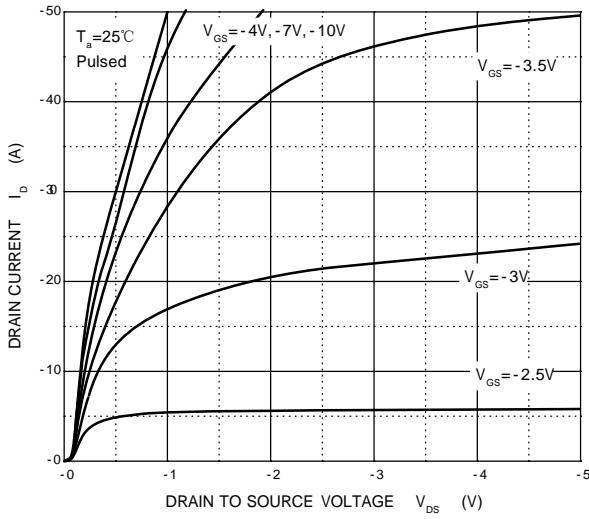

Transfer Characteristics

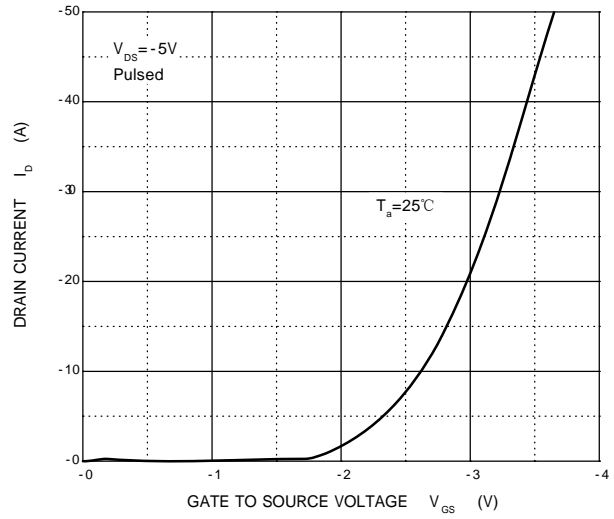

$R_{DS(ON)}$ — I_D

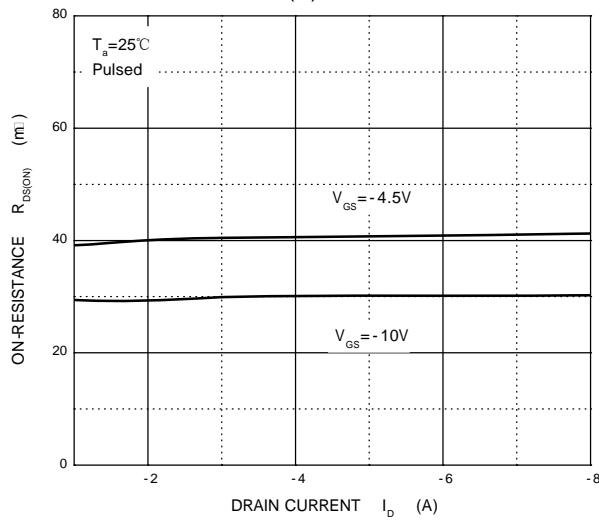

$R_{DS(ON)}$ — V_{GS}

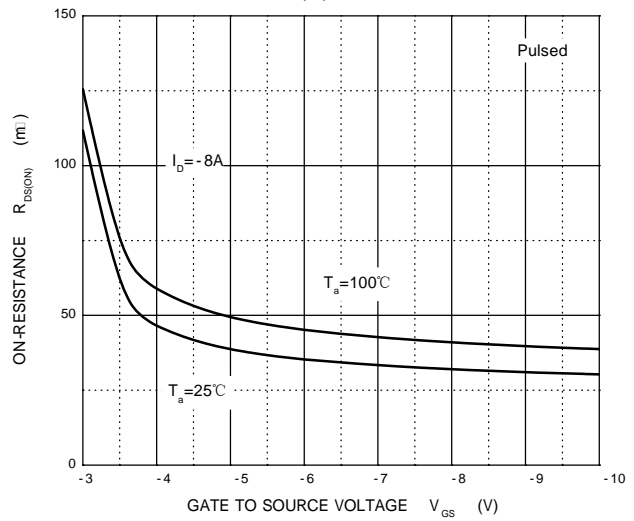

I_S — V_{SD}

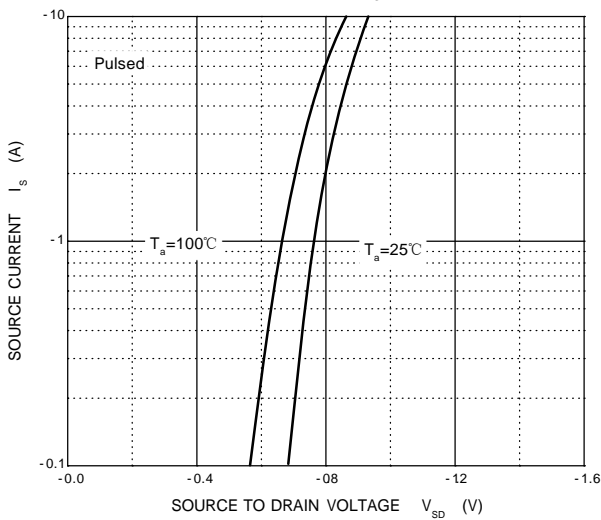

Threshold Voltage

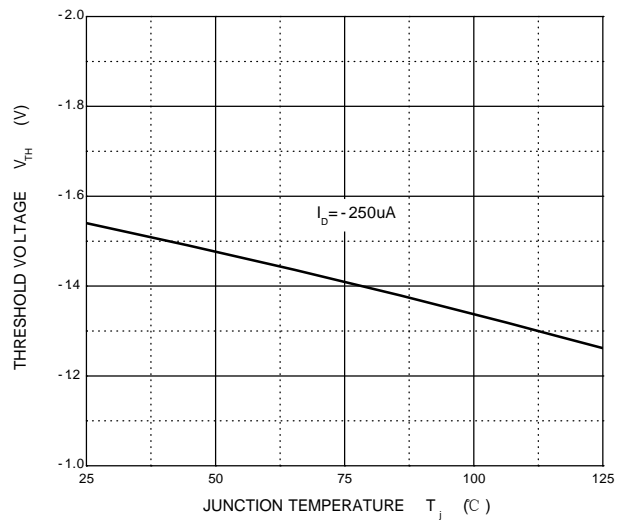

SOP8 Package Outline Dimensions

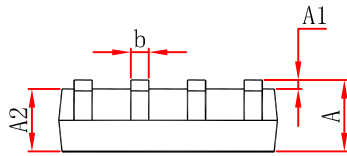
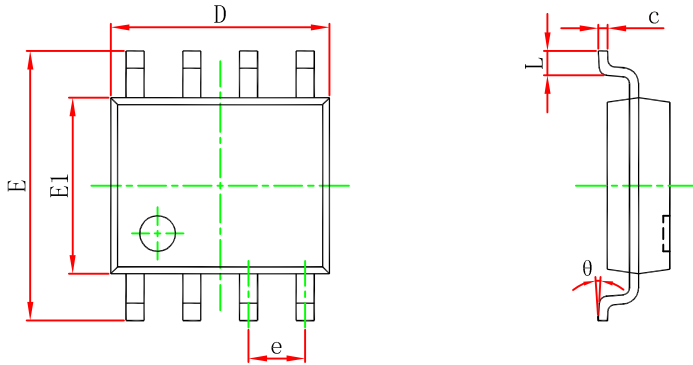

Symbol	Dimensions In Millimeters		Dimensions In Inches	
	Min	Max	Min	Max
A	1.350	1.750	0.053	0.069
A1	0.100	0.250	0.004	0.010
A2	1.350	1.550	0.053	0.061
b	0.330	0.510	0.013	0.020
c	0.170	0.250	0.007	0.010
D	4.800	5.000	0.189	0.197
e	1.270 (BSC)		0.050 (BSC)	
E	5.800	6.200	0.228	0.244
E1	3.800	4.000	0.150	0.157
L	0.400	1.270	0.016	0.050
θ	0°	8°	0°	8°

SOP8 Suggested Pad Layout

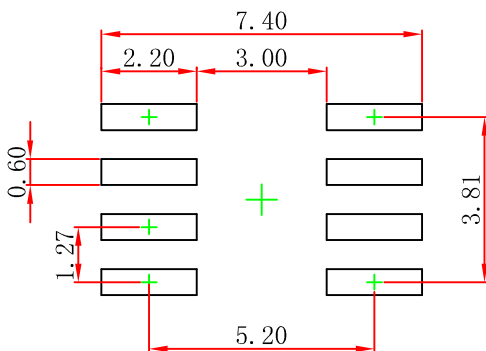

Note:
 1. Controlling dimension: in millimeters.
 2. General tolerance: $\pm 0.05\text{mm}$.
 3. The pad layout is for reference purposes only.