

## 40V P-Channel MOSFETs

### General Description

These P-Channel enhancement mode power field effect transistors are using trench DMOS technology. This advanced technology has been especially tailored to minimize on-state resistance, provide superior switching performance, and withstand high energy pulse in the avalanche and commutation mode. These devices are well suited for high efficiency fast switching applications.

BVDSS	RDSON	ID
-40V	15mΩ	-55A

### Features

- -40V,-55A,  $R_{DS(ON)} = 15m\Omega @ V_{GS} = -10V$
- Fast switching
- Green Device Available
- Suit for -4.5V Gate Drive Applications

### Applications

- MB / VGA / Vcore
- POL Applications
- Load Switch
- LED Application

### TO-220 Pin Configuration

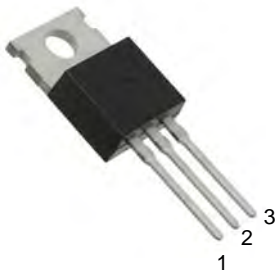

1. Gate
2. Drain
3. Source

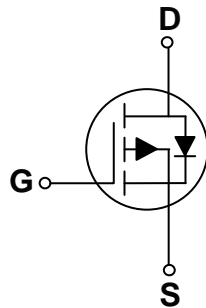

### Absolute Maximum Ratings (T<sub>C</sub>=25°C unless otherwise noted)

Symbol	Parameter	Rating	Units
V <sub>DS</sub>	Drain-Source Voltage	-40	V
V <sub>GS</sub>	Gate-Source Voltage	± 20	V
I <sub>D</sub>	Drain Current – Continuous (T <sub>C</sub> =25°C)	-55	A
	Drain Current – Continuous (T <sub>C</sub> =100°C)	-34	A
I <sub>DM</sub>	Drain Current – Pulsed <sup>1</sup>	-220	A
P <sub>D</sub>	Power Dissipation (T <sub>C</sub> =25°C)	125	W
	Power Dissipation – Derate above 25°C	1	W/°C
T <sub>STG</sub>	Storage Temperature Range	-55 to 150	°C
T <sub>J</sub>	Operating Junction Temperature Range	-55 to 150	°C

### Thermal Characteristics

Symbol	Parameter	Typ.	Max.	Unit
R <sub>θJC</sub>	Thermal Resistance Junction to Case	---	1	°C/W
R <sub>θJA</sub>	Thermal Resistance Junction to Ambient	---	62	°C/W



# FTK4903P

## 40V P-Channel MOSFETs

Electrical Characteristics ( $T_J=25^\circ\text{C}$ , unless otherwise noted)

### Off Characteristics

Symbol	Parameter	Conditions	Min.	Typ.	Max.	Unit
$BV_{DSS}$	Drain-Source Breakdown Voltage	$V_{GS}=0V, I_D=-250\mu A$	-40	---	---	V
$I_{DSS}$	Drain-Source Leakage Current	$V_{DS}=-40V, V_{GS}=0V, T_J=25^\circ\text{C}$	---	---	-1	$\mu A$
		$V_{DS}=-32V, V_{GS}=0V, T_J=125^\circ\text{C}$	---	---	-10	$\mu A$
$I_{GSS}$	Gate-Source Leakage Current	$V_{GS}=\pm 20V, V_{DS}=0V$	---	---	$\pm 100$	nA

### On Characteristics

$R_{DS(ON)}$	Static Drain-Source On-Resistance	$V_{GS}=-10V, I_D=-10A$	---	11.5	15	m $\Omega$
		$V_{GS}=-4.5V, I_D=-8A$	---	16	22	m $\Omega$
$V_{GS(th)}$	Gate Threshold Voltage	$V_{GS}=V_{DS}, I_D=-250\mu A$	-1.0	-1.6	-2.5	V
$g_{fs}$	Forward Transconductance	$V_{DS}=-10V, I_D=-10A$	---	13	---	S

### Dynamic and switching Characteristics

$Q_g$	Total Gate Charge <sup>2,3</sup>	$V_{DS}=-32V, V_{GS}=-4.5V, I_D=-10A$	---	22.2	40	nC
$Q_{gs}$	Gate-Source Charge <sup>2,3</sup>		---	8.2	16	
$Q_{gd}$	Gate-Drain Charge <sup>2,3</sup>		---	8.8	16	
$T_{d(on)}$	Turn-On Delay Time <sup>2,3</sup>	$V_{DD}=-20V, V_{GS}=-10V, R_G=6\Omega$ $I_D=-1A$	---	23	40	ns
$T_r$	Rise Time <sup>2,3</sup>		---	10	20	
$T_{d(off)}$	Turn-Off Delay Time <sup>2,3</sup>		---	135	250	
$T_f$	Fall Time <sup>2,3</sup>		---	46	90	
$C_{iss}$	Input Capacitance	$V_{DS}=-25V, V_{GS}=0V, F=1\text{MHz}$	---	2757	4000	pF
$C_{oss}$	Output Capacitance		---	240	360	
$C_{rss}$	Reverse Transfer Capacitance		---	137	200	

### Drain-Source Diode Characteristics and Maximum Ratings

Symbol	Parameter	Conditions	Min.	Typ.	Max.	Unit
$I_S$	Continuous Source Current	$V_G=V_D=0V, \text{Force Current}$	---	---	-55	A
$I_{SM}$	Pulsed Source Current		---	---	-110	A
$V_{SD}$	Diode Forward Voltage	$V_{GS}=0V, I_S=-1A, T_J=25^\circ\text{C}$	---	---	-1	V

Note :

1. Repetitive Rating : Pulsed width limited by maximum junction temperature.
2. The data tested by pulsed , pulse width  $\leq 300\mu s$  , duty cycle  $\leq 2\%$ .
3. Essentially independent of operating temperature.

## 40V P-Channel MOSFETs

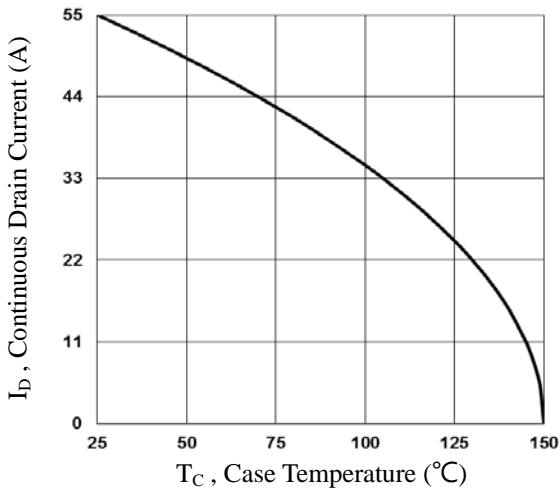

Fig.1 Continuous Drain Current vs.  $T_C$

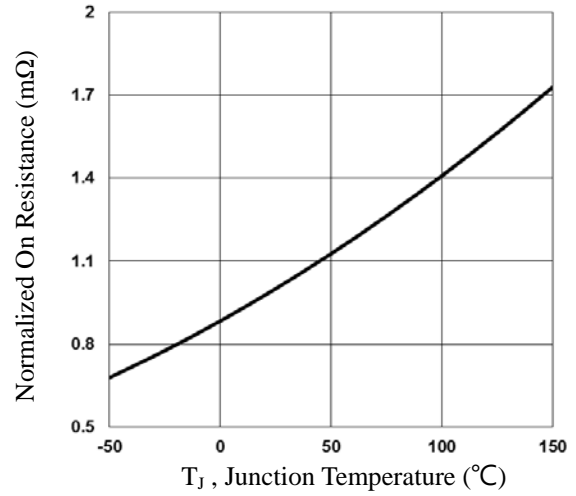

Fig.2 Normalized  $R_{DS(on)}$  vs.  $T_J$

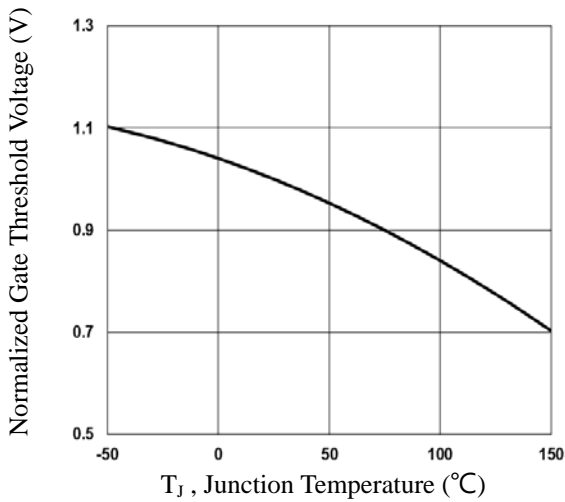

Fig.3 Normalized  $V_{th}$  vs.  $T_J$

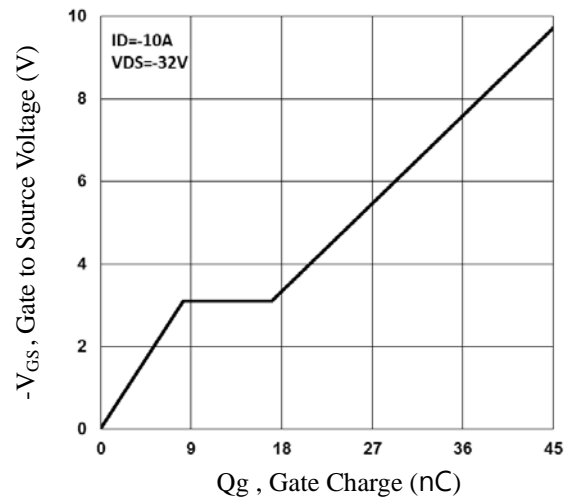

Fig.4 Gate Charge Waveform

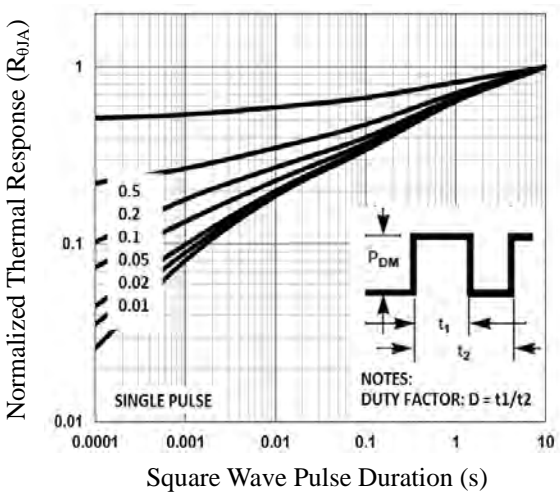

Fig.5 Normalized Transient Impedance

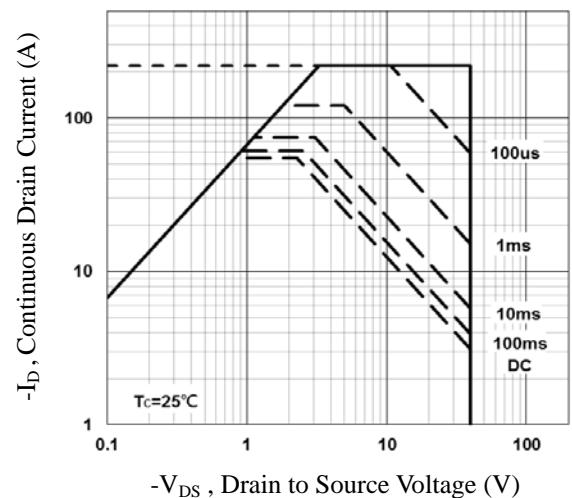

Fig.6 Maximum Safe Operation Area

## 40V P-Channel MOSFETs

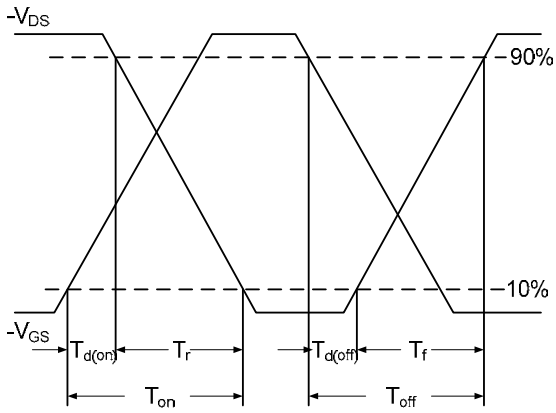

Fig.7 Switching Time Waveform

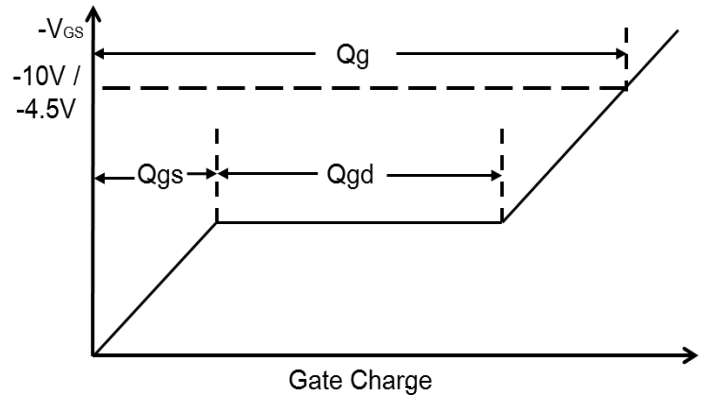
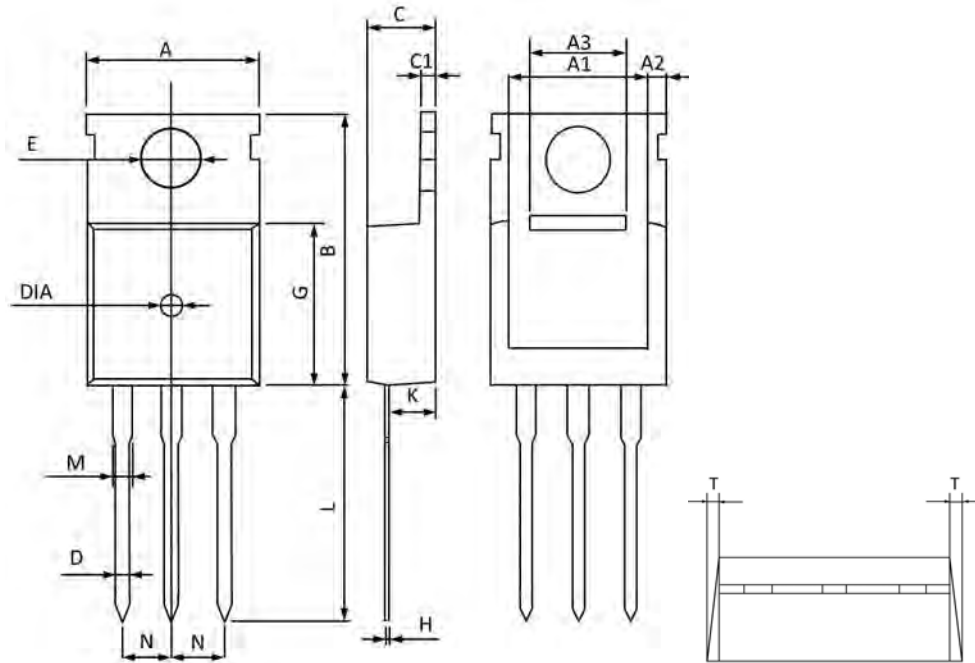

Fig.8 Gate Charge Waveform

## 40V P-Channel MOSFETs

### TO-220 PACKAGE INFORMATION



Symbol	Dimensions In Millimeters		Dimensions In Inches	
	MAX	MIN	MAX	MIN
A	10.300	9.700	0.406	0.382
A1	8.840	8.440	0.348	0.332
A2	1.250	1.050	0.049	0.041
A3	5.300	5.100	0.209	0.201
B	16.200	15.400	0.638	0.606
C	4.680	4.280	0.184	0.169
C1	1.500	1.100	0.059	0.043
D	1.000	0.600	0.039	0.024
E	3.800	3.400	0.150	0.134
G	9.300	8.700	0.366	0.343
H	0.600	0.400	0.024	0.016
K	2.700	2.100	0.106	0.083
L	13.600	12.800	0.535	0.504
M	1.500	1.100	0.059	0.043
N	2.590	2.490	0.102	0.098
T	W0.35		W0.014	
DIA	Φ1.5 TYP.	deep0.2 TYP.	Φ0.059 TYP.	deep0.008 TYP.