

P-Channel Power MOSFET

$V_{(BR)DSS}$	$R_{DS(on)}$ TYP	I_D
- 30V	9.0mΩ@-10V	-11A
	10.6mΩ@-6V	

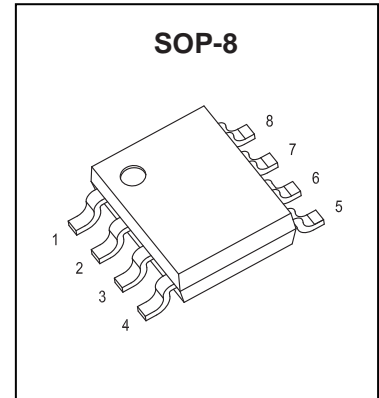

DESCRIPTION

The FTK4407S combines advanced trench MOSFET technology with a low resistance package to provide extremely low $R_{DS(ON)}$. This device is ideal for load switch and battery protection applications

APPLICATIONS

- Battery protection applications
- Load switch

MARKING

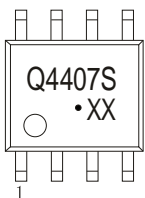

Q4407S = Device code.
Solid dot = Green molding compound device, if none, the normal device.
XX = Code.

Equivalent Circuit

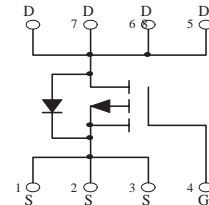

ABSOLUTE MAXIMUM RATINGS ($T_a=25^\circ\text{C}$ unless otherwise noted)

Parameter	Symbol	Value	Unit
Drain- Source Voltage	V_{DS}	- 30	V
Gate- Source Voltage	V_{GS}	± 20	V
Continuous Drain Current	I_D ^①	- 11	A
Pulsed Drain Current	I_{DM} ^②	- 42	A
Single Pulsed Avalanche Energy	E_{AS} ^③	107	mJ
Maximum Power Dissipation	P_D ^④	3	W
Thermal Resistance from Junction to Ambient	$R_{\theta JA}$ ^⑤	41.7	$^\circ\text{C}/\text{W}$
Operating Junction and Storage Temperature Range	T_J, T_{stg}	-55~+150	$^\circ\text{C}$



Electrical characteristics (T_a=25°C unless otherwise noted)

Parameter	Symbol	Test Condition	Min	Typ	Max	Unit
Off characteristics						
Drain-source breakdown voltage	V _{(BR) DSS}	V _{GS} = 0V, I _D = -250μA	-30			V
Zero gate voltage drain current	I _{DSS}	V _{DS} = -24V V _{GS} = 0V			-1	μA
		T _J = 25°C				
					-200	
Gate-body leakage current	I _{GSS}	V _{DS} = 0V, V _{GS} = ±20V			±100	nA
On characteristics ^④						
Gate-threshold voltage	V _{GS(th)}	V _{DS} = V _{GS} , I _D = -250μA	-1.0	-1.5	-2.2	V
Static drain-source on-state resistance	R _{DS(on)}	V _{GS} = -10V, I _D = -10A		9.0	15	mΩ
		V _{GS} = -6V, I _D = -8A		10.6	20	mΩ
Forward transconductance	g _{FS}	V _{DS} = -5V, I _D = -10A	25			S
Dynamic characteristics ^{④ ⑤}						
Input capacitance	C _{iSS}	V _{DS} = -15V, V _{GS} = 0V, f = 1MHz		2885	5770	pF
Output capacitance	C _{oSS}			341	682	
Reverse transfer capacitance	C _{rSS}			305	610	
Switching characteristics ^{④ ⑤}						
Total gate charge	Q _g	V _{DS} = -15V, V _{GS} = -10V, I _D = -10A		48	96	nC
Gate-source charge	Q _{gs}			12	24	
Gate-drain charge	Q _{gd}			14	28	
Turn-on delay time	t _{d(on)}	V _{DS} = -15V, V _{GS} = -10V, R _L = 1.25Ω, R _G = 3Ω		16		ns
Turn-on rise time	t _r			12		
Turn-off delay time	t _{d(off)}			45		
Turn-off fall time	t _f			21		
Drain-Source Diode Characteristics						
Drain-source diode forward voltage	V _{SD} ^①	V _{GS} = 0V, I _S = -2A			-12	V
Continuous drain-source diode forward current	I _S ^①				-11	A
Pulsed drain-source diode forward current	I _{SM} ^②				-42	A

- Notes:
- T_C=25°C Limited only by maximum temperature allowed.
 - P_W ≤ 10μs, Duty cycle ≤ 1%.
 - EAS condition: V_{DD} = -20V, V_{GS} = -10V, L = 0.5mH, R_G = 25Ω Starting T_J = 25°C.
 - Pulse Test : Pulse Width ≤ 300μs, duty cycle ≤ 2%.
 - Guaranteed by design, not subject to production.
 - The value of R_{θJA} is measured with the device mounted on 1 in 2 FR-4 board with 2oz. Copper, in a still air environment with T_a = 25°C, t ≤ 10sec.

Typical Characteristics

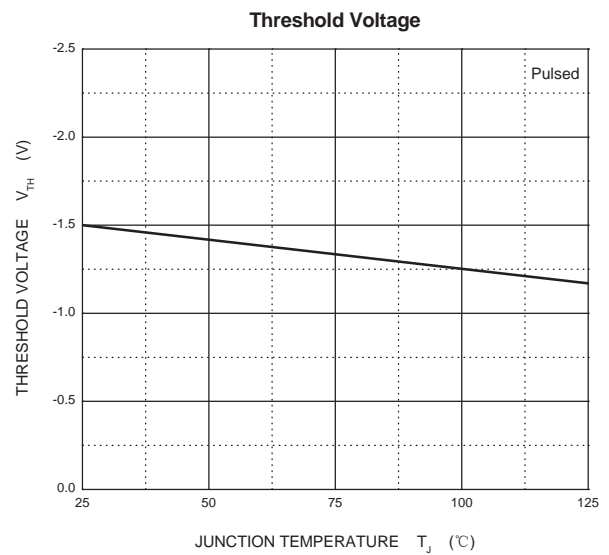
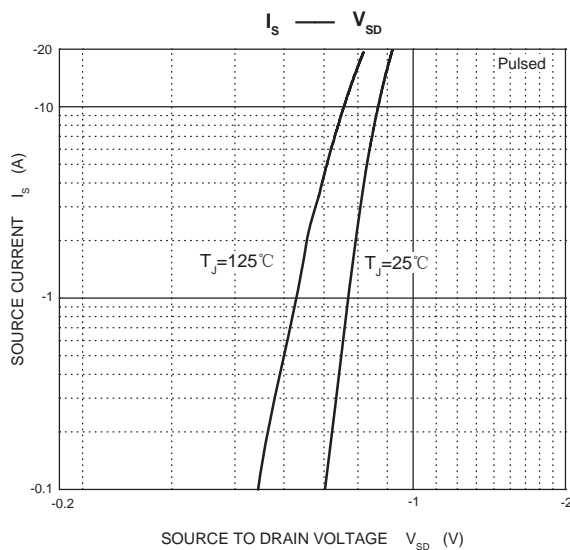
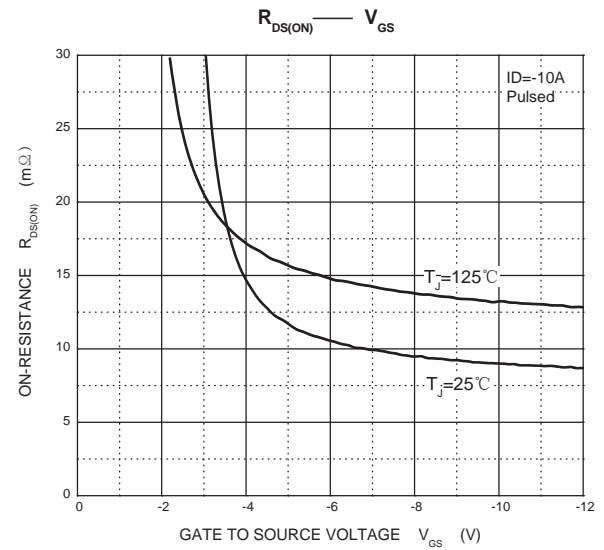
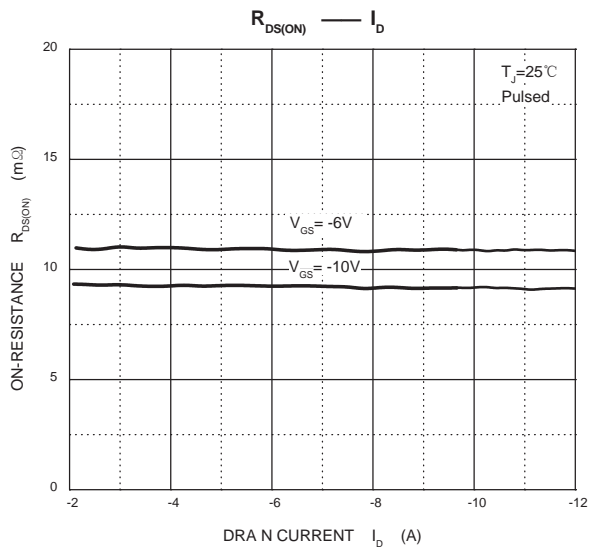
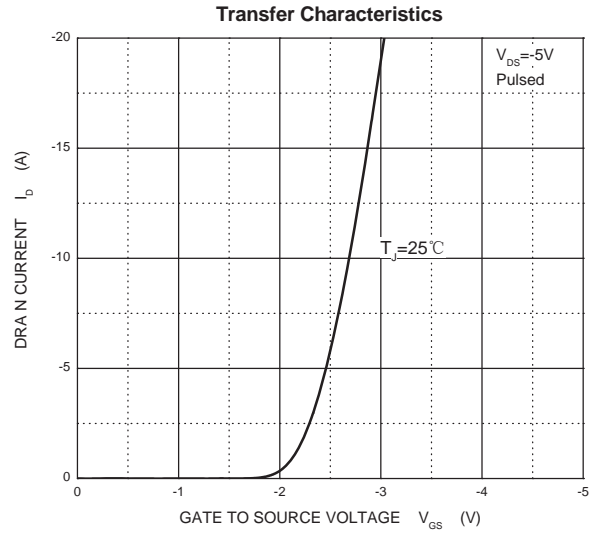
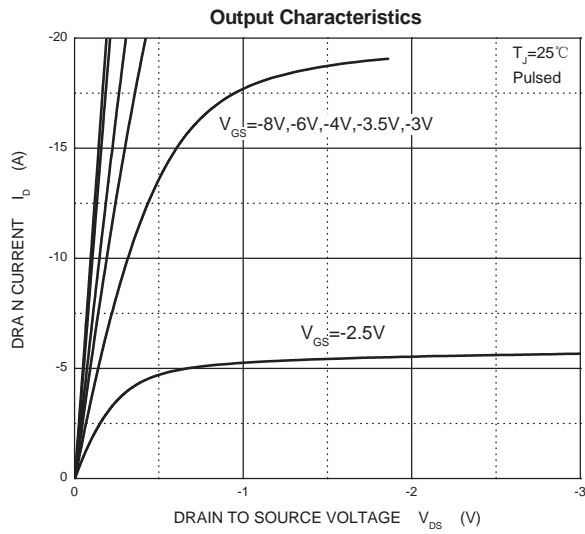

SOP8 Package Outline Dimensions

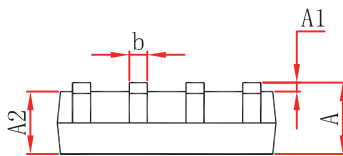
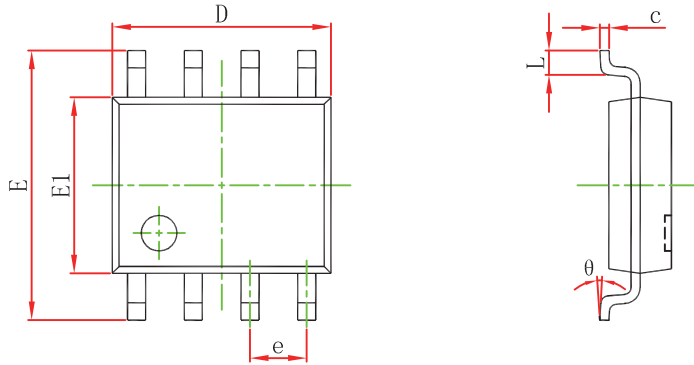

Symbol	Dimensions In Millimeters		Dimensions In Inches	
	Min	Max	Min	Max
A	1.450	1.750	0.053	0.069
A1	0.100	0.250	0.004	0.010
A2	1.350	1.550	0.053	0.061
b	0.330	0.510	0.013	0.020
c	0.170	0.250	0.007	0.010
D	4.700	5.100	0.185	0.201
e	1.270 (BSC)		0.050 (BSC)	
E	5.800	6.200	0.228	0.244
E1	3.800	4.000	0.150	0.157
L	0.400	1.270	0.016	0.050
θ	0°	8°	0°	8°

SOP8 Suggested Pad Layout

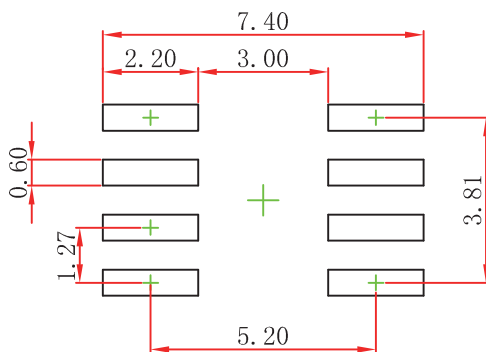

Note:

1. Controlling dimension: in millimeters.
2. General tolerance: $\pm 0.05\text{mm}$.
3. The pad layout is for reference purposes only.

SOP8 Tape and Reel

SOP8 Embossed Carrier Tape

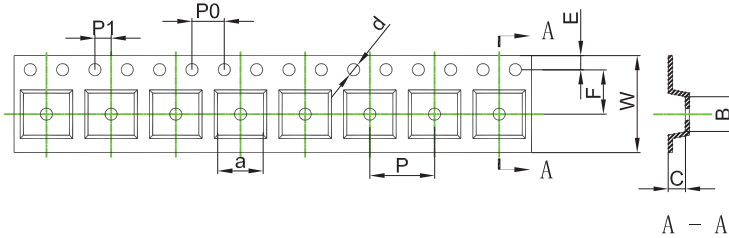

Packaging Description:

SOP8 parts are shipped in tape. The carrier tape is made from a dissipative (carbon filled) polycarbonate resin. The cover tape is a multilayer film (Heat Activated Adhesive in nature) primarily composed of polyester film, adhesive layer, sealant, and anti-static sprayed agent. These reeled parts in standard option are shipped with 2,500 units per 13" or 33cm diameter reel. The reels are clear in color and is made of polystyrene plastic (anti-static coated).

ALL DIM IN mm

Dimensions are in millimeter										
Pkg type	a	B	C	d	E	F	P0	P	P1	W
SOP8	6.40	5.40	2.10	Ø1.50	1.75	5.50	4.00	8.00	2.00	12.00

SOP8 Tape Leader and Trailer

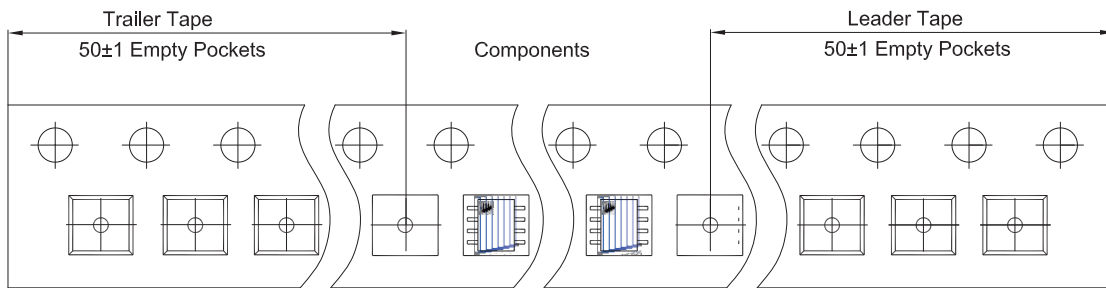

SOP8 Reel

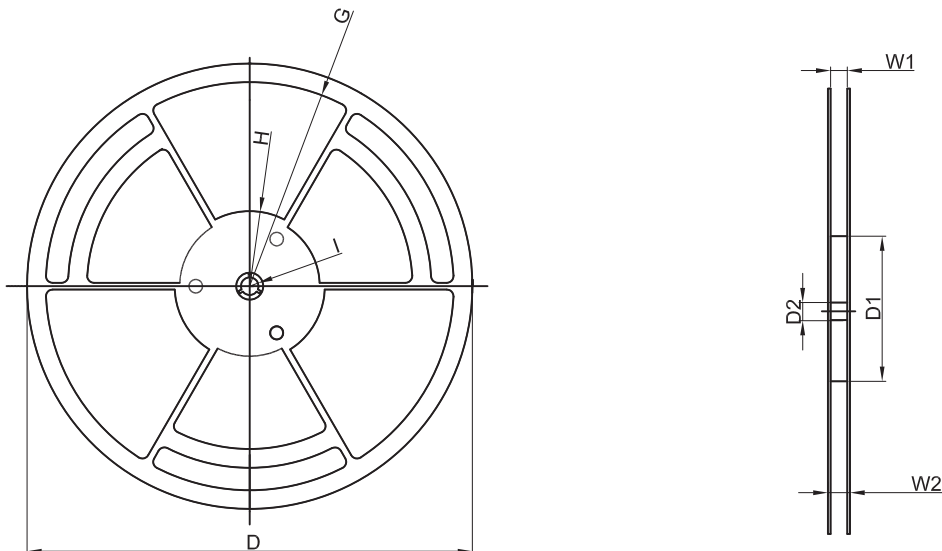

Dimensions are in millimeter								
Reel Option	D	D1	D2	G	H	I	W1	W2
13" Dia	Ø330.00	100.00	13.00	R151.00	R56.00	R6.50	12.40	17.60

REEL	Reel Size	Box	Box Size(mm)	Carton	Carton Size(mm)	G.W.(kg)
4,000 pcs	13 inch	8,000 pcs	360×360×65	64,000 pcs	565×380×390	