

## 60V N-Channel MOSFETs

### General Description

These N-Channel enhancement mode power field effect transistors are using trench DMOS technology. This advanced technology has been especially tailored to minimize on-state resistance, provide superior switching performance, and withstand high energy pulse in the avalanche and commutation mode. These devices are well suited for high efficiency fast switching applications.

BVDSS	RDSON	ID
60V	12mΩ	55A

### Features

- 60V,55A, RDS(ON) =12mΩ @VGS = 10V
- Improved dv/dt capability
- Fast switching
- 100% EAS Guaranteed
- Green Device Available

### TO-220 Pin Configuration

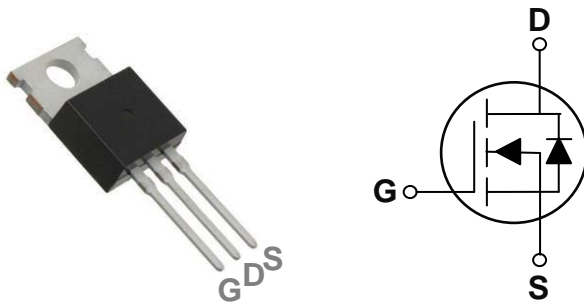

### Applications

- Motor Drive
- Power Tools
- LED Lighting

### Absolute Maximum Ratings (Tc=25°C unless otherwise noted)

Symbol	Parameter	Rating	Units
V <sub>DS</sub>	Drain-Source Voltage	60	V
V <sub>GS</sub>	Gate-Source Voltage	± 20	V
I <sub>D</sub>	Drain Current – Continuous (T <sub>C</sub> =25°C)	55	A
	Drain Current – Continuous (T <sub>C</sub> = 100°C)	35	A
I <sub>DM</sub>	Drain Current – Pulsed <sup>1</sup>	220	A
EAS	Single Pulse Avalanche Energy <sup>2</sup>	61	mJ
IAS	Single Pulse Avalanched Current <sup>2</sup>	35	A
P <sub>D</sub>	Power Dissipation (T <sub>C</sub> =25°C)	96	W
	Power Dissipation – Derate above 25°C	0.77	W/°C
T <sub>STG</sub>	Storage Temperature Range	-55 to 150	°C
T <sub>J</sub>	Operating Junction Temperature Range	-55 to 150	°C

### Thermal Characteristics

Symbol	Parameter	Typ.	Max.	Unit
R <sub>θJA</sub>	Thermal Resistance Junction to ambient	---	62	°C/W
R <sub>θJC</sub>	Thermal Resistance Junction to Case	---	1.3	°C/W



# FTK6904P

## Electrical Characteristics ( $T_J=25^\circ\text{C}$ , unless otherwise noted)

### Off Characteristics

Symbol	Parameter	Conditions	Min.	Typ.	Max.	Unit
$BV_{DSS}$	Drain-Source Breakdown Voltage	$V_{GS}=0V, I_D=250\mu A$	60	---	---	V
$\Delta BV_{DSS}/\Delta T_J$	$BV_{DSS}$ Temperature Coefficient	Reference to $25^\circ\text{C}$ , $I_D=1\text{mA}$	---	0.03	---	V/ $^\circ\text{C}$
$I_{DSS}$	Drain-Source Leakage Current	$V_{DS}=60V, V_{GS}=0V, T_J=25^\circ\text{C}$	---	---	1	$\mu A$
		$V_{DS}=48V, V_{GS}=0V, T_J=125^\circ\text{C}$	---	---	10	$\mu A$
$I_{GSS}$	Gate-Source Leakage Current	$V_{GS}=\pm 20V, V_{DS}=0V$	---	---	$\pm 100$	nA

### On Characteristics

$R_{DS(ON)}$	Static Drain-Source On-Resistance <sup>3</sup>	$V_{GS}=10V, I_D=10A$	---	10	12	m $\Omega$
		$V_{GS}=4.5V, I_D=8A$	---	12	15	m $\Omega$
$V_{GS(th)}$	Gate Threshold Voltage	$V_{GS}=V_{DS}, I_D=250\mu A$	1.2	1.6	2.5	V
$\Delta V_{GS(th)}$	$V_{GS(th)}$ Temperature Coefficient		---	-4	---	mV/ $^\circ\text{C}$
gfs	Forward Transconductance	$V_{DS}=10V, I_D=6A$	---	11.7	---	S

### Dynamic and switching Characteristics

$Q_g$	Total Gate Charge <sup>3,4</sup>	$V_{DS}=30V, V_{GS}=10V, I_D=10A$	---	39.2	59	nC
$Q_{gs}$	Gate-Source Charge <sup>3,4</sup>		---	5.9	9	
$Q_{gd}$	Gate-Drain Charge <sup>3,4</sup>		---	8.8	14	
$T_{d(on)}$	Turn-On Delay Time <sup>3,4</sup>	$V_{DD}=15V, V_{GS}=10V, R_G=6\Omega$ $I_D=1A$	---	9.6	18	ns
$T_r$	Rise Time <sup>3,4</sup>		---	28.2	54	
$T_{d(off)}$	Turn-Off Delay Time <sup>3,4</sup>		---	45.3	86	
$T_f$	Fall Time <sup>3,4</sup>		---	10.9	21	
$C_{iss}$	Input Capacitance	$V_{DS}=25V, V_{GS}=0V, F=1\text{MHz}$	---	2100	3050	pF
$C_{oss}$	Output Capacitance		---	165	240	
$C_{rss}$	Reverse Transfer Capacitance		---	80	120	
$R_g$	Gate resistance	$V_{GS}=0V, V_{DS}=0V, F=1\text{MHz}$	---	1.6	3.2	$\Omega$

### Drain-Source Diode Characteristics and Maximum Ratings

Symbol	Parameter	Conditions	Min.	Typ.	Max.	Unit
$I_S$	Continuous Source Current	$V_G=V_D=0V$ , Force Current	---	---	55	A
$I_{SM}$	Pulsed Source Current <sup>3</sup>		---	---	220	A
$V_{SD}$	Diode Forward Voltage <sup>3</sup>	$V_{GS}=0V, I_S=1A, T_J=25^\circ\text{C}$	---	---	1	V
$t_{rr}$	Reverse Recovery Time	$V_{GS}=0V, I_S=1A, di/dt=100A/\mu s$	---	---	---	ns
$Q_{rr}$	Reverse Recovery Charge	$T_J=25^\circ\text{C}$	---	---	---	nC

Note :

1. Repetitive Rating : Pulsed width limited by maximum junction temperature.
2.  $V_{DD}=25V, V_{GS}=10V, L=0.1\text{mH}, I_{AS}=35A, R_G=25\Omega$ , Starting  $T_J=25^\circ\text{C}$ .
3. The data tested by pulsed, pulse width  $\leq 300\mu s$ , duty cycle  $\leq 2\%$ .
4. Essentially independent of operating temperature.

## Typical Performance Characteristics

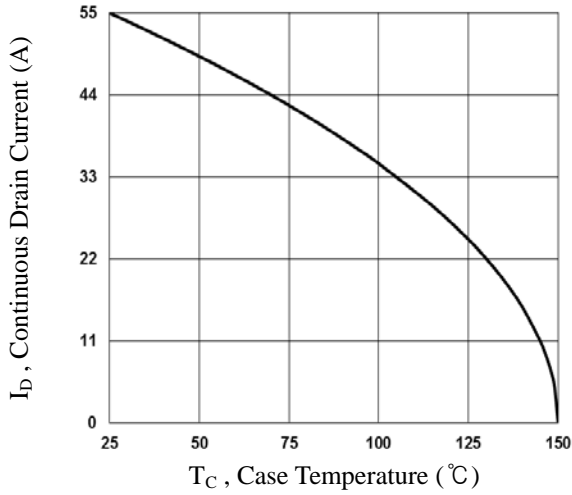

Fig.1 Continuous Drain Current vs.  $T_C$

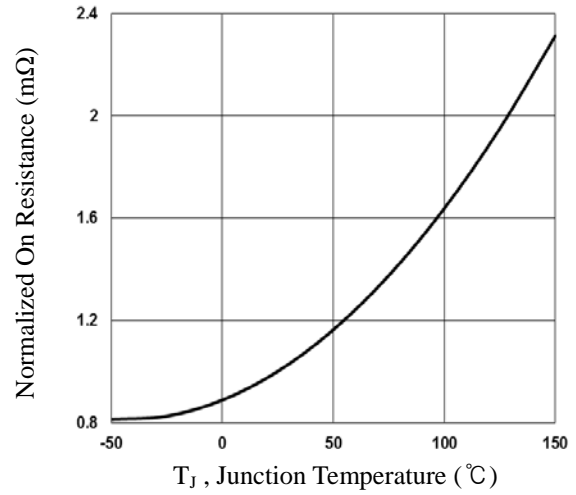

Fig.2 Normalized  $R_{DS(on)}$  vs.  $T_J$

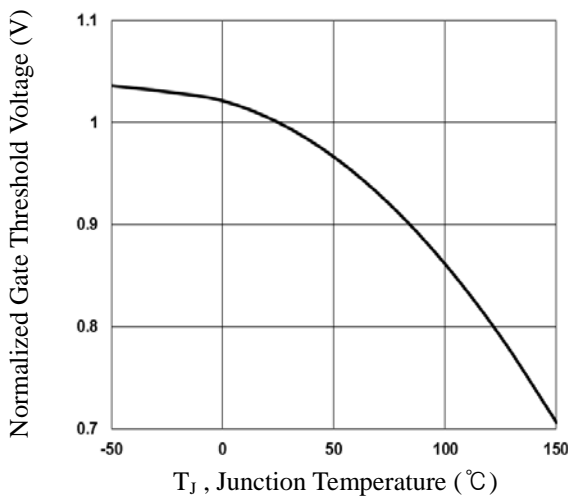

Fig.3 Normalized  $V_{th}$  vs.  $T_J$

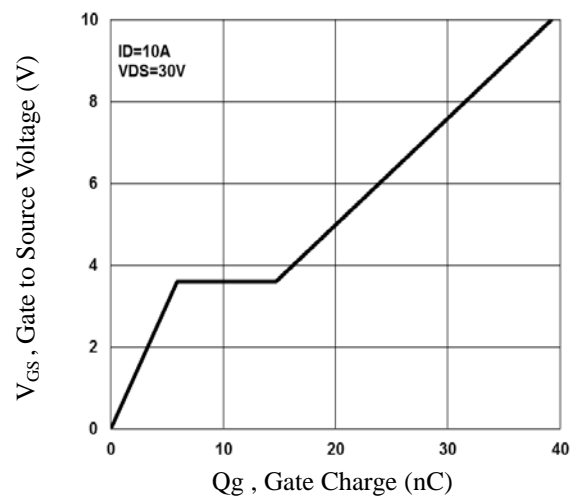

Fig.4 Gate Charge Waveform

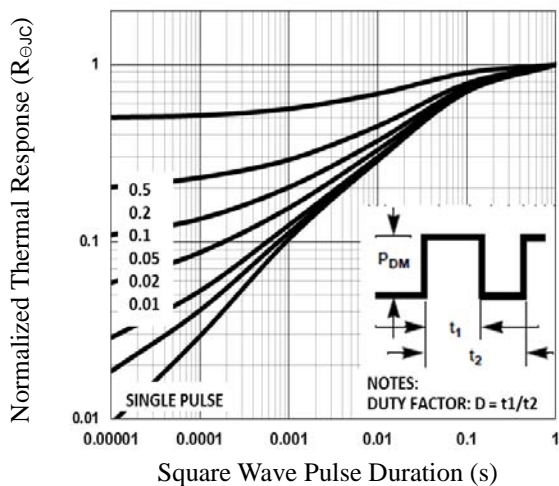

Fig.5 Normalized Transient Response

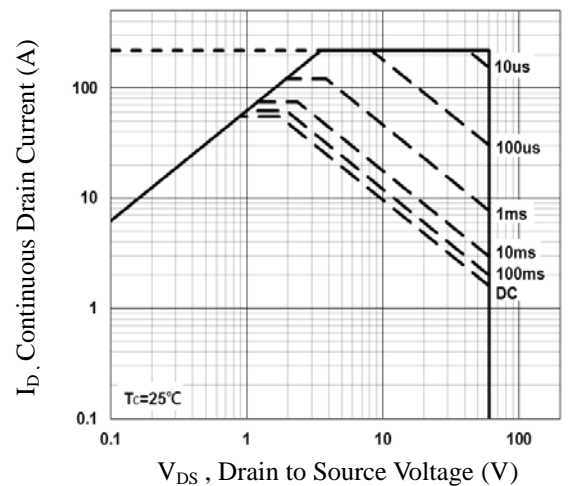

Fig.6 Maximum Safe Operation Area

## Typical Performance Characteristics(Con.)

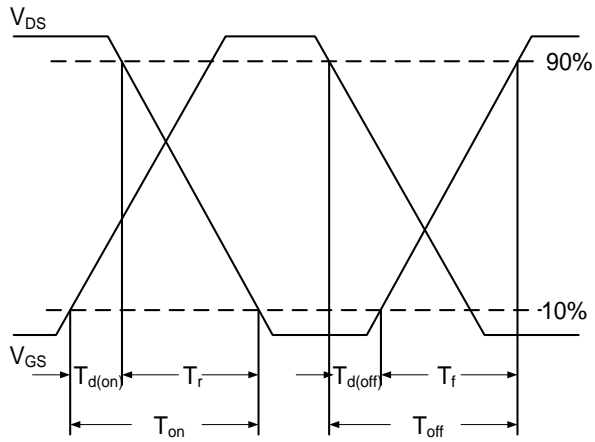

Fig.7 Switching Time Waveform

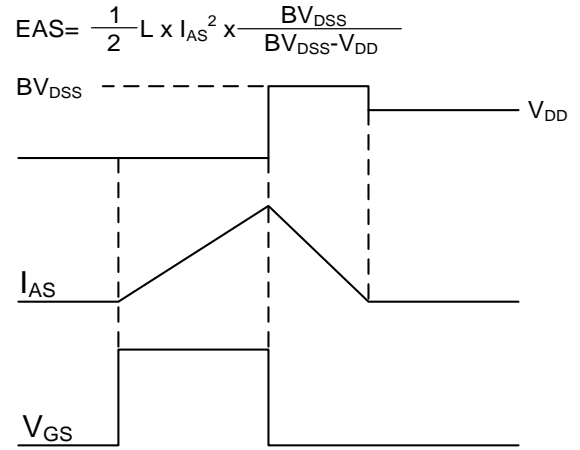
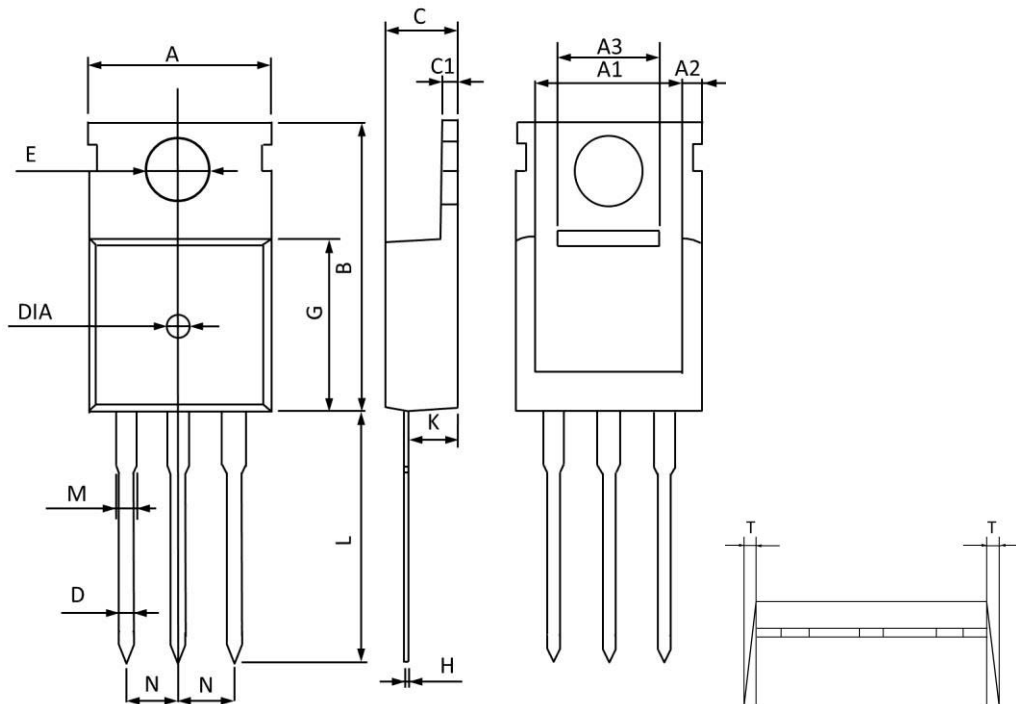

Fig.8 EAS Waveform

## TO-220 PACKAGE INFORMATION



Symbol	Dimensions In Millimeters		Dimensions In Inches	
	MAX	MIN	MAX	MIN
A	10.300	9.700	0.406	0.382
A1	8.840	8.440	0.348	0.332
A2	1.250	1.050	0.049	0.041
A3	5.300	5.100	0.209	0.201
B	16.200	15.400	0.638	0.606
C	4.680	4.280	0.184	0.169
C1	1.500	1.100	0.059	0.043
D	1.000	0.600	0.039	0.024
E	3.800	3.400	0.150	0.134
G	9.300	8.700	0.366	0.343
H	0.600	0.400	0.024	0.016
K	2.700	2.100	0.106	0.083
L	13.600	12.800	0.535	0.504
M	1.500	1.100	0.059	0.043
N	2.590	2.490	0.102	0.098
T	W0.35		W0.014	
DIA	Φ1.5 TYP.	deep0.2 TYP.	Φ0.059 TYP.	deep0.008 TYP.